



An ISO 9001  
Company

# Bharat Heavy Electricals Limited

(High Pressure Boiler Plant)

Tiruchirappalli – 620014, TAMIL NADU, INDIA

CAPITAL EQUIPMENT / MATERIALS MANAGEMENT

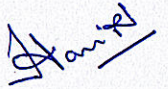
<b>ENQUIRY</b>		Phone: +91 431 257 7421/ 7297	
<b>NOTICE INVITING TENDER</b>		Email : <a href="mailto:vkaruna@bhel.in">vkaruna@bhel.in</a> , <a href="mailto:hari.r@bhel.in">hari.r@bhel.in</a>	
		Web : <a href="http://www.bhel.com">www.bhel.com</a>	
<b>TWO PART BID</b>	<b>Enquiry Number:</b>	<b>Enquiry Date:</b>	<b>Due date for submission of quotation:</b>
Tender to be submitted in two Parts	<b>2632000018</b>	<b>20.10.2020</b>	<b>20.11.2020</b>
<p>You are requested to quote the Enquiry number date and due date in all your correspondence. This is only a request for quotation and not an order. Please note that under any circumstances both delayed offer and late offers will not be considered. Hence vendors are requested to ensure that the offer is reaching physically our office before 14:00 hrs on the Date of tender opening.</p>			
<b>Item</b>	<b>Description</b>		<b>Quantity</b>
10	<b>Portable Pipe Cutting and Beveling Machine</b> as per the technical specification & commercial conditions applicable (to be downloaded from web site <a href="http://www.bhel.com">www.bhel.com</a> or <a href="https://eprocure.gov.in/epublish/app">https://eprocure.gov.in/epublish/app</a> )		1 No.
<p><b>Important points to be taken care during submission of offer</b></p> <ol style="list-style-type: none"> <li>1. Delivery terms shall be FOR BHEL BHEL- Power Plant Piping Unit, Karaikudi Road, NH 210, Thirumayam, Pudukkottai – 622507.</li> <li>2. Compliance Form MCTD/ TMM/ IND/ 07 to be filled and enclosed along with the offer failing which, the offer will not be considered for evaluation.</li> <li>3. EMD applicable for this enquiry is INR 40,000/-</li> <li>4. Delivery period required is 2 months from the date of Purchase Order.</li> <li>5. Erection and commissioning activities shall be done by the supplier, at BHEL, Trichy works.</li> <li>6. Time period required for Erection and Commissioning activities shall be 2 weeks from the date of intimation by BHEL</li> <li>7. Procurement of the item through this NIT will be as per Public Procurement (Preference to Make in India), Order 2017 dated 04.06.2020 by DPIIT (DPIIT Order No.P-45021/2/2017-PP (BE-II) dated 04.06.2020), to encourage 'Make in India ' and promote manufacturing and production of goods and services in India.</li> <li>8. All updates, amendments, corrigenda, etc., (if any), for each tender will be posted only on the above websites from time to time, as and when required, until each tender is opened. There will be no publication of such updates, amendments, corrigenda, etc., through newspapers or any other media.</li> </ol> <p>BHEL's General guidelines / instructions (refer MM/CE/GENL/001- EMD), compliance form and technical specification can be downloaded from BHEL web site <a href="http://www.bhel.com">http://www.bhel.com</a> or from <a href="https://eprocure.gov.in/epublish/app">https://eprocure.gov.in/epublish/app</a> under Enquiry reference "2632000018".</p>			
<p>Tenders should reach us before 14:00 hours on the due date Tenders will be opened at 14:30 hours on the due date Tenders would be opened in presence of the tenderers who have submitted their offers and who may like to be present</p>		<p>Yours faithfully, For BHARAT HEAVY ELECTRICALS LIMITED</p> <p> <b>R. HARI</b> Engineer MM / Capital Equipment BHEL TRICHY 620 014 Engineer / MM / Capital Equipment</p>	

Technical Specification Part-A  
**Portable Pipe cutting and bevelling machine for pipes with higher diameter**

S. No	BHEL SPECIFICATION	VENDOR COMMENTS
<b>1.0</b>	<b>QUALIFYING CRITERIA</b>	
1.1	The BIDDER / VENDOR (OEM) shall have at least <b>FIVE</b> Years of Experience in the Design, Manufacture & Supply of "Pipe cutting and bevelling machines".	
1.2	Only those vendors ( <b>OEMs</b> ), who have Manufactured, supplied and commissioned <b>at least ONE</b> pipe cutting and bevelling machines of OD clamping type with auto feed mechanism as specified under Part B, in the last ten years [as on date of this tender opening(first date)] should quote.	
1.3	Vendor has to submit at least ONE Performance Certificate from their customer, for satisfactory performance of Pipe cutting and bevelling machines supplied to them and such equipment is working satisfactorily for a minimum period of one year [as on date of this tender opening (first date)]. Performance certificate as Original Certificate or E-mail directly from the customer may be submitted. For obtaining the Performance certificate, a suggestive format is provided at the end of part-A.	
1.4	BHEL reserves the right to verify the information provided by the Vendor. In case the information provided by vendor is found to be false/ incorrect, the offer shall be rejected.	

<b>2.0</b>	<b>INFORMATION TO BE PROVIDED BY VENDOR</b>	
2.1	Vendor shall provide contact details (phone no & email id) including the address of his Agents / Service Centres in India.	
2.2	Details of Pipe cutting and bevelling machines supplied to BHEL units, if any. (Year of commissioning, Application, Type )	
2.3	Number of Pipe cutting and bevelling machines supplied and commissioned till date (to quote the equipment supplied during the last three years only)	
2.4	The BIDDER/VENDOR to furnish Reference List of Customers (max 10 customers) including Contact details (phone no & email id).	

Suggestive Format of Performance Certificate:

The performance certificate should be produced **on Customer's Letter Head.**

**PERFORMANCE CERTIFICATE**

- 1 Supplier of the machine
- 2 Make & Model of the M/C
- 3 Month & Year of Commissioning
- 4 Application for which M/C is used
- 5 Weight of the machine
- 6 Performance of the Machine  
(Strike off whichever is not applicable) Satisfactory / Not Satisfactory
- 7 After sales service  
(Strike off whichever is not applicable) Satisfactory / Not Satisfactory
- 8 Any Other remarks

Performance certificate issued date:

Signature & Seal of the Authority  
Issuing the Performance Certificate

Contact details of issuing authority  
Name & Designation:  
Office No/ Mobile no:  
Email ID:

Technical Specification Part-B  
**Portable Pipe cutting and bevelling machine for pipes with higher diameter**

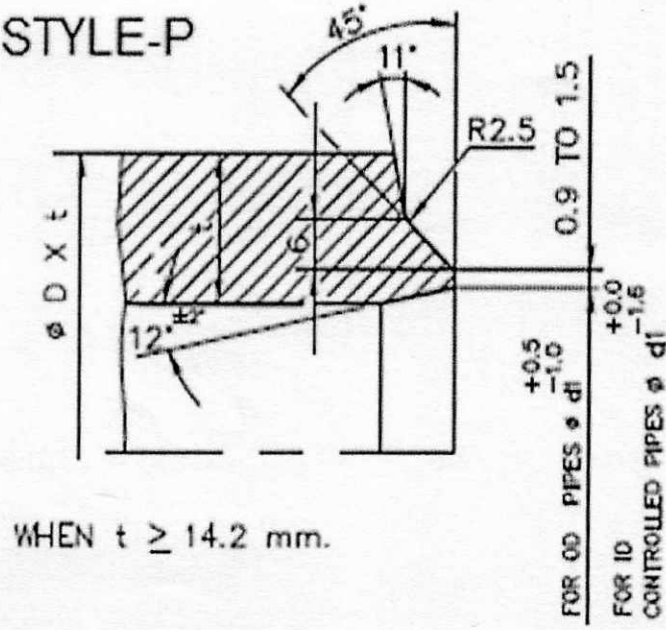
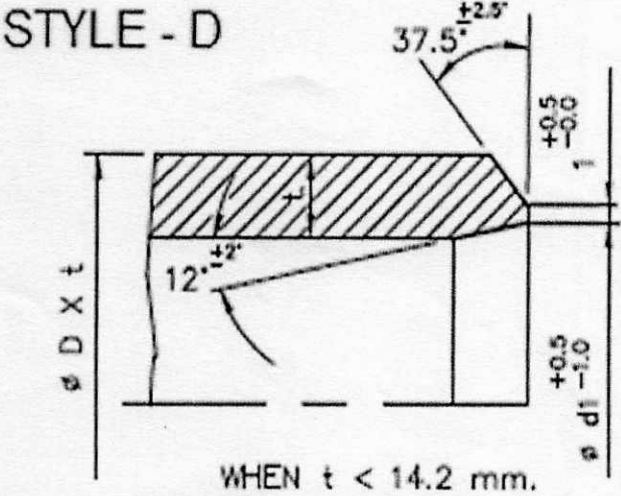
S. NO	BHEL SPECIFICATION	VENDOR COMMENTS
1.0	APPLICATION	
1.1	<p>Electrically run, portable pipe cutting and bevelling machine. The machine should be capable of performing pipe cutting and bevelling operations as per style- P &amp; D as shown in the below sketch. The length of ID machining shall be from 0 mm to 25 mm.</p> <div style="display: flex; flex-direction: column; align-items: center;"> <div style="display: flex; align-items: center; margin-bottom: 20px;"> <div style="margin-right: 20px;"> <p><b>STYLE-P</b></p>  </div> <div style="margin-left: 20px;"> <p>WHEN <math>t \geq 14.2</math> mm.</p> </div> </div> <div style="display: flex; align-items: center; margin-bottom: 20px;"> <div style="margin-right: 20px;"> <p><b>STYLE - D</b></p>  </div> <div style="margin-left: 20px;"> <p>WHEN <math>t &lt; 14.2</math> mm.</p> </div> </div> </div>	

Technical Specification Part-B  
**Portable Pipe cutting and bevelling machine for pipes with higher diameter**

S. NO	BHEL SPECIFICATION	VENDOR COMMENTS
2.0	<b>JOB DETAILS</b>	
2.1	<u>Pipe diameter</u> Machine should be capable of performing cutting and bevelling operation on pipes with outside diameter from 219mm to 406mm. The vendor to specify the actual range.	
2.2	<u>Pipe Thickness</u> Machine should be capable of performing cutting and bevelling operations on pipe with thickness from 6mm to 30mm. The vendor to specify the actual range.	
2.3	<u>Materials to be machined</u> Carbon steel, alloy steels SA335P22, SA335P91, SA335P92 & Stainless Steel.	
3.0	<b>PIPE FACING &amp; BEVELLING UNIT</b>	
3.1	<u>Brand &amp; Model</u> The vendor to specify. The unit shall be portable in nature and rigid/rugged in construction. The machine should be clamped on outside diameter of the pipe. It shall be handled by a single operator. Vendor should specify the pipe clamping jaw details for all OD range of pipes. The machine shall be suitable for fitting at any position of pipe for pipe cutting and edge preparation at ends.	
3.2	<u>Minimum straight length of pipe required for clamping</u> The vendor to specify.	
3.3	<u>Material removal rate</u> The vendor to specify.	
3.4	<u>Depth of cut and feed rate</u> Depth of cut and feed rate for the indicated edge preparation styles with the designed tool shall be as follows,  <u>Cutting:</u> 0.2mm minimum. <u>Bevelling:</u> 0.14mm minimum.	

Technical Specification Part-B  
**Portable Pipe cutting and bevelling machine for pipes with higher diameter**

S. NO	BHEL SPECIFICATION	VENDOR COMMENTS
3.5	<p><u>Weight of machine</u>  Vendor shall specify the weight of the total unit. A provision shall be given for handling with a lifting device.</p>	
3.6	<p><u>Coolant oil</u>  The vendor to specify coolant requirement for machining (Yes / No). Recommended Coolant details to be provided if needed. The machine shall have protection against coolant oil, if applicable.</p>	
3.7	<p><u>Speed of Tool in RPM</u>  The working range of tool RPM should be from 1 to 18 and it should be infinitely variable. Provision should be given to vary the speed during operation. Vendor to specify actual values.</p>	
3.8	<p><u>Feeding Mechanism</u>  Auto feed only.</p>	
3.9	<p><u>Ovality</u>  The clamping unit shall have provision for clamping pipes with Ovality of up to 3 mm</p>	
3.10	<p><u>Safety</u>  Machining operation should be safe in all aspects</p>	
3.11	<p><u>Machine Setting time</u>  Setting time of the machine on the job shall be 15 minutes' maximum.   The vendor to specify actual time.</p>	
3.12	<p><u>Working environment</u>  Machine should be able to perform under dusty environment and working temperature up to 45 degrees Celsius.</p>	

Technical Specification Part-B  
**Portable Pipe cutting and bevelling machine for pipes with higher diameter**

S. NO	BHEL SPECIFICATION	VENDOR COMMENTS
4.0	<b>CUTTING TOOL</b>	
4.1	The vendor to confirm whether the tool holders fitted with suitable cutting tools/ inserts will cover all the bevelling styles indicated in EP sketches.	
4.2	<u>Tool Material</u> The tool material shall be as follows, a. Cutting: Either heavy duty HSS or standard carbide inserts. b. Bevelling: Either heavy duty HSS or standard carbide inserts.	
4.3	<u>Tool type</u> The vendor to specify the actual type. In case of HSS, the tool type should be holder + insert type.	
4.4	<u>Additional tools</u> 25 no's of additional cutting and bevelling tools are to be supplied along with the machine by vendor.	
5.0	<b>ELECTRICAL POWER</b>	
5.1	<u>Operation Mode</u> Through electrical power. The Input power supply will be 230 V, single phase with a voltage fluctuation of +/- 10%, 50HZ with a fluctuation of +/-2%, Power supply will be provided by BHEL at a single point near the machine.	
5.2	<u>Electrical Power Rating</u> The vendor to specify.	
5.3	<u>Remote control operation</u> The remote should be wired with controller. The remote should have provision for emergency stop, Forward/ reverse rotation controls.	
5.4	<u>Electric Motor</u> The motor should be servo electric. The minimum torque while cutting and bevelling should be 7 Nm. The motor orientation should be in line with the pipe orientation.	

Technical Specification Part-B  
**Portable Pipe cutting and bevelling machine for pipes with higher diameter**

S. NO	BHEL SPECIFICATION	VENDOR COMMENTS
6.0	<b>MACHINE SPARES</b>	
6.1	<p><u>Mandatory spares and accessories</u>  Vendor to indicate the list of mandatory spares and accessories in sufficient quantity with item wise price detail. BHEL may have the privilege to include this items in full or in partial along with the main supply.</p>	
6.2	Vendor to quote the list of spares with break-up of mechanical, electrical and electronic spares used in the machine in sufficient quantity as per recommendation for 2 years of trouble free operation on three shifts continuous running basis with price details.	
6.3	One set of service tools for Operation and Maintenance of the equipment should be provided by the vendor along with the equipment.	
7.0	<b>DOCUMENTATIONS</b>	
7.1	<p>The following documents in English language should be supplied along with the machine:  <b>Hard Copies - 3 Sets</b>  <b>In CD form - 1 Set</b></p> <ol style="list-style-type: none"> <li>1. GA Drawing of the complete machining system.</li> <li>2. GA Drawing of Individual Mechanisms.</li> <li>3. Operating manuals of Machine.</li> <li>4. Maintenance manuals with all drawings of machine sub-assemblies with parts list.</li> <li>5. Electrical circuit diagrams with bill of materials.</li> <li>6. Preventive Maintenance check list for Electrical and mechanical System.</li> <li>7. Trouble shooting chart for Main and all sub systems.</li> <li>8. Catalogues, O&amp;M manuals for all bought out items used in the machine.</li> <li>9. Exploded view of all sub-assemblies with part numbers and mane details</li> <li>10. Manufacturing drawing of wear out components.</li> </ol>	
8.0	<b>DEMONSTRATION</b>	
8.1	Before price bid opening, the vendor should make demonstration of machine at our BHEL-Thirumayam. This will be required for technical evaluation of the machine. The pipe required for demonstration will be provided by BHEL.	



Technical Specification Part-B  
**Portable Pipe cutting and bevelling machine for pipes with higher diameter**

S. NO	BHEL SPECIFICATION	VENDOR COMMENTS
9.0	<b>PRE-DISPATCH INSPECTION</b>	
9.1	The equipment shall be tested for its performance at supplier's work in presence of BHEL inspector, prior to dispatch of the equipment and test certificate shall be provided. Vendor to arrange all required materials for testing.	
10.0	<b>COMMISSIONING</b>	
10.1	Vendor to prove out on the job trials during commissioning of the machine at BHEL, Thirumayam for both the maximum and minimum size jobs as offered by BHEL for each style. The tools required during commissioning is in supplier scope.	
11.0	<b>TRAINING</b>	
11.1	Vendor to give training to BHEL's Staff on Machine Operation and Maintenance (Mechanical & Electrical) during commissioning of the Machine at BHEL Thirumayam.	
12.0	<b>GUARANTEE</b>	
12.1	Performance Guarantee to be given for 12 months from the date of commissioning or 18 months from the date of dispatch whichever is earlier, for the total machine or any sub-systems, components forming part of the machine for rendering the prescribed performance / rating values.	