

सामग्री सूची संख्या INVENTORY NO.	हस्ताक्षर और दिनांक/SIGN & DATE	संदर्भित अभिकल्प संख्या REFERENCE DRG. NO.
--------------------------------------	---------------------------------	---

111-KSC3

ON DRAWING/व्यास प्लकडिआ

प्रथम कोण प्रक्षेपण/FIRST ANGLE PROJECTION

सभी विमाएं मिलीमीटर में हैं /ALL DIMENSIONS ARE IN mm.

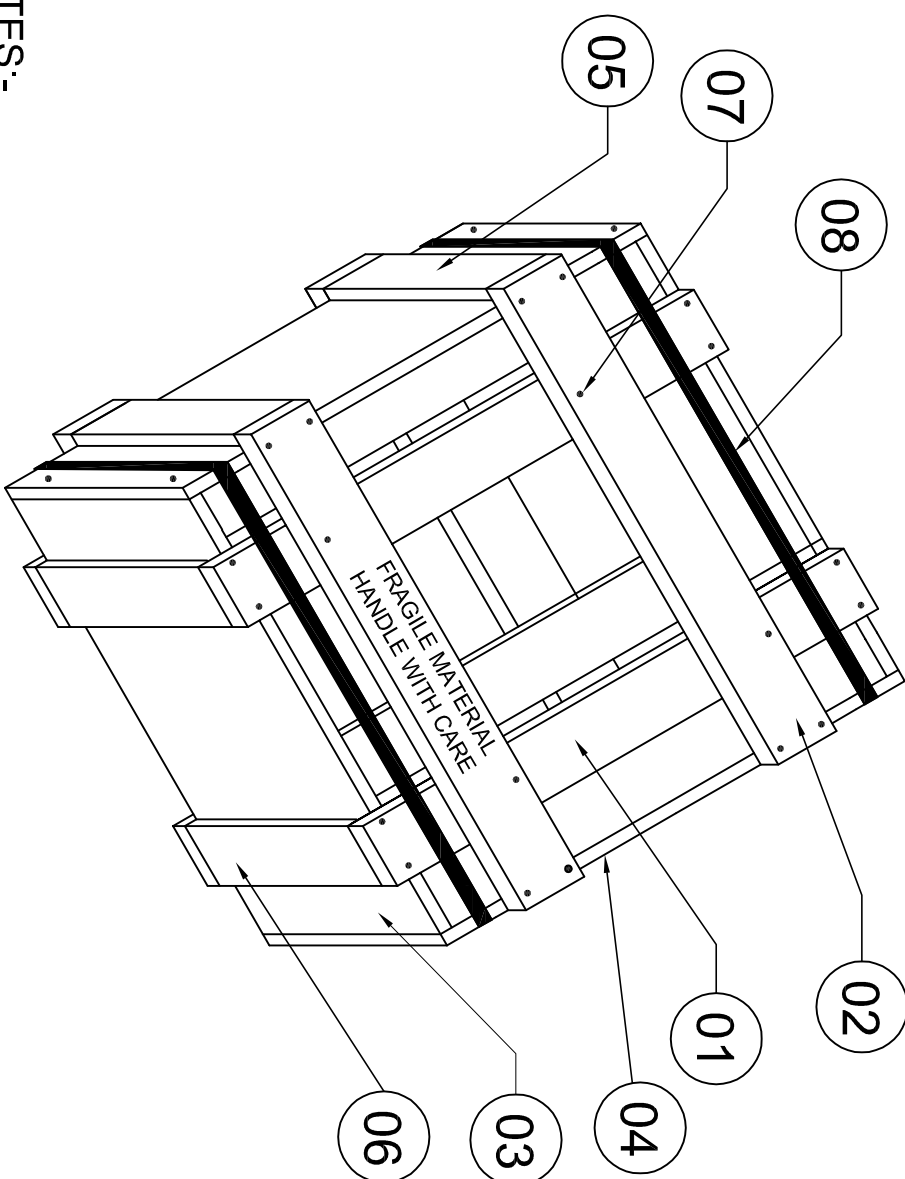
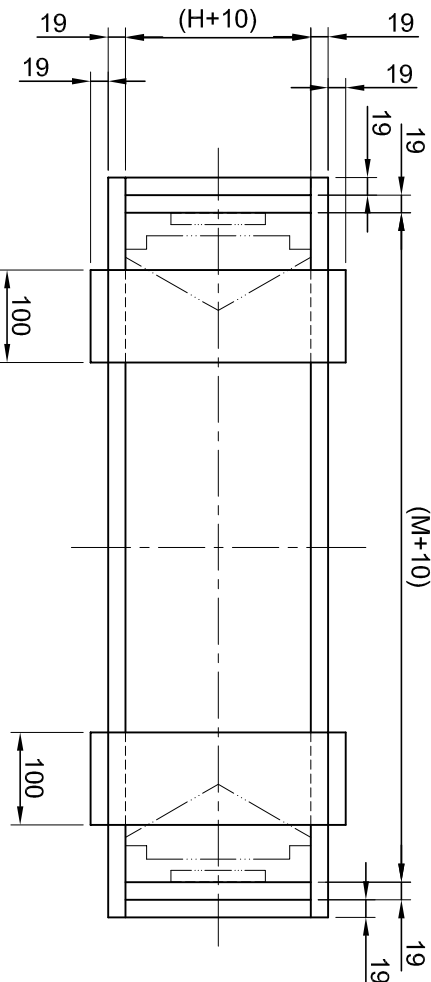

VAR. NO.	M	H	VOLUME OF WOOD REQUIRED	
			m ³	ft ³
13	788	180	0.02825	0.99763
12	742	180	0.02689	0.94961
11	350	215	0.01681	0.59363
10	689	180	0.02532	0.89416
09	655	120	0.02028	0.71618
08	610	120	0.01915	0.67627
07	548	120	0.01760	0.62153
06	495	100	0.01517	0.53572
05	443	100	0.01394	0.49228
04	389	89	0.01215	0.42907
03	343	89	0.01111	0.39234
02	324	89	0.01068	0.37716
01	305	89	0.01024	0.36162

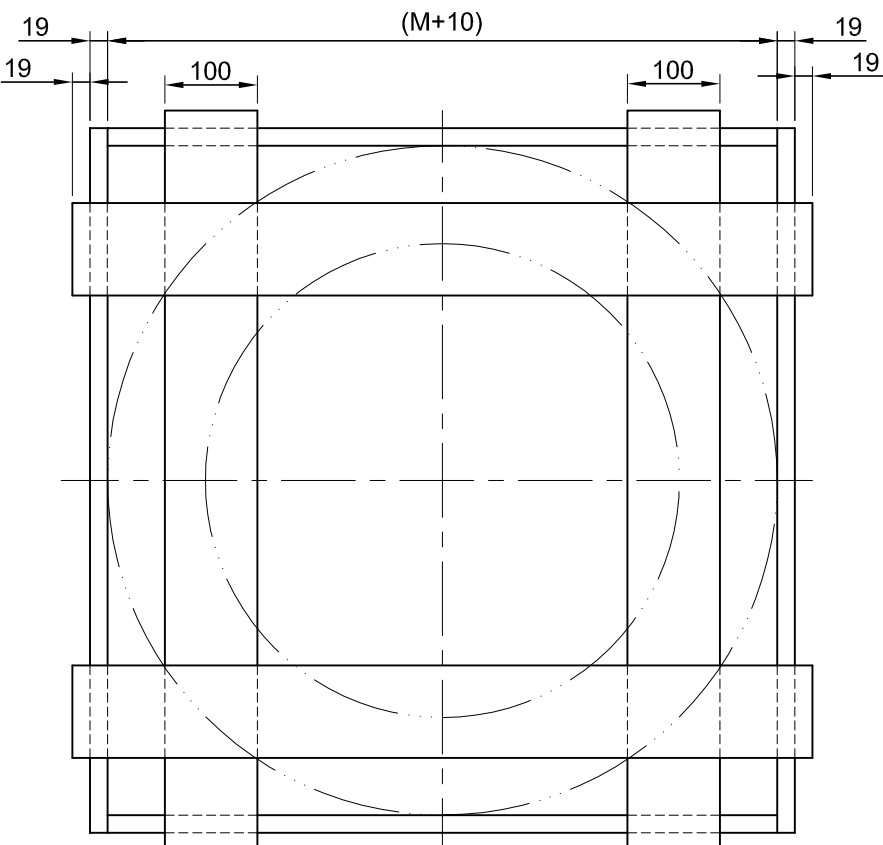
**NOTES:-**

- MATERIAL: WOOD AS PER GROUP I OR II OF IS: 6662 (LATEST REV.) AND AS PER DOCUMENT NO. JP-TP-17 (LATEST REV.)
- ALL JOINT SHOULD BE SECURED BY ADEQUATE NUMBERS OF WIRE NAILS.
- DIMENSIONS INDICATED REFER TO POST SHRINKAGE STAGE AND HENCE ARE MINIMUM ONES. DUE PROVISION FOR SHRINKAGE OF PLANKS SHOULD BE MADE BY THE VENDOR WHILE CUTTING THE SHOOKS.
- NAILS SHOULD BE DRIVEN AT 15° SLANT INSTEAD OF DRIVING VERTICALLY. EXCESS PORTION OF NAILS SHOULD BE BENDED OFF.
- BAND HOOP IRON 12 mm WIDTH 26 GAUGE BLUE FINISH SOFT VARIETY SHOULD BE FASTENED AT TWO PLACES.
- MATERIAL TO BE ACCEPTED ACCORDING TO ACCEPTANCE NORM JP-TP-15/GEN

ITEM NO.	DESCRIPTION	DIMENSIONS	MATERIAL	QTY.
07	NAIL	Ø2.5 x 50 LONG	IS:723	48
06	BATTEN	19 x 100 x (H+10)	SEE NOTE-1	04
05	BATTEN	19 x 100 x (H+48)	SEE NOTE-1	04
04	STAY PLANK	19 x (H+10) x (M+48)	SEE NOTE-1	02
03	STAY PLANK	19 x (H+10) x (M+10)	SEE NOTE-1	02
02	REINFORCEMENT PLANK	19 x 100 x (M+86)	SEE NOTE-1	04
01	STAY PLANK	19 x 100 x (M+86)	SEE NOTE-1	04

TOLERANCES:-

- ON THICKNESS OF PLANKS: ±1.0 mm
- ON LENGTH OF PLANKS: ±4.0 mm
- ON WIDTH OF PLANKS : +4.0 mm
-0

संशोधन REV.	दिनांक DATE	संशोधक ALTERED BY	Sd /=
03	11.02.13	शिवराम GHD	Sd /=

संशोधन REV.	दिनांक DATE	संशोधक ALTERED BY	Sd /=
02	03.03.12	शिवराम GHD	Sd /=

संशोधन REV.	दिनांक DATE	संशोधक ALTERED BY	Sd /=
01	21.09.04	शिवराम GHD	Sd /=

संशोधन REV.	दिनांक DATE	संशोधक ALTERED BY	Sd /=
04	16.03.15	शिवराम GHD	Sd /=

उत्पाद का प्रकार या ग्राहक/परियोजना का नाम
TYPE OF PRODUCT OR NAME OF
CUSTOMER/PROJECT

भारत हेवी इलेक्ट्रिकल्स लिमिटेड, जगदीशपुर, सीकराजपुरा नगर
BHARAT HEAVY ELECTRICALS LIMITED,
JAGDISHPUR, C.S.M. NAGAR

संशोधन REV.	दिनांक DATE	संशोधक ALTERED BY	Sd /=
04	16.03.15	शिवराम GHD	Sd /=

विभाग
DEPTT.

अभियंत्रिकी
ENGG.

कोड / CODE
400

पैमाना/SCALE
N.T.S.

भार कि. ग्रा.
WEIGHT (KG)

कार्ड कोड
CARD CODE

अभिकल्प संख्या/DRAWING NO.
3 CSK-111

REV. 04

REF. NO. - 2366

REF. NO. - 2314

REF. NO. - 1688

WOODEN BOX (FOR ORIFICES)

कार्ड कोड
CARD CODEअभिकल्प संख्या/DRAWING NO.
3 CSK-111

REV. 04

पृष्ठ संख्या/Sheets No. 01

पृष्ठों की संख्या/No. of Sheets 01

BHARAT HEAVY ELECTRICALS LIMITED
FSIP, JAGDISHPUR

SPECIFICATION NO:
JP-TP-15/GEN

PURCHASE SPECIFICATION

Page 1 of 1

VISUAL ACCEPTANCE NORMS FOR WOODEN PACKING CRATES

PHYSICAL APPEARANCE

- | | | |
|-----|----------------|---|
| 1.0 | CRACKS | <p>A. In two planks of one crate a seasonal crack of 25mm Max. will be allowed.</p> <p>B. For eucalyptus crate a seasonal crack of 10 mm length Max. in two planks per crate will be allowed.</p> |
| 2.0 | KNOTS | <p>A. Rotten knots not allowed.</p> <p>B. One knot in one plank. Max. 25 mm is allowed in two planks in one crates. (Not on the Ends & sides).</p> |
| 3.0 | CLEARANCE | Max. clearance between of two halves 6 mm. |
| 4.0 | BUCKLING | Not allowed |
| 5.0 | PROPER NAILING | Sharp end of Nails shall not be visible from outside. |

Prepared By

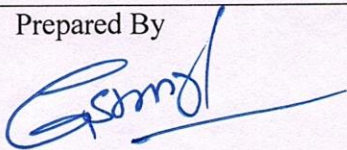

Functional Chief (Engineering)

Approved By



HOD (Engineering)

BHARAT HEAVY ELECTRICALS LIMITED
FSIP, JAGDISHPUR

PURCHASE SPECIFICATION

Document No. : JP-TP-17
Section Rev. No.: 00
Section Rev. Date: 04.07.19
Issue No: 01
Page 1 of 1

क्रेट बनाने हेतु इस्तेमाल की जाने वाली लकड़ियों की सूची

बी० एच० ई० एल० के पूर्वानुभवों के आधार पर निम्नलिखित लकड़ियाँ क्रेट बनाने हेतु उपयोग में लायी जा सकती हैं :-

अमरूद, अंजीर, आँवला, आम, अकेशिया, अकुहर, अशोक, अमलतास, अर्जुन, इमली, कयम, कैथा, कदम्ब, कनकोकन, कोरैया, गुलमोहर, चिलबिल, छेवहर, जामुन, नीम, बबूल (जंगली), बबूल (देशी), बेर, बेल, बबूल (शिव), बोटल ब्रश, शहतूत, सफेदा या यूकेलिप्टस (केवल अगस्त से मार्च तक), सागौन, शीशम, सिरसा, रीठा (कंजी), जंगल जलेबी ।

नोट:-

कृपया क्रेट बनाने हेतु निम्न लकड़ियों का प्रयोग न किया जाय :-

गूलर, पीपल, बरगद, पाकड़, महुआ, कथुमर, सेमर, छूल, सहजन, पलाश, कंजूर ।

Prepared By

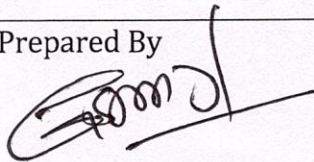

Functional Chief (Engineering)

Approved By

D2chanhan

HOD (Engineering)