	<b>BHEL</b> <b>Tenders</b>	<b>Government eProcurement System</b> <b>Tender Details</b>	Date : 21-May-2022 02:20 PM
	 Print		

### Basic Details

<b>Organisation Chain</b>	Bharat Heavy Electricals Limited  CFFP - Haridwar  CFFP		
<b>Tender Reference Number</b>	202200501		
<b>Tender ID</b>	2022_BHEL_12696_1		
<b>Tender Type</b>	Open Tender	<b>Form of contract</b>	Buy
<b>Tender Category</b>	Goods	<b>No. of Covers</b>	2
<b>General Technical Evaluation Allowed</b>	No	<b>ItemWise Technical Evaluation Allowed</b>	No
<b>Payment Mode</b>	Not Applicable	<b>Is Multi Currency Allowed For BOQ</b>	No
<b>Is Multi Currency Allowed For Fee</b>	No	<b>Allow Two Stage Bidding</b>	No

### Cover Details, No. Of Covers - 2

Cover No	Cover	Document Type	Description
1	Fee/PreQual/Technical	.pdf	Techno Commercial Bid
		.pdf	Terms and Conditions
2	Finance	.xls	Price Bid (BOQ)

### Tender Fee Details, [Total Fee in ₹ \* - 0.00]

<b>Tender Fee in ₹</b>	0.00		
<b>Fee Payable To</b>	Nil	<b>Fee Payable At</b>	Nil
<b>Tender Fee Exemption Allowed</b>	No		

### EMD Fee Details

<b>EMD Amount in ₹</b>	0.00	<b>EMD through BG/ST or EMD Exemption Allowed</b>	No
<b>EMD Fee Type</b>	fixed	<b>EMD Percentage</b>	NA
<b>EMD Payable To</b>	Nil	<b>EMD Payable At</b>	Nil

[Click to view modification history](#)

### Work /Item(s)

<b>Title</b>	Spur Gear, Bevel Gear etc.				
<b>Work Description</b>	Spur Gear, Bevel Gear etc.				
<b>Pre Qualification Details</b>	Please refer Tender documents.				
<b>Independent External Monitor/Remarks</b>	NA				
<b>Show Tender Value in Public Domain</b>	Yes				
<b>Tender Value in ₹</b>	5,00,000	<b>Product Category</b>	Mechanical Tools and Equipment	<b>Sub category</b>	NA
<b>Contract Type</b>	Tender	<b>Bid Validity(Days)</b>	120	<b>Period Of Work (Days)</b>	90
<b>Location</b>	CPS, CFFP, BHEL, HARIDWAR	<b>Pincode</b>	249403	<b>Pre Bid Meeting Place</b>	NA
<b>Pre Bid Meeting Address</b>	NA	<b>Pre Bid Meeting Date</b>	NA	<b>Bid Opening Place</b>	CFFP, BHEL, HARIDWAR (ONLINE)
<b>Should Allow NDA Tender</b>	No	<b>Allow Preferential Bidder</b>	No		

**Critical Dates**

<b>Publish Date</b>	21-May-2022 03:00 PM	<b>Bid Opening Date</b>	02-Jun-2022 04:00 PM
<b>Document Download / Sale Start Date</b>	21-May-2022 03:05 PM	<b>Document Download / Sale End Date</b>	02-Jun-2022 11:30 AM
<b>Clarification Start Date</b>	NA	<b>Clarification End Date</b>	NA
<b>Bid Submission Start Date</b>	21-May-2022 03:10 PM	<b>Bid Submission End Date</b>	02-Jun-2022 11:30 AM

**Tender Documents**

NIT Document	S.No	Document Name	Description	Document Size (in KB)
	1	Tendernotice_1.pdf	Techno Commercial Bid	531.19
	2	Tendernotice_2.pdf	Terms and Conditions	246.54

Work Item Documents	S.No	Document Type	Document Name	Description	Document Size (in KB)
	1	BOQ	BOQ_13421.xls	PRICE BID (BOQ)	330.50

**Bid Openers List**

S.No	Bid Opener Login Id	Bid Opener Name	Certificate Name
1.	rajesh.kur@bhel.in	Rajesh Kumar	RAJESH KUMAR
2.	hkjena@bhel.in	Hemant Kumar Jena	HEMANTA KUMAR JENA
3.	aktailor@bhel.in	Amit Kumar Tailor	AMIT KUMAR TAILOR
4.	arpitg@bhel.in	Arpit Gupta	ARPIT GUPTA

**GeMARPTS Details**

<b>GeMARPTS ID</b>	VG50VYTOF9KN
<b>Description</b>	SPUR GEAR AS PER DRAWING
<b>Report Initiated On</b>	16-May-2022
<b>Valid Until</b>	15-Jun-2022

**Tender Properties**

<b>Auto Tendering Process allowed</b>	No	<b>Show Technical bid status</b>	Yes
<b>Show Finance bid status</b>	Yes	<b>Show Bids Details</b>	Yes
BoQ Comparative Chart model	Normal	BoQ Compative chart decimal places	3
BoQ Comparative Chart Rank Type	L	Form Based BoQ	No

**Tender Inviting Authority**

<b>Name</b>	VINAY KUMAR SINGH
<b>Address</b>	PURCHASE DEPARTMENT, CFFP, BHEL, HARIDWAR- U.K. 249403

**Tender Creator Details**

<b>Created By</b>	Arpit Gupta
<b>Designation</b>	Deputy Manager
<b>Created Date</b>	20-May-2022 04:49 PM



**BHARAT HEAVY ELECTRICALS LIMITED**  
**CENTRAL FOUNDRY FORGE PLANT**  
**Purchase Department (Materials Management)**  
**Ranipur, Haridwar-249403 (Uttarakhand)**

<b>Tender Reference No.</b>	<b>Tender ID:2022_BHEL_12696_1</b>
<b>Item Description</b>	<b>Spur Gear, Bevel Gear etc.</b>
<b>Vendor Name</b>	
<b>Quotation Reference No.</b>	
<b>Currency</b>	<b>INR</b>

**Techno –Commercial Bid Details**

<b>S. No.</b>	<b>Description</b>	<b>Vendor Remarks</b>
1.	Dispatch mode (Road/Rail/Air/Sea)	
2.	Origin of Dispatch	
3.	Validity of the Offer ( <b>120 Days Min. excluding tender opening date</b> )	
4.	Prices shall be firm till execution of Order	
5.	<b>PAYMENT TERMS:</b> (Standard payment term is: 100% within 45 days after receipt subject to acceptance of material at CFFP / BHEL, Haridwar through e-payment. In case other payment term is quoted by vendor, proper loading shall be done. Base rate of SBI (as applicable on the date of bid opening: Techno commercial bid opening in case of two part bids) + 6%, shall be considered for loading for the period of relaxation sought by bidders.)	Agreed / comments
6.	ORDER TO BE PLACED ON	
7.	<b>Delivery Schedule:</b> 90 days from PO date. Early delivery is also acceptable.	Agreed / comments
8.	<b>Quantity variation</b> – Not Applicable	
9.	<b>Penalty for Late Delivery:</b> The delivery of the goods shall be made strictly as per time limit specified in delivery schedule of purchase order, failure to supply within this period will make the supplier liable to penalty of 1/2 (half) percent of the price of the goods in arrears per week subject to a maximum of 10%. In case LD clause is not agreed for full 10%, mention same in text field for agreed %age. Your offer shall be loaded for the un-agreed part (out of 10%). If deviation in penalty for late delivery then please specify.	Agreed / comments
10.	<b>Risk Purchase:</b> In case of delayed/defective supplies or non- fulfillment of any other terms & conditions given in the Purchase Order, the purchaser may cancel the purchase order in full or part thereof and may also make the purchase of such material at the risk & cost of supplier. In case of non- agreement of this term your offer shall not be considered.	Agreed / comments
11.	Splitting will be based on MSE clause 23 of General Terms & Condition: <b>For Indian Bidders (Version February-2022, Rev: 08)</b>	Agreed / comments
12.	CFFP/BHEL reserves the right to order part quantity.	Agreed / comments
13.	Final inspection shall be carried out after receipt of material at CFFP. However, CFFP reserves the right to pre Inspect the material at supplier works.	Agreed / comments



**BHARAT HEAVY ELECTRICALS LIMITED**  
**CENTRAL FOUNDRY FORGE PLANT**  
**Purchase Department (Materials Management)**  
**Ranipur, Haridwar-249403 (Uttarakhand)**

<b>Tender Reference No.</b>	<b>Tender ID:2022_BHEL_12696_1</b>
<b>Item Description</b>	<b>Spur Gear, Bevel Gear etc.</b>
<b>Vendor Name</b>	
<b>Quotation Reference No.</b>	
<b>Currency</b>	<b>INR</b>

<b>14.</b>	Guarantee Certificate is required for the period of one year from supply date.	
<b>15.</b>	Test certificate is required.	
<b>16.</b>	Are you registered under MSE? If yes, please send the copy of Udyog Aadhar Memorandum or Udyam Certificate. Please provide the same	
<b>17.</b>	Is MSE owned by SC/ST. If yes, attach copy of certificate.	
<b>18.</b>	CONTACT PERSON NAME	
<b>19.</b>	CONTACT EMAIL ADDRESSES	
<b>20.</b>	CONTACT MOBILE NOS.	
<b>21.</b>	Delivery Terms (Door Delivery CFFP Stores)	
<b>22.</b>	Read attached general terms & condition	
<b>23.</b>	In case of any difference in conditions quoted above & elsewhere in the offer, terms quoted above shall be treated as final and binding on vendor.	
<b>24.</b>	<p><b>Tie Breaker Clause:</b> In the course of evaluation, if more than one bidder happens to occupy L1 status, effective L1 will be decided by soliciting discounts from the respective L1 bidders.</p> <p>In case more than one bidder happens to occupy the L1 status even after soliciting discounts, the L1 bidder shall be decided by a toss/draw of lots, in the presence of the respective L1 bidder(s) or the representative(s).</p> <p>Ranking will be done accordingly. BHEL's decision in such situations shall be final and binding.</p>	
<b>25.</b>	All other terms & conditions not mentioned above, are as per General Terms & condition for <b>Indian Bidders (Version February-2022, Rev: 08)</b> .	
<b>26.</b>	For new vendors not registered with us, kindly furnish copy of following documents: a. Company Name and Address Proof. b. GST Number (Scan Copy of Acknowledgement) c. PAN Copy d. MSME Certificate (UAN, Udyam if Any) e. Bank certified EFT Mandate and cancelled cheque	
<b>27.</b>	Item no 1 & 2 are matching parts, so to be procured from same party.	
<b>28.</b>	Item no 3 & 4 are matching parts, so to be procured from same party.	





**BHARAT HEAVY ELECTRICALS LIMITED**  
**CENTRAL FOUNDRY FORGE PLANT**  
**Purchase Department (Materials Management)**  
**Ranipur, Haridwar-249403 (Uttarakhand)**

Tender Reference No.	Tender ID:2022_BHEL_12696_1
Item Description	Spur Gear, Bevel Gear etc.
Vendor Name	
Quotation Reference No.	
Currency	INR

29.	Item no 7 & 8 are matching parts, so to be procured from same party.	
30.	Item no 11,12,13,14,15.16 are matching parts, so to be procured from same party.	
31.	All teeth of gear & spline of shaft should be super finished grind.	

**Unpriced Bid Details (to submitted with Techno Commercial Bid)**

RFQ Item	1	2	3	4
Material Code	FF8251011019	FF8251011027	FF8251130123	FF8251130115
Item Name	DRG: 04-04-013 REV: SPUR GEAR (2ND SHAFT) FOR HEAD STOCK AS PER DRG.	DRG: 04-04-014 REV: SPUR GEAR (2ND SHAFT) FOR HEAD STOCK AS PER DRG.	DRG: 04-43-026 R0 REV: BEVEL GEAR AS PER DRG.	DRG: 04-43-016 R0 REV: BEVEL GEAR AS PER DRG.
Enquired Quantity	4 Nos.	4 Nos.	1 Nos.	1 Nos.
Offered Quantity				
Confirmation to supply the material as per BHEL CFFP Spec.				
Freight/ Unit				
Insurance/ Unit				
Packing/ Unit				
% GST				
Any other Charges				

**Note:**

- 1) Item no 1 & 2 are matching parts, so to be procured from same party.
- 2) Item no 3 & 4 are matching parts, so to be procured from same party.
- 3) Item no 7 & 8 are matching parts, so to be procured from same party.
- 4) Item no 11,12,13,14,15.16 are matching parts, so to be procured from same party.
- 5) All teeth of gear & spline of shaft should be super finished grind.



**BHARAT HEAVY ELECTRICALS LIMITED**  
**CENTRAL FOUNDRY FORGE PLANT**  
**Purchase Department (Materials Management)**  
**Ranipur, Haridwar-249403 (Uttarakhand)**

Tender Reference No.	Tender ID:2022_BHEL_12696_1
Item Description	Spur Gear, Bevel Gear etc.
Vendor Name	
Quotation Reference No.	
Currency	INR

RFQ Item	5	6	7	8
Material Code	FF8251590426	FF8251570212	FF8251600111	FF8251600197
Item Name	DRG: 04-45-004 R0. REV: SPUR GEAR AS PER DRG.	DRG: 04-33-011 R1 REV: SPLINE SHAFT FOR COLUMN MOVEMENT AS PER DRG.	DRG: DRG.NO- 04.21.002 REV: CARRIAGE PINION AS PER DRG.	DRG: 04-21- 030 R0 REV: FOURTH SHAFT WITH CHECK NUT AS PER DRG.
Enquired Quantity	1 Nos.	2 Nos.	1 Nos.	1 Nos.
Offered Quantity				
Confirmation to supply the material as per BHEL CFFP Spec.				
Freight/ Unit				
Insurance/ Unit				
Packing/ Unit				
% GST				
Any other Charges				

**Note:**

- 6) Item no 1 & 2 are matching parts, so to be procured from same party.
- 7) Item no 3 & 4 are matching parts, so to be procured from same party.
- 8) Item no 7 & 8 are matching parts, so to be procured from same party.
- 9) Item no 11,12,13,14,15,16 are matching parts, so to be procured from same party.
- 10) All teeth of gear & spline of shaft should be super finished grind.



**BHARAT HEAVY ELECTRICALS LIMITED**  
**CENTRAL FOUNDRY FORGE PLANT**  
**Purchase Department (Materials Management)**  
**Ranipur, Haridwar-249403 (Uttarakhand)**

Tender Reference No.	Tender ID:2022_BHEL_12696_1
Item Description	Spur Gear, Bevel Gear etc.
Vendor Name	
Quotation Reference No.	
Currency	INR

RFQ Item	9	10	11	12
Material Code	FF8251010616	FF8251520835	FF8251530172	FF8251530016
Item Name	DRG: 06-13-013 REV: SPUR GEAR WITH SPLINE BORE FOR FEED BOX FOR HMT MILLING MAC HINE FN 2U AS PER DRAWING.	DRG: 06-01-005 REV: SPUR GEAR AS PER DRAWING.	DRG: DRG.NO. 04-06-074 REV: SPUR GEAR OF RIGHT HEAD FOR VTB 2.5C	DRG: 04-06- 079 REV: BEVEL GEAR FOR FEED SHAFT GEAR BOX VTB 2.5 DRG NO. 04-06-079
Enquired Quantity	1 Nos.	1 Nos.	2 Nos.	2 Nos.
Offered Quantity				
Confirmation to supply the material as per BHEL CFFP Spec.				
Freight/ Unit				
Insurance/ Unit				
Packing/ Unit				
% GST				
Any other Charges				

**Note:**

- 11) Item no 1 & 2 are matching parts, so to be procured from same party.
- 12) Item no 3 & 4 are matching parts, so to be procured from same party.
- 13) Item no 7 & 8 are matching parts, so to be procured from same party.
- 14) Item no 11,12,13,14,15,16 are matching parts, so to be procured from same party.
- 15) All teeth of gear & spline of shaft should be super finished grind.



**BHARAT HEAVY ELECTRICALS LIMITED**  
**CENTRAL FOUNDRY FORGE PLANT**  
**Purchase Department (Materials Management)**  
**Ranipur, Haridwar-249403 (Uttarakhand)**

Tender Reference No.	Tender ID:2022_BHEL_12696_1
Item Description	Spur Gear, Bevel Gear etc.
Vendor Name	
Quotation Reference No.	
Currency	INR

RFQ Item	13	14	15	16
Material Code	FF8251530024	FF8251530032	FF8251530040	FF8251590035
Item Name	DRG: 04-06-080 REV: BEVEL PINION SHAFT OF FEED SHAFT GEAR BOX VTB 2.5 DRG. NO 04-06-080	DRG: 04-06-081 REV: SPUR PINION OF LHS GEAR BOX VTB 2.5 DRG NO. 04-06-081	DRG: 04-06- 082 REV: SPUR GEAR OF LHS GEAR BOX VTB 2.5 DRG.NO. 04- 06-082	DRG: 04-45- 008 REV: DISK (SPUR GEAR) OF COLUMN GEAR BOX HB 1-30 DRG. NO. 04-45-008
Enquired Quantity	2 Nos.	2 Nos.	2 Nos.	2 Nos.
Offered Quantity				
Confirmation to supply the material as per BHEL CFFP Spec.				
Freight/ Unit				
Insurance/ Unit				
Packing/ Unit				
% GST				
Any other Charges				

**Note:**

- 16) Item no 1 & 2 are matching parts, so to be procured from same party.
- 17) Item no 3 & 4 are matching parts, so to be procured from same party.
- 18) Item no 7 & 8 are matching parts, so to be procured from same party.
- 19) Item no 11,12,13,14,15,16 are matching parts, so to be procured from same party.
- 20) All teeth of gear & spline of shaft should be super finished grind.



842804/2022/CFFP-M&S\_PLGPSXCD

The information on this document is the property of BHARAT HEAVY ELECTRICALS LIMITED. It must not be used directly or indirectly in anyway detrimental to the interest of the company.

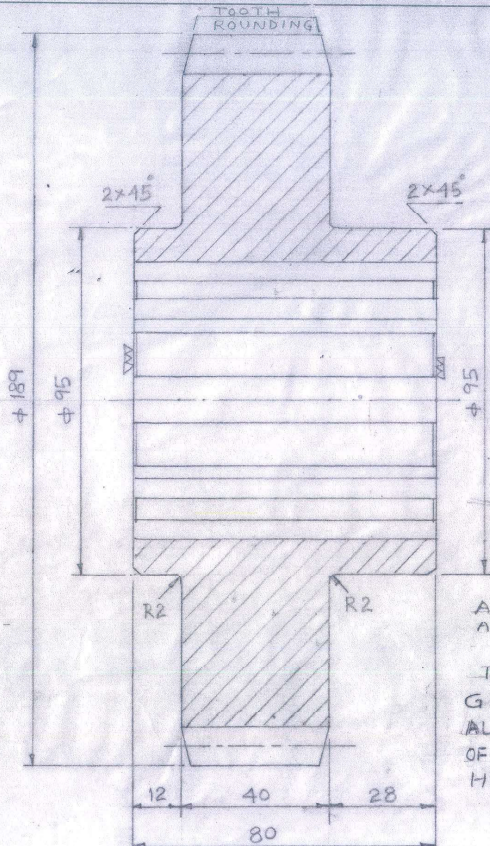

ALL TEETH & SPLINES HARDENING AT 830°-840°C  
 TEMPERING AT 180°-200°C  
 GEAR MATCHING DRG No. 04,03,008  
 ALL TEETH OF GEAR 2 SPLINES SHOULD BE OF SUPER FINISHED GRIND AFTER HARDENING

NO.	DESCRIPTIONS	DATA
1.	NO. OF TEETH	40
2.	MODULE	4.5
3.	PRESSURE ANGLE	20°
4.	TOOTH DEPTH	10
5.	TOOTH HARDENING HRC	50-55
6.	MATERIAL	EN-36
7.	SPLINE MATCHING DRG. NO.	04,03,003
	CENTER DISTANCE	137.25

**BHARAT HEAVY ELECTRICALS LTD.**  
 UNIT : CENTRAL FOUNDRY FORGE PLANT.  
 HARDWAR.

REV.	DATE	ALTERED CHECKED	REV.	DATE	ALTERED CHECKED	REV.	DATE	ALTERED CHECKED	DEPT.	SCALE	WEIGHT (KGS)	REF. to ASSY. DRG.	ITEM NO.
									F.E.	1:1			
TITLE: SPUR GEAR 5,6 M. CENTRE LATHE									DRAWN: [Signature] 3-11-22 CHECKED: P.P.R. [Signature] 24-04-22 APPROVED: V.S.M. [Signature] 24-04-22		DRAWING NO. 04,04,013 SHEET NO. 1 TOTAL SHEETS-1		REV. 0

Dimensions to be Controlled Within Limits as Shown  
 Machining Tolerance ± 0.25 mm Unless Otherwise Shown. Non Machining Tolerance ±



The information on this document is the property of BHARAT HEAVY ELECTRICALS LIMITED. It must not be used directly or indirectly in anyway detrimental to the interest of the company.

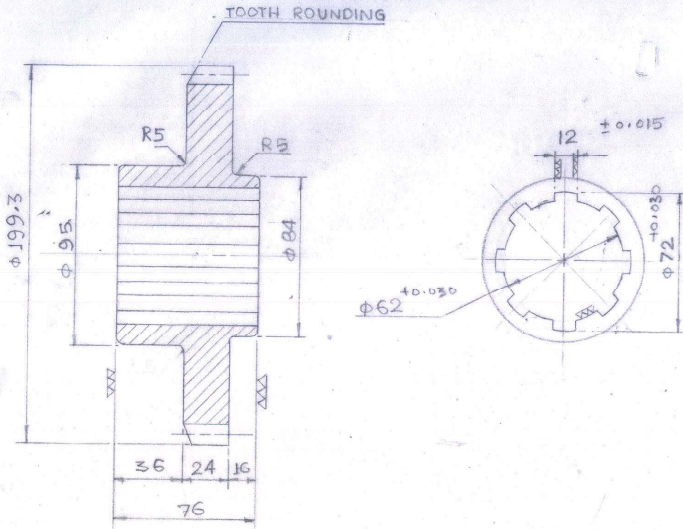

S.N	DESCRIPTION	DATA
1	NO. OF TEETH	12
2	MODULE	4.5
3	PRESSURE-ANGLE	20°
4	TOOTH-DEPTH	10
5	HARDENING	HRC- 55-60
6	MATERIAL	EN-26
7	SPLINE MATCHING DRG. No.	04.03.067
8	CENTER DISTANCE	137.25

ALL TEETH & SPLINES HARDENING AT 830°-840°C  
 TEMPERING AT 180°-200°C  
 GEAR SHOULD BE MATCH WITH DRG. NO. 04,03,067  
 ALL TEETH OF GEAR & SPLINES SHOULD BE OF SUPER FINISHED GRIND. AFTER HARDENING.

**BHARAT HEAVY ELECTRICALS LTD.**  
 UNIT : CENTRAL FOUNDRY FORGE PLANT.  
 HARDWAR.

REV.	DATE	ALTERED		REV.	DATE	ALTERED		REV.	DATE	ALTERED		DEPTT.	SCALE	WEIGHT (KGS)	REF. to ASSY. DRG.	ITEM NO.
		CHECKED				CHECKED				CHECKED						
												FE	1:2			
TITLE: SPUR-GEAR 5,6M LATHE M/C SHOP													NAME: V.S. NIGI SIGN: [Signature] DATE: 4/29/22			
Dimensions to be Controlled Within Limits as Shown Machining Tolerance ± 0.25 mm Unless Otherwise Shown. Non Machining Tolerance ±													DRAWING NO. 04-04-014 SHEET NO. 1 NO. OF SHEETS 1			

Inventory No. FF225101027

The information on this document is the property of BHARAT HEAVY ELECTRICALS LTD. It must not be used directly or indirectly in anyway detrimental to the interest of the Company.

Ref. Orig. No.

Sign & Date

Inventory No.

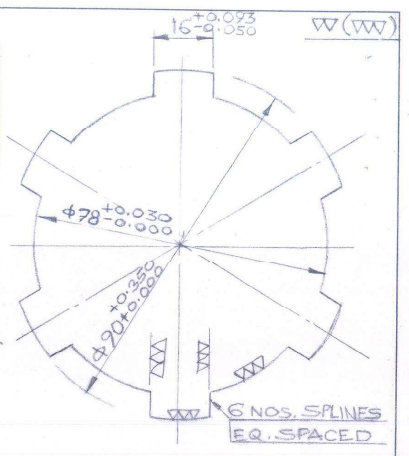
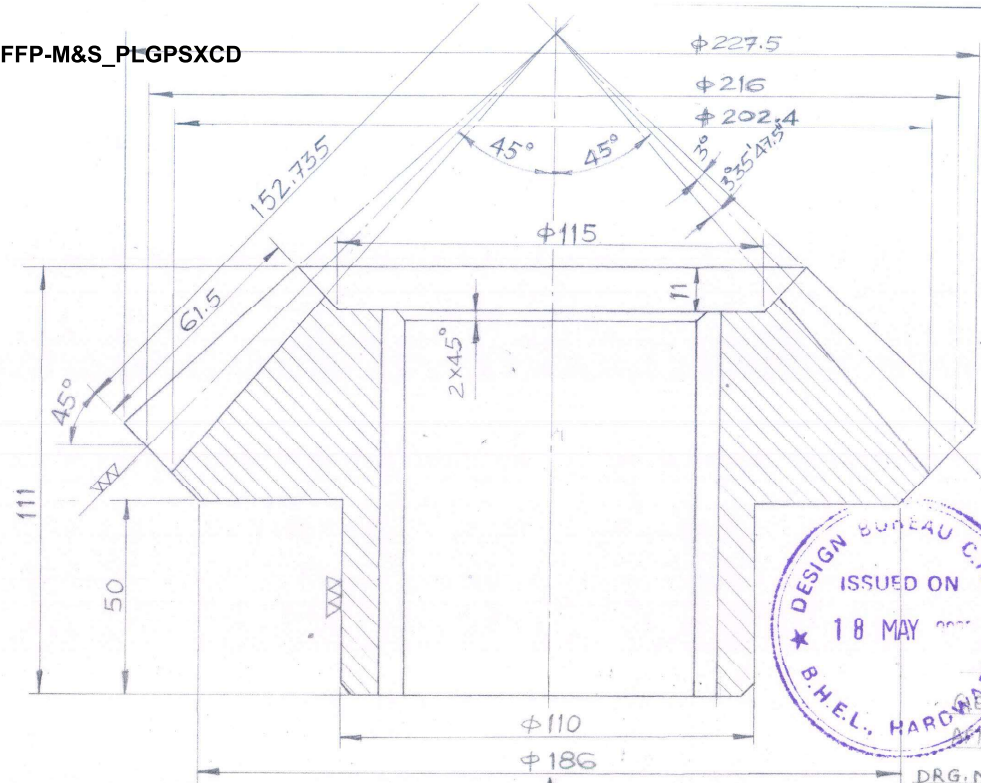

NO. OF TEETH : 27  
MODULE : 8 (MAX)  
PRESSURE ANGLE : 20 INVOLUTE  
TOOTH HARDENING : HRC 45-50  
MATCHING DRG NO. : 04,43,016  
TEETH SHOULD BE GRIND FINISH  
AFTER HARDENING.

DRG. NO. TO BE PUNCHED ON THE ITEM.

MATERIAL :  
**En 24**

<b>BHARAT HEAVY ELECTRICALS LTD.</b>		<b>UNIT : CENTRAL FOUNDRY FORGE PLANT</b>		<b>HARDWAR</b>	
DEPTT. DESIGN	SCALE 1:1	WEIGHT (KGS.) 3.00	REF. to ASSY. DRG.	ITEM NO.	
TITLE <b>BEVEL GEAR (TAIL STOCK)</b>			NAME	SIGN	DATE
14M CENTRE LATHE (BECO) MIC SHOP			DRAWN	K.LAL	16.10.18
Dimensions to be Controlled Within Limits as Shown Machining Tolerance: 0.25 mm Unless Otherwise Shown. Non Machining Tolerance ±			CHECKED	SAGAR	
			APPROVED		
			DRAWING NO. <b>04.43.026</b>	REV. <b>0</b>	
			SHEET NO. <b>1</b>	NO. OF SHEETS <b>1</b>	

REV.	DATE	ALTERED	CHECKED	REV.	DATE	ALTERED	CHECKED	REV.	DATE	ALTERED	CHECKED

FF 825/1130123





The information on this document is the property of BHARAT HEAVY ELECTRICALS LIMITED. It must not be used directly or indirectly in any way detrimental to the interest of the company.

Ref. Dwg. No. SAMPLE

Sign & Date

Inventory No. FF8251130115

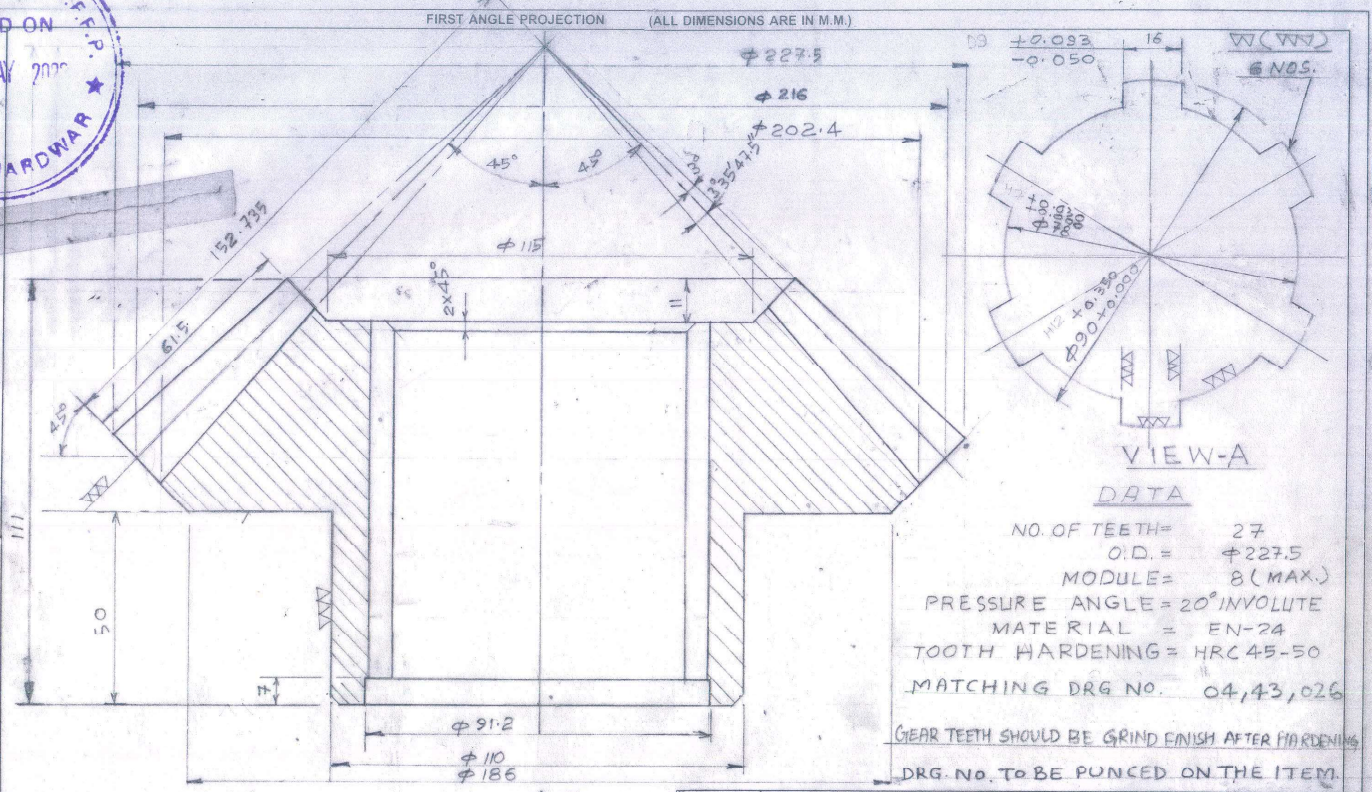

ALL SHARP CORNERS TO BE ROUNDED OFF. MATERIAL- EN-24

**BHARAT HEAVY ELECTRICALS LIMITED.**  
 UNIT: CENTRAL FOUNDRY FORGE PLANT.  
 HARDWAR

REV.	DATE	ALTERED CHECKED	REV.	DATE	ALTERED CHECKED	REV.	DATE	ALTERED CHECKED	DEPTT.	SCALE	WEIGHT (KGS.)	REF. to ASSY. DRG.	ITEM NO.	
									DESIGN BUREAU	1:1	0.00			
TITLE: BEVEL GEAR (TAIL STOCK) (NO MOTION) 14 M CENTRE LATHE (BECO) MACHINE SHOP										DRAWN	GUPTA AK	REV	15.09.04	
Dimensions to be controlled Within Limits as Shown Machining Tolerance $\pm 0.25$ mm Unless Otherwise Shown. Non Machining Tolerance $\pm$										CHECKED	GUPTA PB			
										APPROVED	GUPTA PB		11-11-02	
										DRAWING NO.	04.43.016		REV.	0
										SHEET NO.	01	NO. OF SHEETS	01	



FIRST ANGLE PROJECTION (ALL DIMENSIONS ARE IN mm)

REV.	DATE.	ALTERED	REV.	DATE.	ALTERED
		CHECKED			CHECKED

The information on this document is the property of BHARAT HEAVY ELECTRICALS LIMITED. It must not be used directly or indirectly in anyway detrimental to the interest of the company.

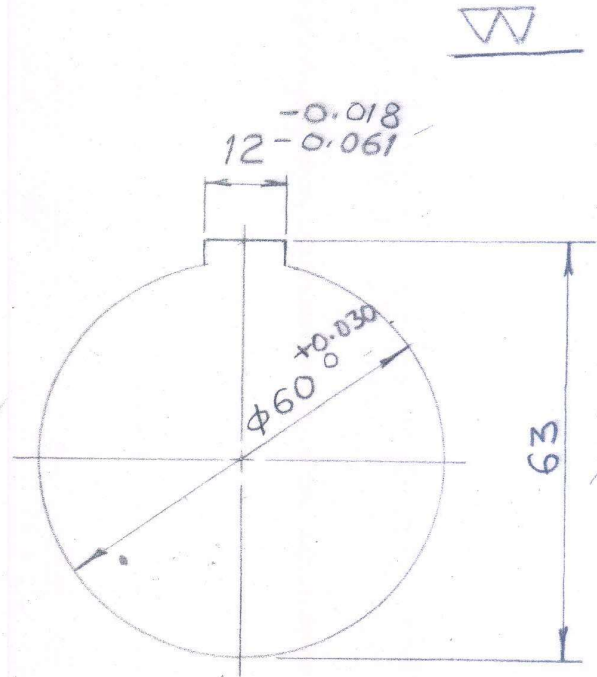
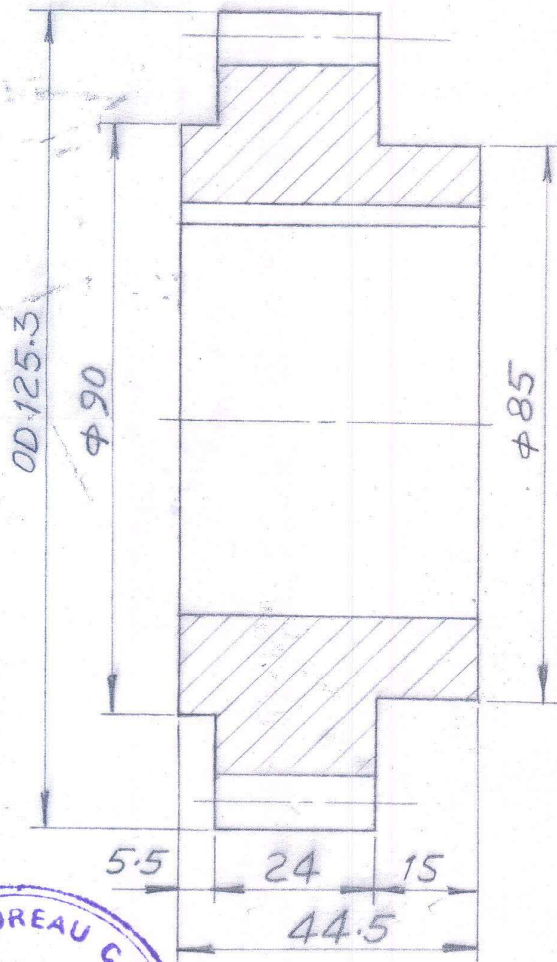

- NO. OF TEETH : 33
- MODULE : 3.5
- TOOTH DEPTH : 8
- PRESSURE ANGLE : 20°
- CORRECTION FACTOR : +0.4
- MATERIAL : EN 24

NOTE → TEETH MATCH WITH DR No- 04, 45, 005  
HRC 45-50



**BHARAT HEAVY ELECTRICALS LTD.**  
UNIT: CENTRAL FOUNDRY FORGE PLANT.  
HARDWAR.

DEPT. DESIGN		SCALE 1:1	WEIGHT (KGS.)	REF. to ASSY. DRG.	ITEM NO.
--------------	--	-----------	---------------	--------------------	----------

SPUR GEAR HEAD STOCK SPINDLE DRIVE			
1-30 HORIZONTAL BORER M/C SHOP			
DRAWN	NAME IQBAL	SIGN.	DATE 08.03.11
CHECKED	K.LAL		17.03.11
APPROVED	V.SAGAR	Vidya	18.03.11

DRAWING NO.	REV.
04, 45, 004	0
SHEET NO.	NO. OF SHEETS.
	1

Inventory No. FF 8251590426





842804/2022/CFFP-M&S\_PLGPSXCD

FIRST ANGLE PROJECTION (ALL DIMENSIONS ARE IN mm)

The information on this document is the property of BHARAT HEAVY ELECTRICALS LIMITED. It must not be used directly or indirectly in anyway detrimental to the interest of the company.

W (WV)

NO.	DESCRIPTIONS	DATA
1.	NO. OF TEETH	13
2.	MODULE	5
3.	PRESSURE ANGLE	20°
4.	TOOTH DEPTH	11.5
5.	TOOTH HARDENING HRC	45-50
6.	MATERIAL $\Delta$	EN 24
7.	PART. NO.	17803
8.	CORRECTION FACTOR	ZERO
9.	MATCHING DRG. NO.	04-21-003

VIEW - A

1. ALL TEETH OF GEAR SHOULD BE OF SUPER FINISHED GRIND AFTER HARDENING.

2. ALL TEETH OF GEAR HARDENING AT 830°-840°c, TEMPERED AT 180°-200°c

TYPE OF PRODUCT, OR NAME OF CUSTOMER /PROJECT

**BHARAT HEAVYELECTRICALS LTD.**  
UNIT: C.F.F.P., HARDWAR.

DEPT. CODE SCALE 1:2 WEIGHT (KG) REF. TO ASSY. DRG. ITEM NO.

PINION  
DHB - CARRIAGE.

FOR A USE NAME SIGN. DATE

CHECKED *Chandra* 8-2-88

APPROVED

REV. DATE ALTERED V. SAGAR

R1 7.8.19 CHECKED

MATERIAL CHANGED FROM EN 18 TO EN 24 & ADD TOOTH ROUNDING & NOTES

Dimensions to be Controlled Within Limits as Shown  
Machining Tolerance  $\pm$  .25 mm Unless Otherwise Shown, Non Machining Tolerance  $\pm$

CARD CODE

DRAWING NO. 04-21-002 15 TO REV. 1

SHEET NO. 1 NO. OF SHEETS, 1

FF-8251600111 Inventory No.



The information on this document is the property of BHARAT HEAVY ELECTRICALS LIMITED. It must not be used directly or indirectly in any way detrimental to the interest of the company.

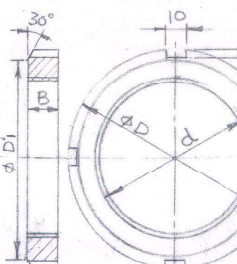
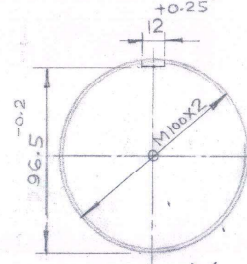
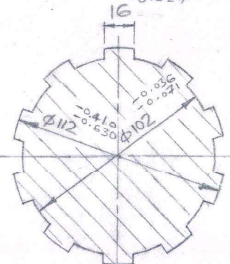
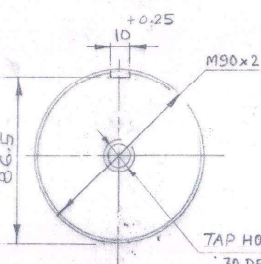
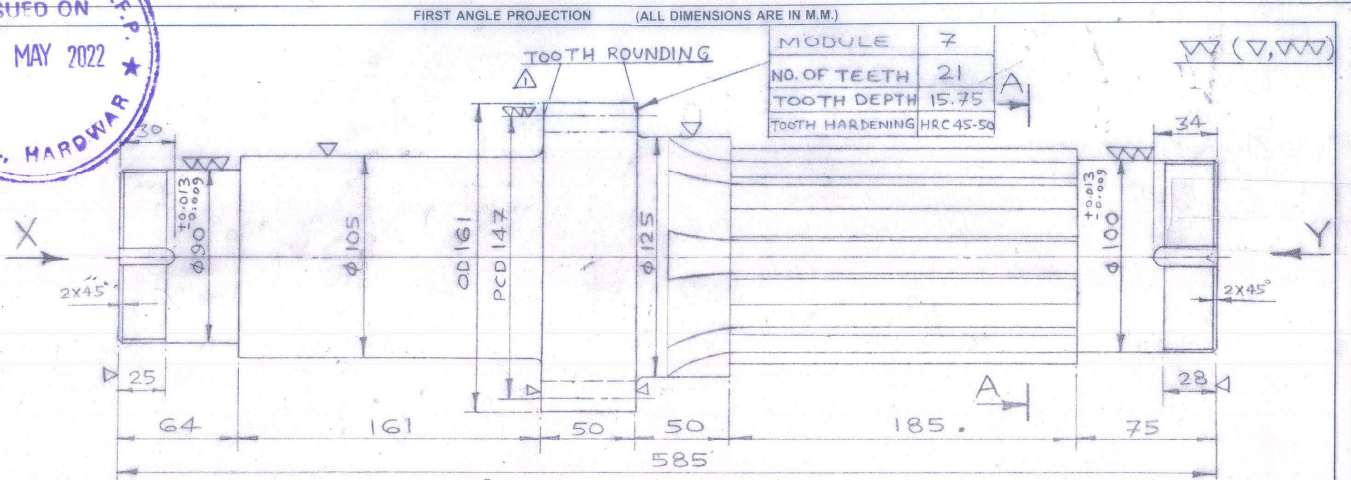

SIZED	d	φ D	φ D1	B
M90x2	120	108	16	
M100x2	130	120	18	

Inventory No. FF8251600197

Sign & Date

GEAR TEETH & SPLINE HARDENING AT 830°-840°C, TEMPERED AT 180°-200°C  
 GEAR TEETH & SPLINES SHOULD BE GRIND FINISH AFTER HARDENED  
 ALL SHARP CORNERS TO BE ROUNDED OFF.

MATERIAL - EN 24

**BHARAT HEAVY ELECTRICALS LIMITED.**  
 UNIT: CENTRAL FOUNDRY FORGE PLANT.  
**HARDWAR**

REV.	DATE	ALTERED CHECKED	REV.	DATE	ALTERED CHECKED	REV.	DATE	ALTERED CHECKED
						R1	7.8.19	✓

NOTE & TOOTH ROUNDING ADDED AS MARK ⚠

DEPTT. DESIGN BUREAU	SCALE 1:2	WEIGHT(KGS.) 43.2 kg.	REF. to ASSY. DRG.	ITEM NO.
TITLE: FOURTH SHAFT WITH CHECK NUT FOR CUTTER HEAD DHB, FRB 110				
DRAWN KISHORILA	CHECKED	APPROVED PBG	DATE 7.6.04	REV. R1
DRAWING NO. 04, 21, 030		SHEET NO. 1 NO. OF SHEETS 1		

Dimensions to be controlled Within Limits as Shown  
 Machining Tolerance: ± 0.25 mm Unless Otherwise Shown. Non Machining Tolerance ±



FIRST ANGLE PROJECTION ( ALL DIMENSIONS ARE IN mm )

REV	DATE	ALTERED	REV	DATE	ALTERED
		CHECKED			CHECKED

TEETH HARDENING AT 830°-840°  
 TEETH SHOULD BE GRIND AFTER HARDENING  
 TEMPERING AT 180°-200°C

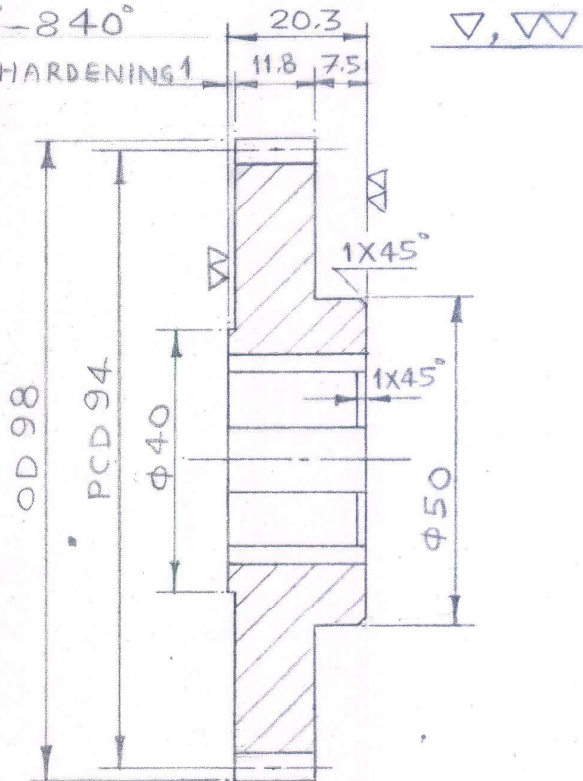
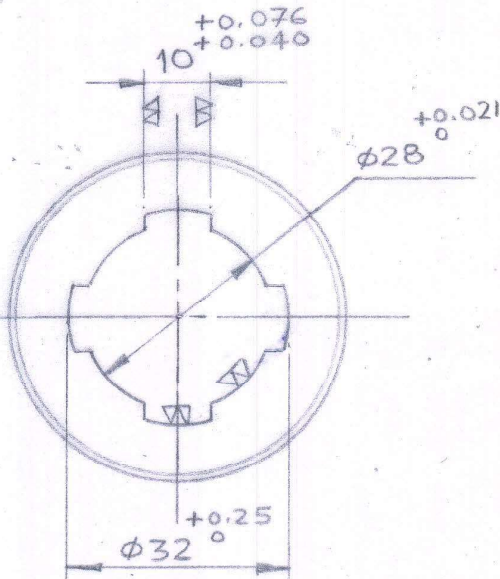

MATERIAL: EN36

PART NO. D237-300-3

NO. OF TEETH	49
MODULE	2
PRESSURE ANGLE	20°
CORRECTION FACTOR	-1

TOOTH HARDNESS  
HRC 45-50

MATCHING DRG. NO. 06,13,014

ALL SHARP CORNERS TO BE ROUNDED OFF.



Sign. & Date



**BHARAT HEAVY ELECTRICALS LTD.**  
 UNIT: C.F.F.P., HARDWAR.

DEPT. DESIGN	CODE	SCALE 1:1	WEIGHT (KG) 0.65	REF. TO ASSY. DRG.	ITEM NO.
--------------	------	-----------	------------------	--------------------	----------

SPUR GEAR  
 WITH SPLINE BORE  
 FOR FEED BOX  
 FN 20 HMT MILLING M/C Q.M.

	NAME	SIGN.	DATE
DRAWN	K.LAL	[Signature]	14.3.02
CHECKED	PBG?	[Signature]	
APPROVED	PBG?	[Signature]	30.3.02

Dimensions to be Controlled Within Limits as Shown  
 Machining Tolerance + .25 mm Unless Otherwise  
 Shown. Non Machining Tolerance ±

CARD CODE

DRAWING NO. 15 16 REV. 17

06,13,013 0

SHEET NO. 1 NO. OF SHEETS. 1

SIZE A4

Inventory No. FF025100616

ALL DIMENS. ARE IN M.M.

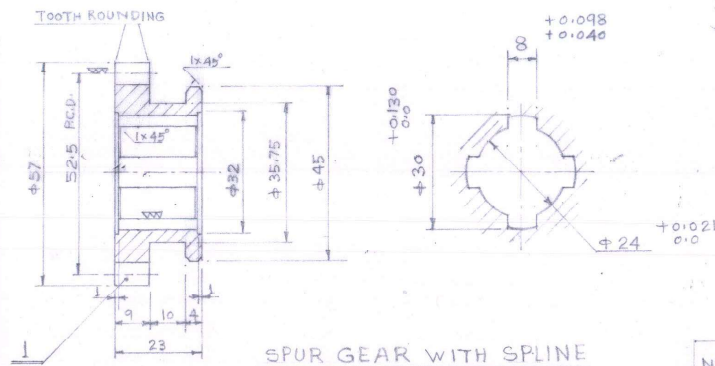

SPUR GEAR WITH SPLINE

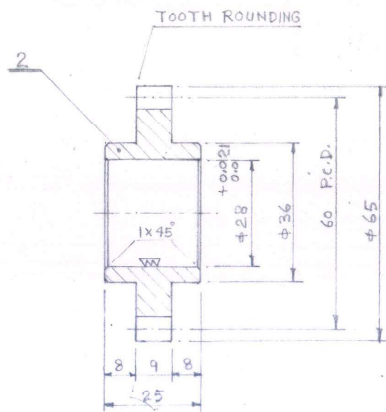

SPUR GEAR

NO.	DESCRIPTIONS	SPUR GEAR WITH SPLINE-1	SPUR GEAR 2
1	NO. OF TEETH	21	24
2	MODULE	2.5	2.5
3	PRESSURE ANGLE	20°	20°
4	TOOTH DEPTH	6	6
6	HARDENING	HRC. →	45-50
7	MATERIAL	EN - 36	

TEETH HARDENING AT 830° - 840°C  
 TEETH SHOULD BE GRIND AFTER HARDENING  
 TEMPERING AT 180° - 200°C



**BHARAT HEAVY ELECTRICALS LTD.**  
 UNIT : CENTRAL FOUNDRY FORGE PLANT.  
 HARDWAR.

DEPTT.	SCALE 1:1	WEIGHT (KGS)	SAMPLE.		
TITLE	SPUR GEAR FOR MILLING MACHINE (BATLIBOI) T.S.		DRAWN	NAME	SIGN
			WORKED	Ashok Kumar	Ashok
			CHECKED	PARAG GUPTA	
			APPROVED	PARAG GUPTA	
UNSPECIFIED TOL. 0.15			DRAWING NO.	06-01-005	
			SHEET NO.	NO OF SHEETS	

INVENTORY NO. FE 8251520835



FIRST ANGLE PROJECTION
(ALL DIMENSIONS ARE IN mm)
FORM: DG-38(B)

DRAWING NO. 04-06-074

NO. OF TEETH 53

MODULE 2.5

PRESSURE ANGLE 20°

TOOTH HARDNESS HRC 45-50

NOTE :-

1. ALL SHARP CORNERS TO BE ROUNDED OFF.
2. GEAR TEETH SHOULD BE GRIND FINISH AFTER HARDENING
3. DRG. NO. TO BE PUNCH ON THE ITEM.

MATERIAL: EN 24

REV.	DATE	ALTERED	CHECKED	DEPT.	SCALE	WEIGHT(Kg.)	REF. TO ASSY. DRG.	ITEM NO.	NO. OF ITEMS
					NTS				

BHARAT HEAVY ELECTRICALS LTD.				NAME	SIGN	DATE	NO. OF
UNIT: CENTRAL FOUNDRY FORGE PLANT				DRN	ANAMIKA	06.01.20	VAR.
HARDWAR				CHD	ANAMIKA	06.01.20	
				APD	VIDYA		

TITLE		DRAWING NO.	
SPUR GEAR		04-06-074	
OF RIGHT HEAD		0	
FOR VTB 2.5C, M/C SHOP		SHEET NO. 1	
		NO. OF SHEETS 1	

SIZE A3

COPYRIGHT AND CONFIDENTIAL  
THE INFORMATION ON THIS DOCUMENT IS THE PROPERTY OF  
BHARAT HEAVY ELECTRICALS LIMITED. IT MUST NOT BE USED DIRECTLY  
OR INDIRECTLY IN ANY WAY DETRIMENTAL TO THE INTEREST OF THE COMPANY.

FF8251530172



DRAWING NO. 04-06-079

FIRST ANGLE PROJECTION

(ALL DIMENSIONS ARE IN mm)

FORM: DG-38(B)

1.6/ THE REST

Technical drawing of a bevel gear. The front view shows a circular gear with a diameter of 63.5 ± 0.2 mm and a central hole with a diameter of 26.0 ± 0.02 mm. The side view shows a bevel gear with a pitch diameter of 86.417 mm, an outer diameter of 136.097 mm, and a pitch circle diameter of 130 mm. The gear has 26 teeth with a module of 5 and a pressure angle of 20°. The tooth hardness is HRC 45-50. The material is EN 24. The gear is made of steel and is used in a feed shaft gear box for VTB 2.5, M/C SHOP.

**NOTES:-**

- GEAR TEETH SHOULD BE GRIND FINISH AFTER HARDENING.
- MATCHING DRAWING NO. 04-06-080.
- ALL SHARP CORNERS TO BE ROUNDED OFF.
- DRAWING NO. TO BE PUNCHED AT SUITABLE PLACE.

NO. OF TEETH	26
MODULE	5
PRESSURE ANGLE	20°
TOOTH HARDENING	HRC 45-50
MATERIAL	EN 24

<b>BHIL</b>	BHARAT HEAVY ELECTRICALS LTD.	NAME	SIGN	DATE	NO. OF VAR.
	UNIT: CENTRAL FOUNDRY FORGE PLANT	DRN	T.MANDAL	23.03.22	
	HARDWAR	CHD	T.MANDAL		
		APD	KUMAWAT		

DEPT. M&S	SCALE	WEIGHT	REF. TO ASSY. DRG.
CODE	1:1		

TITLE	DRAWING NO.
BEVEL GEAR	04-06-079
OF FEED SHAFT GEAR BOX	
FOR VTB 2.5, M/C SHOP	
	SHEET NO. 01   NO. OF SHEETS 01

DIMENSIONS TO BE CONTROLLED WITHIN LIMITS AS SHOWN MACHINING TOLERANCE ±0.25mm UNLESS OTHERWISE SHOWN.

REV.	DATE	ALTERED	CHECKED

INVENTORY NO. FF8251530016

SIGN & DATE

3620-70/6 REF. DRG NO.

COPYRIGHT AND CONFIDENTIAL THE INFORMATION ON THIS DOCUMENT IS THE PROPERTY OF BHARAT HEAVY ELECTRICALS LIMITED. IT MUST NOT BE USED DIRECTLY OR INDIRECTLY IN ANY WAY DETRIMENTAL TO THE INTEREST OF THE COMPANY.





COPYRIGHT AND CONFIDENTIAL  
 THE INFORMATION ON THIS DOCUMENT IS THE PROPERTY OF  
 BHARAT HEAVY ELECTRICALS LIMITED. IT MUST NOT BE USED DIRECTLY  
 OR INDIRECTLY IN ANY WAY DETRIMENTAL TO THE INTEREST OF THE COMPANY.

INVENTORY NO. FF8251530024

SIGN & DATE  
 REF. DRG NO.

REV. DATE ALTERED CHECKED  
 REV. DATE ALTERED CHECKED

DIMENSIONS TO BE CONTROLLED WITHIN LIMITS AS SHOWN MACHINING  
 TOLERANCE  $\pm 0.25\text{mm}$  UNLESS OTHERWISE SHOWN.

FIRST ANGLE PROJECTION (ALL DIMENSIONS ARE IN mm)

FORM: DG-38(B)

1.6 THE REST

DESIGN BUREAU C.F.P.P.  
 ISSUED ON 18 MAY 2022  
 B.H.E.L. HARDWAR

DRAWING NO. 04-06-080

SECTION AA  
 DETAIL B

NO. OF TEETH	20
MODULE	5
PRESSURE ANGLE	20°
TOOTH HARDENING	HRC 45-50
MATERIAL	EN 24

NAME	SIGN	DATE	NO. OF VAR.
DRN T.MANDAL		23.03.22	
CHD T.MANDAL			
APD KUMAWAT			

DEPT. M&S	SCALE 1:1	WEIGHT	REF. TO ASSY. DRG.	ITEM NO.	NO. OF ITEMS
CODE					

TITLE BEVEL PINION SHAFT  
 OF FEED SHAFT GEAR BOX  
 FOR VTB 2.5, M/C SHOP

DRAWING NO. 04-06-080  
 SHEET NO. 01 NO. OF SHEETS 01

SIZE A3

COPYRIGHT AND CONFIDENTIAL  
 THE INFORMATION ON THIS DOCUMENT IS THE PROPERTY OF  
 BHARAT HEAVY ELECTRICALS LIMITED . IT MUST NOT BE USED DIRECTLY  
 OR INDIRECTLY IN ANY WAY DETRIMENTAL TO THE INTEREST OF THE COMPANY

DRAWING NO. 04-06-081

FIRST ANGLE PROJECTION

(ALL DIMENSIONS ARE IN mm)

FORM: DG-38(B)

1.8/ ALL OVER

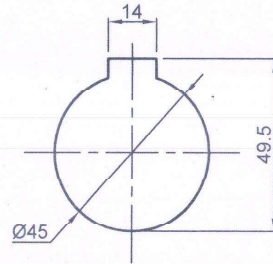
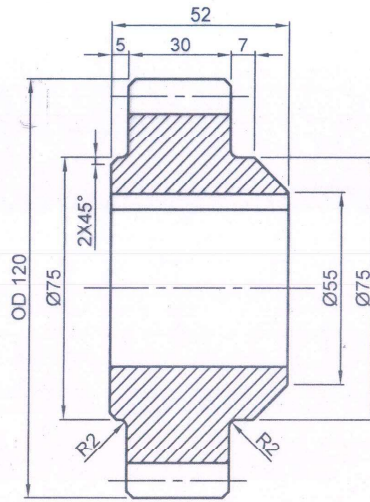

**NOTES:-**

1. GEAR TEETH SHOULD BE GRIND FINISH AFTER HARDENING.
2. ALL SHARP CORNERS TO BE ROUNDED OFF.
3. DRAWING NO. TO BE PUNCHED AT SUITABLE PLACE.

NO. OF TEETH	22
MODULE	5
PRESSURE ANGLE	20°
TOOTH HARDENING	HRC 45-50
MATERIAL	EN 24

FF8251530032

INVENTORY NO. SIGN & DATE REF. DRG NO.

REV.	DATE	ALTERED	REV.	DATE	ALTERED
		CHECKED			CHECKED

BHARAT HEAVY ELECTRICALS LTD. UNIT: CENTRAL FOUNDRY FORGE PLANT HARDWAR		NAME T. MANDAL	SIGN 	DATE 23.03.22	NO. OF VAR.
DEPT. M&S CODE	SCALE 1:1	WEIGHT	REF. TO ASSY. DRG.	APP KUMAWAT	ITEM NO.
TITLE <b>SPUR PINION</b> OF LHS GEAR BOX FOR VTB 2.5, M/C SHOP			DRAWING NO. <b>04-06-081</b>		NO. OF ITEMS
			SHEET NO. 01	NO. OF SHEETS 01	NO. OF ITEMS 01

DIMENSIONS TO BE CONTROLLED WITHIN LIMITS AS SHOWN MACHINING TOLERANCE ±0.25mm UNLESS OTHERWISE SHOWN.

SIZE A3



842804/2022/CFFP-M&S\_PLGPSXCD

FIRST ANGLE PROJECTION

(ALL DIMENSIONS ARE IN mm)

FORM: DG-38(B)

DRAWING NO. 04-06-082

1.6/ALL OVER

COPYRIGHT AND CONFIDENTIAL  
 THE INFORMATION ON THIS DOCUMENT IS THE PROPERTY OF  
 BHARAT HEAVY ELECTRICALS LIMITED. IT MUST NOT BE USED DIRECTLY  
 OR INDIRECTLY IN ANY WAY DETRIMENTAL TO THE INTEREST OF THE COMPANY.

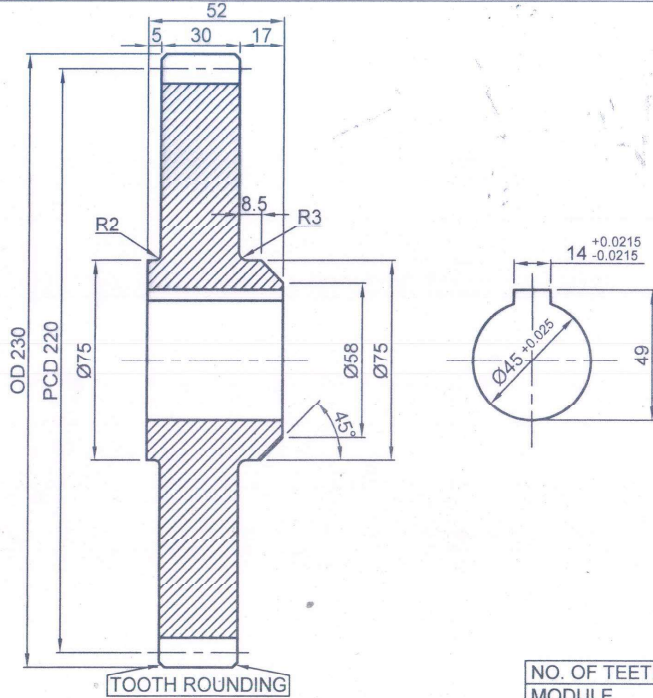

NOTES:-

1. GEAR TEETH SHOULD BE GRIND FINISH AFTER HARDENING.
2. ALL SHARP CORNERS TO BE ROUNDED OFF.
3. DRAWING NO. TO BE PUNCHED AT SUITABLE PLACE.

NO. OF TEETH	44
MODULE	5
PRESSURE ANGLE	20°
TOOTH HARDENING	HRC 45-50
MATERIAL	EN 24

FF8251530040

INVENTORY NO. SIGN & DATE REF. DRG NO.

REV.	DATE	ALTERED CHECKED	REV.	DATE	ALTERED CHECKED

BHARAT HEAVY ELECTRICALS LTD. UNIT: CENTRAL POUNDRY FORGE PLANT HARDWAR		NAME DRN T.MANDAL CHD T.MANDAL APD KUMAWAT	SIGN 	DATE 29.03.22	NO. OF VAR. 75, 74 75, 72
DEPT. M&S	SCALE 1:1	WEIGHT	REF. TO ASSY. DRG.		ITEM NO.
CODE	TITLE <b>SPUR GEAR</b> OF LHS GEAR BOX FOR VTB 2.5, M/C SHOP		DRAWING NO. <b>04-06-082</b>		NO. OF ITEMS 22, 23, 24 01
DIMENSIONS TO BE CONTROLLED WITHIN LIMITS AS SHOWN MACHINING TOLERANCE ±0.25mm UNLESS OTHERWISE SHOWN.			SHEET NO. 01 NO. OF SHEETS 01		SIZE A3

FIRST ANGLE PROJECTION

(ALL DIMENSIONS ARE IN mm)

COPYRIGHT AND CONFIDENTIAL  
 THE INFORMATION ON THIS DOCUMENT IS THE PROPERTY OF  
 BHARAT HEAVY ELECTRICALS LIMITED . IT MUST NOT BE USED DIRECTLY  
 OR INDIRECTLY IN ANY WAY DETRIMENTAL TO THE INTEREST OF THE COMPANY

REV.	DATE	ALTERED CHECKED	REV.	DATE	ALTERED CHECKED	REV.	DATE	ALTERED CHECKED

1.6/ALL OVER

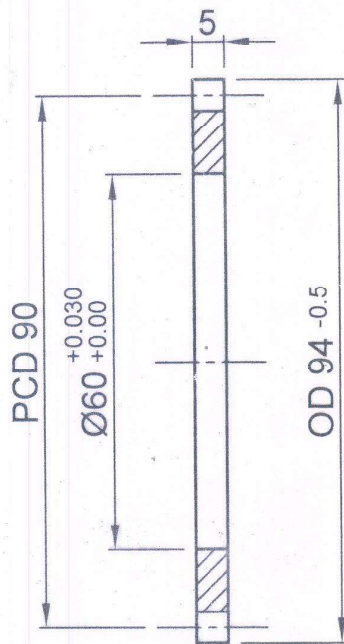

**NOTES**

1. ALL SHARP CORNERS TO BE ROUNDED OFF.
2. DRAWING NO. TO BE PUNCHED AT SUITABLE PLACE.

NO. OF TEETH	45
MODULE	2
MATERIAL	TEXTOLITE

DIMENSIONS TO BE CONTROLLED WITHIN LIMITS AS SHOWN MACHINING TOLERANCE ±0.25mm UNLESS OTHERWISE SHOWN.

FF8251590035

BHARAT HEAVY ELECTRICALS LTD. UNIT: CENTRAL FOUNDRY FORGE PLANT HARDWAR	DRN	T.MANDAL	SIGN	DATE	NO. OF VAR.
	CHD	T.MANDAL		15.03.22	
	APD	KUMAWAT			

DEPT. M&S		SCALE	WEIGHT	REF. TO ASSY. DRG.	ITEM NO.	NO. OF ITEMS
CODE		1:1				73, 74 75, 77

TITLE	DISK (SPUR GEAR)	1	3	DRAWING NO.	04-45-008	0
OF COLUMN GEAR BOX (HEAD STOCK) FOR 1-30 H. BORING MACHINE M/C SHOP				SHEET NO.	01	NO. OF SHEETS 01

SIZE A4

Tender Inviting Authority: CFFP BHEL Haridwar

Name of Work: Spur Gear, Bevel Gears etc

Tender ID: 2022\_BHEL\_12696\_1

Name of the Bidder/ Bidding Firm / Company :	
--	--

PRICE SCHEDULE

(This BOQ template must not be modified/replaced by the bidder and the same should be uploaded after filling the relevant columns, else the bidder is liable to be rejected for this tender. Bidders are allowed to enter the Bidder Name and Values only )

NUMBER #	TEXT #	TEXT #	NUMBER #	TEXT #	TEXT #	NUMBER #	NUMBER	NUMBER	NUMBER	NUMBER	NUMBER	NUMBER	NUMBER	NUMBER #	NUMBER #	NUMBER #	TEXT #
Sl. No.	Item Description	Item Code / Make	Quantity	Units	Quoted Currency in INR / Other Currency	BASIC RATE in Figures To be entered by the Bidder in Rs per unit	PACKING CHARGES if Extra (To be quoted per Unit in Indian Rupees)	Freight (To be quoted per Unit in Indian Rupees if extra)	INSURANCE (To be quoted per Unit in Indian Rupees if extra)	BANK CHARGES (To be quoted per Unit in Indian Rupees if extra)	Other Charges - To be quoted per Unit in Indian Rupees if applicable	GST (If applicable in Percentage)	GST Amount in Rs per unit	HSN / SAC Code	TOTAL AMOUNT excluding taxes	TOTAL AMOUNT including taxes	TOTAL AMOUNT In Words
1	2	3	4	5	12	7	8	9	16	17	20	21	22	10	11	12	13
1.1	DRG: 04-04-013 REV: SPUR GEAR (2ND SHAFT) FOR HEAD STOCK AS PER DRG.	FF8251011019	4.00	Nos.	INR								0.00		0.000	0.000	INR Zero Only
1.2	DRG: 04-04-014 REV: SPUR GEAR (2ND SHAFT) FOR HEAD STOCK AS PER DRG.	FF8251011027	4.00	Nos.	INR								0.00		0.000	0.000	INR Zero Only
1.3	DRG: 04-43-026 R0 REV: BEVEL GEAR AS PER DRG.	FF8251130123	1.00	Nos.	INR								0.00		0.000	0.000	INR Zero Only
1.4	DRG: 04-43-018 R0 REV: BEVEL GEAR AS PER DRG.	FF8251130115	1.00	Nos.	INR								0.00		0.000	0.000	INR Zero Only
1.5	DRG: 04-45-004 R0 REV: SPUR GEAR AS PER DRG.	FF8251590426	1.00	Nos.	INR								0.00		0.000	0.000	INR Zero Only
1.6	DRG: 04-33-011 R1 REV: SPLINE SHAFT FOR COLUMN MOVEMENT AS PER DRG.	FF8251570212	2.00	Nos.	INR								0.00		0.000	0.000	INR Zero Only
1.7	DRG: DRG NO-04.21.002 REV: CARTRIDGE PINION AS PER DRG.	FF8251600111	1.00	Nos.	INR								0.00		0.000	0.000	INR Zero Only
1.8	DRG: 04-21-030 R0 REV: FOURTH SHAFT WITH CHECK NUT AS PER DRG.	FF8251600197	1.00	Nos.	INR								0.00		0.000	0.000	INR Zero Only
1.9	DRG: 06-13-013 REV: SPUR GEAR WITH SPLINE BORE FOR FEED BOX FOR HMT MILLING MAC HINE FN 2U AS PER DRAWING.	FF8251010616	1.00	Nos.	INR								0.00		0.000	0.000	INR Zero Only
2	DRG: 06-01-005 REV: SPUR GEAR AS PER DRAWING.	FF8251520835	1.00	Nos.	INR								0.00		0.000	0.000	INR Zero Only
2.1	DRG: DRG NO. 04-06-074 REV: SPUR GEAR OF RIGHT HEAD FOR VTB 2.5C	FF8251530172	2.00	Nos.	INR								0.00		0.000	0.000	INR Zero Only
2.2	DRG: 04-06-079 REV: BEVEL GEAR FOR FEED SHAFT GEAR BOX VTB 2.5 DRG NO. 04-06-079	FF8251530016	2.00	Nos.	INR								0.00		0.000	0.000	INR Zero Only
2.3	DRG: 04-06-080 REV: BEVEL PINION SHAFT OF FEED SHAFT GEAR BOX VTB 2.5 DRG. NO 04-06-080	FF8251530024	2.00	Nos.	INR								0.00		0.000	0.000	INR Zero Only
2.4	DRG: 04-06-081 REV: SPUR PINION OF LHS GEAR BOX VTB 2.5 DRG NO. 04-06-081	FF8251530032	2.00	Nos.	INR								0.00		0.000	0.000	INR Zero Only
2.5	DRG: 04-06-082 REV: SPUR GEAR OF LHS GEAR BOX VTB 2.5 DRG NO. 04-06-082	FF8251530040	2.00	Nos.	INR								0.00		0.000	0.000	INR Zero Only
2.6	DRG: 04-45-008 REV: DISK (SPUR GEAR) OF COLUMN GEAR BOX HB 1-30 DRG. NO. 04-45-008	FF8251590035	2.00	Nos.	INR								0.00		0.000	0.000	INR Zero Only
<b>Total in Figures</b>															<b>0.000</b>	<b>0.000</b>	INR Zero Only
<b>Quoted Rate in Words</b>															<b>INR Zero Only</b>		





# BHARAT HEAVY ELECTRICALS LIMITED

CFFP-HARIDWAR, UTTARAKHAND (249403)

General Instructions and Standard Terms & Conditions for bidding against Tender Enquiry (GISTC)

For Indian Bidders (Version February-2022, Rev: 08)

## Table of Contents

1. GENERAL .....	1
2. ORIGIN OF QUOTATION .....	1
3. SUBMISSION OF TENDER .....	1
4. TENDER OPENING .....	2
5. SPECIFICATION, DRAWINGS & STANDARD .....	2
6. PRICE SCHEDULE .....	3
7. REVERSE AUCTION .....	3
8. DELIVERY TERMS .....	3
9. LD FOR LATE DELIVERY .....	3
10. PAYMENT TERMS .....	4
11. TAXES & DUTIES .....	5
12. BANK GUARANTEE .....	6
13. GUARANTEE / WARRANTY AND CORRESPONDING REPAIRS / REPLACEMENT OF GOODS .....	6
14. QUALITY REQUIREMENT .....	6
15. VALIDITY .....	6
16. RIGHT OF ACCEPTANCE .....	6
17. TRANSIT INSURANCE .....	7
18. RISK PURCHASE .....	7
19. FORCE MAJEURE CLAUSE .....	7
20. NON-DISCLOSURE AGREEMENT .....	8
21. SETTLEMENT OF DISPUTES / ARBITRATION .....	8
22. WHARFAGE / DEMURRAGE RESPONSIBILITY .....	9
23. CONDITIONS FOR AVAILING MICRO & SMALL ENTERPRISES (MSE'S) BENEFITS .....	9
24. INFORMATION TO THE BIDDERS .....	10
25. MAKE IN INDIA (GOVT-NOTIFICATION) .....	10
26. RESTRICTIONS UNDER RULE 144(XI) OF THE GENERAL FINANCIAL RULES (GFRs), 2017 .....	12
27. NOTE .....	12

## 1. GENERAL.

These general terms & conditions shall apply to all the Tender Enquiries, notice inviting tenders, request for quotations concerning the supply of goods and / or rendering of services to Bharat Heavy Electricals Ltd., CFFP, Haridwar (hereinafter referred to as BHEL or the Purchaser). In case of placement of order these conditions will become part of Purchase Order (P.O) until unless the deviations are specifically agreed by BHEL.

## 2. ORIGIN OF QUOTATION.

- The quotation should preferably be from the principal bidder. However tender specific authorized registered dealer/agent can also submit the bid on their behalf, failing which the quotation is liable to be ignored. BHEL prefers to deal directly with the principal manufacturers.
- An agent cannot quote on behalf of more than one principal in the same Tender Enquiry.

## 3. SUBMISSION OF TENDER.

- Bid / Quotation must be enclosed in sealed cover on which tender enquiry number and the due date MUST BE written and be invariably sent under REGISTERED POST / SPEED POST / COURIER / Dropped in the Tender Box: addressed as follows:

Quotation against Enquiry No. \_\_\_\_\_

Dated: \_\_\_\_\_

Due on: \_\_\_\_\_

To,

**THE HEAD OF MATERIALS MANAGEMENT,  
Central Foundry Forge Plant,  
Bharat Heavy Electricals Limited,  
HARIDWAR-249403 (Uttarakhand), INDIA.**

- TENDER ROOM is located at: Sub-Contracting Building, Near Main Admin. Building, BHEL-CFFP, Haridwar.



## BHARAT HEAVY ELECTRICALS LIMITED

CFFP-HARIDWAR, UTTARAKHAND (249403)

General Instructions and Standard Terms & Conditions for bidding against Tender Enquiry (GISTC)  
For Indian Bidders (Version February-2022, Rev: 08)

- c) In case of Three / Two Part Bid, technical bid containing technical offer, duly signed and un-priced copy of the Price Bid should be kept in one envelope. Price Bid containing only the price should be kept in a separate envelope. All envelopes indicating Part-1 or Part-2 or Part-3 as the case may be to be put in a bigger envelope. Please note that un-priced bid should be the exact replica of price bid but without prices.
- d) The bid / quotation must be posted before due date, keeping allowance for postal transit time. Quotations sent by any mode but not received in time will be ignored. Tender received through authorized E-mail is also acceptable. However, in time submission of tender in tender box shall be the responsibility of the bidder, sent through any mode. Documents submitted with the offer / bid shall be signed and stamped in each page by authorized representative of the bidder.
- e) Any additional documents submitted by supplier / bidder, during processing of registration application / tender or after placement of order shall not be accepted unless it is submitted with forwarding letter and duly signed and stamped.
- f) The bids of the bidders who are on the banned list and also the bids of the bidders, who engage the services of the banned firms, shall be rejected. The cutting / overwriting in the bid / offer must be duly attested by the signatories to the bid. The list of firms banned by BHEL is available on BHEL web site [www.bhel.com](http://www.bhel.com).
- g) Being PMD vendor, if you are not quoting against this tender enquiry, please send your regret letter positively for our reference with valid reasons for not participating in the tender enquiry. Repeated lack of response on the part of bidder may lead to deletion such PMD vendor from BHEL's approved vendor list.
- h) The bidders will submit Integrity Pact, duly signed by its authorized signatory, along with their bids wherever estimated tender value is Rs. 2 Crore or more.
- i) In case of open tender, technically qualified unregistered bidders may apply online for registration through <http://www.bhel.com/index.php/vender>.
- j) BHEL reserves the right to award tendered quantities among more than one bidder (after acceptance of L1 price by the other bidders). BHEL can also consider awarding of part of the tendered quantity to other than L-1 bidder at L1 counter offered rates, if the quantity offered by the L-1 bidder is less than the quantity tendered for.
- k) In case of e-Tendering (Online bidding through e-portal), offline bid submitted in hard copy or in any other form by the vendor / supplier will not be accepted and will be rejected out rightly. Only e-portal bid will be accepted.
- 4. TENDER OPENING.**
- Tender opening is scheduled to start in the Tender Room at 2:00 PM, on the due date. Therefore, bid / quotations must reach this office / tender Box latest by 1:45 PM on due date. Only participating bidders are allowed to attend tender opening. **TENDERS RECEIVED AFTER THE SPECIFIED TIME OF THEIR 'SUBMISSION' WILL BE TREATED AS LATE TENDERS AND SHALL NOT BE CONSIDERED UNDER ANY CIRCUMSTANCES.** The bidders or their authorized representatives may be allowed to attend tender opening if duly authorized by their principals, through a tender specific letter on that particular day. General authorization letter is not acceptable.
- Note: - Foreign bidders willing to attend the bid opening has to provide the requisite documents to the concerned Purchase executives for arranging gate pass for them.***
- 5. SPECIFICATION, DRAWINGS & STANDARD.**
- a) Bidders must give their detailed specification in the quotation along with relevant technical literature / catalogue etc. against the tender enquiry.
- b) The Bid should be accompanied with relevant copies of catalogues, drawings or specification as per tender enquiry. If these documents are not furnished, the offer is liable to be rejected.
- c) Wherever national / international (N/IN) standards are referred, the latest N/IN standards are to be followed.



## BHARAT HEAVY ELECTRICALS LIMITED

CFFP-HARIDWAR, UTTARAKHAND (249403)

**General Instructions and Standard Terms & Conditions for bidding against Tender Enquiry (GISTC)  
For Indian Bidders (Version February-2022, Rev: 08)**

Mention year & date of standard revision that shall be followed for the supply.

- d) All Drawings and Standards are proprietary of BHEL. It must not be used in anyway detrimental to the interest of BHEL or without permission of BHEL.

### 6. PRICE SCHEDULE.

- a) Kindly quote your prices in figures and words both. In case of any discrepancy in value, the prices quoted in words shall be considered for evaluation and establishing L1 status.
- b) Prices quoted should not be more than the prices quoted to any other BHEL units / offices / divisions. Vendor to submit copy of latest Purchase Order placed by any unit of BHEL for similar items in the technical bid. In case no order has been placed on such items, specific confirmation that no order has been placed on such items should be provided.
- c) Prices should be quoted on F.O.R. Destination basis. The offers quoted on other than F.O.R destination basis may result in non-consideration of such bids.
- d) In case BHEL accepts the EX-Works prices, such offers will be loaded by 1.5% of EX-Works value towards freight or with actual freight charges as per BHEL freight rate contract whichever is higher.
- e) In case of Indigenous items covered by DGS & D Rate Contract, the bidders should submit latest valid copy of the rate contract along with bid / quotation
- f) Applicable **IGST / CGST / SGST** and any other statutory levy should be indicated separately and clearly in the bid / quotation.
- g) Bidders can dispatch goods through any Indian Bank Association approved transporters having their branch at HARIDWAR / destination. If material is dispatched through other than Indian Bank Association approved transporter, material to be delivered on door delivery BHEL Stores basis.
- h) In case of dispatch of material through any other unapproved transporter, payment shall be made only after receipt of

material and any additional charges payable to the transporter shall be to the bidder's account.

- i) Any demurrage / godown rent payable to the transporter / or to godown's owner due to any delay attributed by the supplier shall be recovered from supplier's account.
- j) Currency of Evaluation shall be INR.

**NB: Financial evaluation of L1, L2 .....Status will be on the basis of Landed Cost to BHEL.**

### 7. REVERSE AUCTION.

**Wherever RA is declared in the special terms and conditions of tender enquiry, following shall be applicable and Bidders to confirm the same:**

"BHEL shall be resorting to Reverse Auction (RA) (Guidelines as available on [www.bhel.com](http://www.bhel.com)) for this tender. RA shall be conducted among all the techno-commercially qualified bidders.

Price bids of all techno-commercially qualified bidders shall be opened and same shall be considered as initial bids of bidders in RA. In case any bidder(s) do(es) not participate in online Reverse Auction, their sealed envelope price bid along with applicable loading, if any, shall be considered for ranking."

### 8. DELIVERY TERMS.

- a) Goods shall be delivered on 'FOR Destination' basis to the named destination unless otherwise called for in the tender enquiry.

### 9. LIQUIDATED DAMAGES (LD) FOR LATE DELIVERY.

#### a) Where items of Purchase Order are independently usable.

Liquidated Damages (LD) for Late Deliveries shall be applicable @0.5% per week or part thereof on the value of respective delayed supplies subject to a maximum of 10% of the value of respective delayed supplies. Value of delayed supplies will mean the Gross Value payable to the vendor (Before LD) against such supplies excluding taxes and duties.





# BHARAT HEAVY ELECTRICALS LIMITED

CFFP-HARIDWAR, UTTARAKHAND (249403)

General Instructions and Standard Terms & Conditions for bidding against Tender Enquiry (GISTC)

For Indian Bidders (Version February-2022, Rev: 08)

**b) Where the total items are required for a main equipment and items are interdependent.**

Liquidated Damages (LD) for Late Deliveries shall be applicable @0.5% per week or part thereof on total value of Purchase Order subject to maximum of 10% of the total value of Purchase Order. Purchase Order value for this purpose shall be the Total Gross Value payable to the vendor (Before LD) excluding taxes and duties.

c) Bidders are requested to quote the best delivery meeting the delivery requirements. BHEL reserves the right to reject the offers not meeting BHEL's delivery requirement.

d) Commencement of delivery period shall be reckoned from the date of PO / LOI or any other agreed milestone.

e) Bidder shall deliver the goods in the manner and schedule agreed under the terms and conditions of Purchase order.

f) **DELIVERY IN CASE OF REJECTION:** In case the material is rejected, then date of replacement will be considered as the actual date of delivery.

g) **DELIVERY AGAINST BANK DOCUMENTS:** In case payment terms quoted by bidder are documents through bank, and the delivery terms being "FOR Haridwar / FOR Transporter Go-down" then date of delivery will be date of intimation by transporter / bidder of delivery of material at Haridwar for the LD purpose.

h) Where the payments are through bank, the documents may be presented for negotiation to BHEL authorized / nominated bank.

i) Payment of Liquidated Damages (LD) shall not in any way relieve the vendor from any of its obligations & liabilities under the contract.

h) Loading shall be done for not agreed portion (%) of LD in Landed cost calculation.

**10. PAYMENT TERMS.**

a) BHEL's standard payment term is Payment after receipt and acceptance of materials / items at CFFP, BHEL-Store or at desired destination unless otherwise specified in Special Terms attached to the tender enquiry.

b) BHEL reserves the right to accept or reject the offer of the bidder who quotes the payment term other than BHEL's standard payment term.

c) Loading on account of deviation in payment terms shall be done as per extant rules of BHEL-Haridwar.

d) 100% payment along with taxes, freight & insurance will be made after receipt and acceptance of material and within 45 days from the date of invoice subject to submission of non-discrepant documents within 15 days of supply as per terms and conditions of Purchase Order. In case any discrepancy found in the documents, BHEL will notify the same to vendor within 7 days of receipt. Vendor has to clear all the discrepancies in one go within 7 days thereafter else the payment of vendor may get delayed.

e) For MSEs (covered under MSME Act) which are registered and periodically renewed with BHEL, the payment will be made within 45 days or as prescribed in the relevant act.

f) Adherence to the above time schedule of payment is contingent upon Vendor complying with GST Rules w.r.t availment of Input Tax Credit by BHEL.

g) In case GST credit is delayed / denied to BHEL, due to non / delayed receipt of goods and / or tax invoice or expiry of the timeline prescribed in GST Law for availing such ITC, or any other reason not attributable to BHEL, GST amount shall be recoverable from Vendor along with interest levied / leviable on BHEL.

h) The taxes and duties that are reimbursed would be the ones applicable as on the contractual Purchase order delivery date or the amount actually paid whichever is less.

**i) The loading criteria for the different payment terms shall be as under:**

Payment Terms	Days of Loading
After Receipt & Acceptance of material within 45 days of supply.	<b>No Loading</b>
Against Delivery at BHEL-Stores Haridwar.	<b>45</b>
Against documents through bank (CAD):	<b>45</b>
Letter of Credit (LC)	<b>120</b>
No Loading if usance period is > 120 Days.	



## BHARAT HEAVY ELECTRICALS LIMITED

CFFP-HARIDWAR, UTTARAKHAND (249403)

General Instructions and Standard Terms & Conditions for bidding against Tender Enquiry (GISTC)

For Indian Bidders (Version February-2022, Rev: 08)

Usance LC	Loading of days' difference i.e. difference between 120 days and usance period if the usance period is < 45 days.
Advance	Delivery Period + 120 Days - Advance Payment Days.

j) Loading on account of deviation in payment terms shall be done as per extant rules of BHEL-Haridwar. The normal loading shall be @Base rate of SBI (as applicable on the date of bid opening, Techno-commercial bid opening in case of two part bids) + 6%, for the period of relaxation sought by bidders.

### 11. TAXES & DUTIES.

- The bidder to specify in their offer (part 1 bid) the category of their registration under GST like Registered, Unregistered and composite dealer.
- The GST registration number of Bharat Heavy Electrical Ltd, Heavy Electricals Equipment Plant, Ranipur, Haridwar is "05AAACB4146P1ZL" with state Code as "05" and State Name as "Uttarakhand".
- Please quote our GST registration number in all invoices raised for supply of goods and services under GST regime and also ensure filing of timely return and payment of tax and compliance of other applicable provisions on supplier under GST regime.
- No GST will be reimbursed to unregistered or composite dealer. In the event, any GST is quoted by composite dealer, the same shall be added to the cost of supply in evaluating the bid.
- Since, input credit of GST will be available to BHEL-Haridwar only after correct filing of return and payment of applicable GST by supplier, reimbursement of GST shall be made by BHEL-Haridwar on matching of vendor inputs at GST portal, ensuring availability of input credit to BHEL Haridwar. Payment of GST will be made to vendor after matching of input credit and vendor to ensure submission of their invoices along with consent to accept payment of tax after such matching in all cases where bills are submitted directly to BHEL-Haridwar or through bank or under LC or through any other mode.

- GST-TDS as applicable shall be deducted & GST on LD shall also be recovered
- In the event of any disallowance of input credit or applicability of interest or any other financial liability arises on BHEL-Haridwar due to any default of supplier under GST, such implication shall be to supplier's account.
- In the event of any change in the status of the vendor after the submission of the bid but before the supply, GST applicable at the time of supply or in the bid, based on the registration status of the vendor, whichever is lower shall be payable.
- Where ever applicable If PAN (Permanent Account Number) of the recipient is not available, income tax is deductible either at the normal rate or at the rate of 20 percent, whichever is higher as per Section 206AA of Indian Income Tax Act 1961.
- The bidder shall clearly indicate HSN (*Harmonised System Nomenclature*) / SAC (*Service Accounting Code*), its description and applicable rate of GST for each item in his techno-commercial bid.
- Statutory Variation in Taxes & duties as applicable at the time of supply shall be payable. However, in the event of no change in law but bidder quoting certain tax structure in bid document which is lower than the applicable one, such amount shall be the maximum amount of tax that can be claimed by bidder.
- IMPORTED GOODS OFFERED BY INDIAN BIDDERS AGAINST DEALER INVOICE:** Wherever the material being offered is imported, the bidder must quote the prices inclusive of IGST. The rate and value of IGST as included in the price must be indicated separately. In case quantum of IGST is not mentioned by the bidder the same will not be considered for evaluation. However, bidder will have to pass on the benefit of IGST to BHEL at the time supply.
- In case of directly dispatchable items to Customer's Site, BHEL-Haridwar will inform the GST registration number of the respective customer which must be mentioned on the vendor's invoice. Vendor to ensure availability of such information from BHEL-Haridwar before dispatch of any



## BHARAT HEAVY ELECTRICALS LIMITED

CFFP-HARIDWAR, UTTARAKHAND (249403)

General Instructions and Standard Terms & Conditions for bidding against Tender Enquiry (GISTIC)  
For Indian Bidders (Version February-2022, Rev: 08)

material. However, while filing GSTN-1, BHEL Haridwar GSTN number to be quoted.

Note: - Vendors must ensure compliance of all the applicable rules and procedure as envisaged in the GST Regime. Any loss to BHEL-Haridwar due to fault / non-compliance by the vendor will be to the vendor's account.

### 12. BANK GUARANTEE.

In case the bank guarantees are required to be deposited towards security deposit/performance guarantee or for any other purpose as per the terms of this tender enquiry, such bank guarantees of the requisite value in the denominated currency of the purchase order should be from one of the Indian branch of BHEL consortium banks and the bank guarantee should be in the proforma as prescribed by BHEL. The proforma of bank guarantee and the list of consortium banks are displayed at BHEL website www.bhelhwr.co.in. However, in case the bank guarantee is not from BHEL consortium banks, then the bidder has to get the bank guarantee confirmed from one of the Indian branch of BHEL consortium banks and the bank charges for such confirmation will be borne by the bidder.

### 13. GUARANTEE / WARRANTY AND CORRESPONDING REPAIRS / REPLACEMENT OF GOODS.

Goods shall comply with the specifications for material, workmanship and performance. Unless otherwise specified, the warranty shall be for a period of 18 months from the date of receipt. If the delivery is found non-compliant during the warranty period, leading to rejection, the Seller shall arrange free replacement / repair of goods, within one month from the date of intimation or any mutually agreed period. The rejected goods shall be taken away by the Seller at his cost and replaced on Delivered Duty Paid (DDP) (FOR - BHEL Stores / designated destination basis) within such period. In the event of the Seller's failure to comply, Purchaser may take action as appropriate, including Repair / Replenish rejected goods & disposal of rejections, at the risk & cost of the Seller. In case the defects attributable to Seller are detected during processing of the goods at BHEL or at our subcontractor's works, the Seller shall be responsible for free replacement / repair of the goods as required by BHEL.

### 14. QUALITY REQUIREMENT.

Your bid / quotation should have specific confirmation regarding meeting all our quality requirements such as. (i) Test Certificate (TC), (ii) Guarantee Certificate (GC) / Warranty Certificate (WC), (iii) Quality Plan (QP) (if applicable); and (iv) Pre-Dispatch Inspection at your works (if applicable).

### 15. VALIDITY.

The quotation should be valid for a minimum period of 90 days effective from the date of opening of tender, unless otherwise specified in the tender enquiry.

### 16. RIGHT OF ACCEPTANCE.

- a) **BHARAT HEAVY ELECTRICALS LIMITED HARIDWAR** reserves the right to reject any or all the bids / quotations without assigning any reason thereof. BHEL also reserves the right to increase or decrease the tendered quantities. Bidders should be prepared to accept order for reduced quantity without any extra charges.
- b) Any discount / revised offer / bids submitted by a bidder on its own shall be considered, provided it is received on or before the due date and time of offer / bid submission (Part-1). Conditional discounts shall not be considered for evaluation of tenders.
- c) Unsolicited discounts / revised offers / bids given after Part-1 bid opening shall not be accepted. No change in price will be permitted within the validity period asked for in the tender enquiry.
- d) In case of changes in scope and / or technical specification and / or commercial terms & conditions having price implication, techno-commercially acceptable bidders shall be asked by BHEL to submit the impact of such changes on their price bids. In case a bidder opts to submit revised price bid instead of impact called for then the latest price bid shall prevail.



## BHARAT HEAVY ELECTRICALS LIMITED

CFFP-HARIDWAR, UTTARAKHAND (249403)

General Instructions and Standard Terms & Conditions for bidding against Tender Enquiry (GISTC)

For Indian Bidders (Version February-2022, Rev: 08)

However, in both situations, original price bid will be necessarily opened.

- e) The bidder whose bid is technically not accepted will be informed & EMD wherever submitted shall be returned after finalization of contract. EMD shall be forfeited in the event of bidder opting out after tender opening.
- f) BHEL reserves the right to short close the existing Purchase Order / Rate Contract / Work Order or any extension thereof at any stage.

### 17. TRANSIT INSURANCE

- a) All bidders are requested to quote their prices on FOR destination basis. Destination shall be Central Stores, C.F.F.P., BHEL Ranipur, Haridwar. Quoted price shall be inclusive of transit insurance.
- b) In case bidder has submitted their offer without confirmation to transit insurance to their account in their offer, BHEL will load their offer at the applicable rate at that time.

### 18. RISK PURCHASE.

In case of abnormal delays (beyond the maximum late delivery period as per LD clause) in supplies / defective supplies or non-fulfillment of any other terms and conditions given in Purchase Order, BHEL may cancel the Purchase Order in full or part thereof, and may also make the purchase of such material from elsewhere / alternative source at the risk and cost of the supplier. BHEL will take all reasonable steps to get the material from alternate source at optimum cost. If bidder does not agree to the above Risk Purchase Clause, BHEL reserves the right to reject the offer. In case for compelling reasons BHEL accepts the offer without acceptance of this clause by the bidder and in the eventuality of Risk Purchase, appropriate action will be taken as per BHEL extant rules. This will be without prejudice to any other right of BHEL under the contract or under General Law.

### 19. FORCE MAJEURE CLAUSE.

Notwithstanding any other thing contained anywhere else in the contract or PO (Purchase Order), In case the discharge of obligation under the contract by either party is impeded or made unreasonably onerous, neither party shall be considered in breach of the contract to the extent that performance of their respective obligation is prevented by an event of Force Majeure that arises after the effective date (PO date).

In the above clause, Force Majeure means an event beyond the control of the parties to the contract which prevents a party from complying with any obligation of the contract including but not limited to:

- a) Act of God (Such as but not limited to earthquake, drought, tidal waves, floods etc.).
- b) War (whether war be declared or not), Hostilities Invasion, Act of foreign enemy etc.
- c) Rebellion, revolution, insurrection, civil war etc.
- d) Contamination of Radio Activity from any nuclear fuel or from any other nuclear waste or any other hazardous materials.
- e) Riots, commotions, strike unless restricted to the employees of supplier.
- f) Acts of terrorism.
- g) Other unforeseeable circumstances beyond the control of the parties and which the affected party cannot avoid even by using its best efforts.
- h) Cancellation of contract by customer.
- i) Change in law / government. Regulation making the performance impossible.
- j) Pandemic or Epidemic.

The party claiming to be affected by force majeure shall notify the other party in writing immediately without delay on the intervention and on the cessation of such circumstances.

Irrespective of any extension of time, if an event of force majeure occurs and its effect continues for more than 180 days the affected party shall have right to cancel the contract.

As soon as reasonably practicable following the date of commencement of a Force Majeure Event, and within a reasonable time following the date of termination of a Force Majeure Event, either Party invoking it shall submit to the other Party reasonable proof of the nature of the Force Majeure Event and of its effect upon the performance of the Party's obligations under this Agreement.



**BHARAT HEAVY ELECTRICALS LIMITED**

CFFP-HARIDWAR, UTTARAKHAND (249403)

**General Instructions and Standard Terms & Conditions for bidding against Tender Enquiry (GISTC)**

**For Indian Bidders (Version February-2022, Rev: 08)**

The party shall, and shall ensure that its Subcontractors shall, at all times take all reasonable steps within their respective powers and consistent with Good Operating Practices (but without incurring unreasonable additional costs) to:

- a) Prevent Force Majeure Events affecting the performance of the party's obligations under this Agreement.
- b) mitigate the effect of any Force Majeure Event and
- c) Comply with its obligations under this Agreement.

If the war like situation has developed in a country where a seller's works is located in this P.O. or there is political instability and Indian Embassy located in that country forbids or advises for not having any business dealing with the sellers located in such zone / region/ country, then BHEL reserves the right to cancel the order.

**20. NON-DISCLOSURE AGREEMENT.**

All Drawing and Technical Documents relating to the product or it's manufacture submitted by one party to the other, prior or subsequent to the formation of contract, shall remain property of the submitting party. Drawing, technical documents or other technical information received by one party, shall not without the consent of the other party, be used for any other purpose than that, for which they were provided. Such technical information shall not without the consent of the submitting party, otherwise be used or copied, reproduced, transmitted or communicated to a third party. Patterns supplied by BHEL will remain BHEL's property which shall be returned by the bidder on demand to BHEL. Bidder shall in no way share or use such intellectual property of BHEL to promote his own business with others or to gain a commercial advantage. BHEL reserves the right to claim damages from the bidder, or take appropriate action as deemed fit against the bidder, for any infringement of the provisions contained herein as available under law or equity.

**21.SETTLEMENT OF DISPUTES / ARBITRATION.**

In case of any dispute arising out of as in connection with this contract, the same shall be referred to arbitration under Arbitration & Conciliation Act 1996 of a sole arbitrator who shall be appointed by mutual consent of the parties. The seat & venue of arbitration shall be Haridwar.

The proceedings shall be conducted in English. The Governing law of contract shall be the substantive law of India.

**MODEL CONCILIATION CLAUSE FOR CONDUCTING CONCILIATION PROCEEDINGS UNDER THE BHEL CONCILIATION SCHEME,2018**

The Parties agree that if at any time (whether before, during or after the arbitral or judicial proceedings), any Disputes (which term shall mean and include any dispute, difference, question or disagreement arising in connection with construction, meaning, operation, effect, interpretation or breach of the agreement, contract or the Memorandum of Understanding (delete whichever is inapplicable), which the Parties are unable to settle mutually), arise inter-se the Parties, the same may, be referred by either party to Conciliation to be conducted through Independent Experts Committee to be appointed by competent authority of BHEL from the BHEL Panel of Conciliators.

Notes:

1. No serving or a retired employee of BHEL/ Administrative Ministry of BHEL shall be included in the BHEL Panel of Conciliators.
2. Any other person(s) can be appointed as Conciliators (s) who is/ are mutually agreeable to other the parties from outside the BHEL Panel of Conciliators.

The proceedings of Conciliation shall broadly be governed by Part-III of the Arbitration and Conciliation Act 1996 or any statutory modification therefore and as provided in Annexure.....to this GCC/ Agreement/Contract/MoU etc. (Strike off whichever is inapplicable).

The Annexure..... together with it's Formats will be treated as if the same is party and parcel hereof and shall be as effectual as if set out herein in this GCC/Agreement/Contract/MoU etc. (strike off whichever is inapplicable).

The Purchaser/Contractor/Seller etc. (insert the description of the other party to the Agreement/Contract/MoU etc.,- whichever is applicable) agrees that the Purchaser/Contractor /Seller etc. (insert the description of BHEL –whichever is applicable) may make any amendments or modifications to the provisions stipulated in the Annexure.....to this GCC/Agreement/Contract/MoU etc., (strike off whichever is inapplicable) from time to time and confirms that it shall be





## BHARAT HEAVY ELECTRICALS LIMITED

CFFP-HARIDWAR, UTTARAKHAND (249403)

General Instructions and Standard Terms & Conditions for bidding against Tender Enquiry (GISTC)

For Indian Bidders (Version February-2022, Rev: 08)

bound by such amended or modified provisions of the Annexure.....with effect from the date as intimated by BHEL to it.

### 22. WHARFAGE / DEMURRAGE RESPONSIBILITY.

In the event of delay in receipt of documents by Manager (Stores-Shipping) BHEL-Haridwar and in case where dispatches are made through Unapproved Transporter the sole responsibility for wharfage / demurrage for such delay shall be that of supplier.

### 23. CONDITIONS FOR AVAILING MICRO & SMALL ENTERPRISES (MSE'S) BENEFITS.

- a) "MSE Suppliers can avail the intended benefits only if they submit along with the offer, attested copies of either EM II certificate having deemed validity (**five years** from the date of issue of acknowledgement in EM II) or valid NSIC certificate or EM II certificate along with attested copy of a CA certificate (Format enclosed at annexure-1 where deemed validity of EM II certificate of five years has expired) applicable for the relevant financial year (latest audited). Date to be reckoned for determining the deemed validity will be the date of bid opening (Part 1 in case of two-part bid) or vendor has to give Udyog Adhar Memorandum (UAM)/UDYAM. Non submission of such documents will lead to consideration of their bid at par with other bidders. No benefit shall be applicable for this enquiry if any deficiency in the above required documents is found or the requisite documents are not submitted before price bid opening. If the tender is to be submitted through e-procurement portal, then the above require document are to be uploaded on the portal. Documents should be notarized or attested by a Gazetted officer. **UAM/UDYAM need not required to be notarized or attested.**
- b) Any new supplier will be eligible for registration with BHEL as MSE supplier provided at least any one of the following documents are submitted along with application for registration: -
1. Udyog Adhar Memorandum (UAM) /UDYAM.
  2. Valid National Small Industries Commission (NSIC) Certificate.
  3. Entrepreneurs Memorandum part II (EM II) certificate (valid based on deemed validity of 5 years) or

4. EM II certificate along with attested copy of CA Certificate (as per prescribed format at annexure-A) applicable for the relevant financial year (latest audited), where the deemed validity of EM II is over.
5. However, credentials of all MSE suppliers will be verified before advancing the intended benefits.
6. MSE bidders claiming SC/ST status will have to submit SC/ST certificate of the Proprietor from competent authority. Attested (notarized or attested by Gazetted officer) copy to be submitted along with the offer.
7. In case techno-commercial accepted bidders include MSE source and their prices (based on landed cost – considering quoted prices) are within the price band of 15% w.r.t. L-1 bidder, then BHEL can offer **25%** of quantity of respective item (rounded off to nearest number) to MSE bidders at L-1 price and in case, more than one MSE bidder is in 15 % band and the same is accepted by more than one MSE bidders then **25%** quantities of respective items will be considered for ordering on proportionate basis amongst MSE bidders.
8. There will be minimum of **3%** reservation for women owned MSEs within the above mentioned 25% reservation.
9. The reservation for MSEs owned by SC/ST will be **6.25%** { 25% out of target of 25% - refer para 4 of Public Procurement Policy for the Micro and Small Enterprises(MSEs)}.
10. The definition of MSEs owned by Women Entrepreneurs is clarified as under:
  - a) In case of proprietary MSE, proprietor shall be Woman.
  - b) In case of partnership MSE, the Woman partners shall be holding at least 51% of share in the unit.
  - c) In case of Private Limited companies, at least 51% share shall be held by Women promoters.
11. The definition of MSEs owned by SC/ST is clarified as under:
  - a) In case of proprietary MSE, proprietor(s) shall be SC/ST.
  - b) In case of partnership MSE, the SC/ST partners shall be holding at least 51% of shares in the unit.
  - c) In case of Private Limited companies, at least 51% share shall be held by SC/ST promoters.
12. While distributing the **25%** quantity amongst MSE bidders the decimal points in quantity shall be ignored for all the bidders except the L-1 amongst MSE bidders. Balance quantity after allocating the quantity to other MSE bidders ignoring the quantities in decimal, shall be given to L-1 (amongst MSE) bidder. However, if there are more than one MSE bidder at the same price level than preference for additional quantities due to ignoring off the decimal (as mentioned above) shall be

## Quotations / Bids not in accordance with General Instructions and Standard Terms & Conditions are likely to be ignored.



## BHARAT HEAVY ELECTRICALS LIMITED

CFFP-HARIDWAR, UTTARAKHAND (249403)

General Instructions and Standard Terms & Conditions for bidding against Tender Enquiry (GISTC)

For Indian Bidders (Version February-2022, Rev: 08)

given to the bidder offering favorable terms to BHEL and if the conditions offered are also same then preference will be given to the bidder having high SPR rating.

13. In case there are more than one MSE bidders (with different landed cost to BHEL) within 15% price band of lowest bidder and quantity to be offered is 1 no. only, then preference shall be given to the MSE bidder with lowest landed cost.
14. In case there are more than one MSE bidders (with same landed cost to BHEL) within 15% price band of lowest bidder and quantity to be offered is 1 no. only, then preference shall be given first, based on the favorable terms in the bid and in case terms are also same, the bidder with high SPR rating shall be given preference.
15. If L1 bidder is MSE bidder, entire quantity will be given to such MSE bidder only.
16. Note: It may however be noted that MSE guidelines as on date (Date of Technical Bid Opening Part-1) shall prevail.
17. "As per the OM No. F.No. 1(2)(1)/2016-MA dtd. 09.02.2017 issued from the Office of Development Commissioner (Micro, Small & Medium Enterprises), "Traders and agents should not be allowed to avail the benefits extended under the PP Policy."

In view of this, it is clarified that benefits of MSE (such as EMD Waiver, Tender fee exemption, Price preference, Payment preference etc.) will be given only to those MSE Vendors who are manufacturers of offered items against the NIT. No MSE benefits shall be provided to Agents / Stockists / Dealers / Traders etc. for the items offered but not manufactured by themselves."

#### 24. INFORMATION TO THE BIDDERS.

- a) Purchase related information is available at our Business-to-Business (B2B) Portal available on our website <https://hwr.bhel.com>. The user ID & password can be obtained by sending a request to concerned purchase executives.
- b) Intimate your change in mail address or communication address or changes, if any, by email to Head (Purchase) giving your bidder Code.
- c) Please resolve your rejections and unexecuted overdue purchase order immediately which are posted at our B2B

Portal, which can be visited through our site <https://hwr.bhel.com>

- d) Copy of this Tender Enquiry is being sent through the post.
- e) The Bidder declares that they will not enter into any illegal or undisclosed agreement or understanding, whether formal or informal with other bidder(s). This applies in particular to prices, specifications, certifications, subsidiary contracts, submission or non-submission of bids or any other actions to restrict competitiveness or to introduce cartelization in the bidding process.  
In case, the bidder is found having indulged in above activities, suitable action shall be taken by BHEL as per extant policies/guidelines.
- f) Supplier must upload digitally signed e-Invoice on B2B portal for processing of Bills.  
In other cases, inked signed hard copy of Invoice to be submitted for processing of Bills.

#### 25. MAKE IN INDIA (GOVT-NOTIFICATION).

- A. This tender enquiry shall be governed by notification no. P-45021/2/2017-PP (BE-II) dated 04.06.2020 of government of INDIA and subsequent circulars issued afterwards. Accordingly, the minimum local content, the margin of purchase preference and the procedure for preference to make in INDIA shall be adhered.
- B. The margin of purchase preference shall be 20%.
  - 'Class-I local Supplier' means a supplier or service provider, whose goods, services or works offered for procurement, has local content equal to or more than 50%, as defined under this order.
  - 'Class-II local Supplier' means a supplier or service provider, whose goods, services or works offered for procurement, has local content more than 20% but less than 50%, as defined under this order.
  - 'Non- local Supplier' means a supplier or service provider, whose goods, services or works offered for procurement, has local content less than or equal to 20%, as defined under this order.
- C. Vendor to specifically confirm if they are Class-I or Class-II local supplier or not as per above mentioned notification. Accordingly, the 'Class-I local supplier' / 'Class-II local Supplier' at the time of tender, bidding or solicitation shall be

## Quotations / Bids not in accordance with General Instructions and Standard Terms & Conditions are likely to be ignored.



## BHARAT HEAVY ELECTRICALS LIMITED

CFFP-HARIDWAR, UTTARAKHAND (249403)

General Instructions and Standard Terms & Conditions for bidding against Tender Enquiry (GISTC)

For Indian Bidders (Version February-2022, Rev: 08)

required to indicate percentage of local content and provide self-certification that the item offered meets the local content requirement for 'Class-I local supplier' / 'Class-II local Supplier', as the case may be. They shall also give details of the location(s) at which the local value addition is made.

D. In cases of Procurement for a Value in Excess of Rs. 10 Crores, the 'Class-I local supplier' / 'Class-II local Supplier' shall be required to provide a Certificate from the Statutory Auditor or Cost Auditor of the Company (in the case of companies) or from a practicing Cost Accountant or practicing Chartered Accountant (in respect of suppliers other than companies) giving the percentage of Local Content.

E. Requirement of Purchase Preference:

Purchase preference shall be given to 'Class-I local supplier' in procurements undertaken by procuring entities in the manner specified hereunder -

a. In the procurements of goods or works, which are covered by para 3(b) of mentioned Govt. circular and which are divisible in nature, the 'class-I local supplier' shall get purchase preference over 'Class-II supplier' as well as 'Non-local supplier', as per following procedure:

- i. Among All qualified bids, the lowest bid will be termed as L1. If L1 is 'Class-I local supplier', the contract for full quantity will be awarded to L1.
- ii. If L1 bid is not a 'Class-I local supplier', 50% of the order quantity shall be awarded to L1. Thereafter, the lowest bidder among the 'Class-I local supplier' will be invited to match the L1 price for the remaining 50% quantity subject to the class-I local supplier's quoted price falling within the margin of purchase preference, and contract for that quantity shall be awarded to such 'Class-I local supplier' subject to matching the L1 price. In case such lowest eligible 'Class-I local supplier' fails to match the L1 price or accepts less than the offered quantity, the next higher 'Class-I local supplier' within the margin of purchase preference shall be invited to match the L1 price for remaining quantity and so on, and contract shall be awarded accordingly. In case some quantity is still left uncovered on Class-I local supplier, then such balance quantity may also be ordered on the L1 bidder".

b. In the procurements of goods or works, which are covered by para 3(b) of mentioned Govt. circular and

which are not divisible in nature, and in procurement of services where the bid is evaluated on price alone, the 'class-I local supplier' shall get purchase preference over 'Class-II supplier' as well as 'Non-local supplier', as per following procedure:

- i. Among all qualified bids, the lowest bid will be termed as L1. If L1 is 'Class-I local supplier', the contract will be awarded to L1.
- ii. If L1 is not 'Class-I local supplier', the lowest bidder among the 'Class-I local supplier', will be invited to match the L1 price subject to Class-I local supplier's quoted price falling within the margin of purchase preference, and the contract shall be awarded to such 'Class-I local supplier' subject to matching the L1 price.
- iii. In case such lowest eligible 'Class-I local supplier', fails to match the L1 price, the 'Class-I local supplier' with the next higher bid within the margin of purchase preference shall be invited to match the L1 price and so on and contract shall be awarded accordingly. In case none of the 'Class-I local supplier' within the margin of purchase preference matches the L1 prices, the contract may be awarded to the L1 bidder.

c. 'Class-II local supplier' will not get purchase preference in any procurement, undertaken by procuring entities.

F. For this procurement, the local content to categorize a supplier as a Class-I local supplier/ Class-II local supplier/ Non-local supplier and purchase preference to Class-I local supplier, is as defined in Public Procurement (Preference to Make in India), Order 2017 dated 04.06.2020 issued by DPIIT. In case of subsequent orders issued by nodal ministry, changing the definition of local content for the items of the NIT, the same shall be applicable even if issued after issue of this NIT, but before opening of Part-II bids against this NIT.

G. Procurements where estimated value to be procured is less than Rs. 5 lakhs shall be exempted from GOI order No. P-45021/2/2017-PP (BE-II) dated 04.06.2020.

H. For procurement of Goods & Services which are divisible in nature, following shall be operated for **MSE bidders** under Public procurement Policy for the Micro and Small Enterprises (MSEs) Amendment Order, 2019, Ref. No. AA:SSP: MSE: Amndt, dtd. 30.11.2018, Circular No. 44 of 2018-19;-





## BHARAT HEAVY ELECTRICALS LIMITED

CFFP-HARIDWAR, UTTARAKHAND (249403)

General Instructions and Standard Terms & Conditions for bidding against Tender Enquiry (GISTC)

For Indian Bidders (Version February-2022, Rev: 08)

- a. If L1 bid is not from "Class-I local Supplier" and price quoted by MSE bidder falls within the margin of Purchase preference (L1+15% for MSEs), then 25 % of total order quantity of respective item (rounded off to nearest number) shall be awarded to MSE bidder, subject to MSE bidder matching the L1 Price. Out of Remaining 75% quantity, distribution shall be operated as per below sub-clause (2) –
- b. If "Class- I Local Supplier" (Next to L1, other than MSE) quoted price falling within the Margin of Purchase Preference, and "Class-I local supplier" matches the L1 price, then 50% of remaining Quantity (after allocation of 25% to MSE) i.e. 37.5% shall be awarded to local supplier and 37.5% shall be awarded to foreign bidder.

*Note: L1 Price refers to lowest evaluated / landed cost to Company.*

For Further details, please refer GOI order no. P-45021 / 2 / 2017 - PP (BE-II) dated 04.06.2020.

### 26. RESTRICTIONS UNDER RULE 144(XI) OF THE GENERAL FINANCIAL RULES (GFRs), 2017

All provisions of Order No. F.No.6/18/2019-PPD of Department of Expenditure (DoE) shall be applicable for this tender enquiry (Order copy is available at <https://doe.gov.in/procurement-policy-divisions>). Accordingly, any bidder from a country which shares a land border with India (except the countries to which the Govt. of India has extended lines of credit or in which the Govt. of India is engaged in development projects for which list is available at <https://www.mea.gov.in/>) will be eligible to bid in this tender only if the bidder is registered with the Competent Authority as specified in Annex I of the said Order of DoE.

Updated list of the countries to which lines of credit have been extended or in which development projects are undertaken are available on the Ministry of External affairs website (<https://www.mea.gov.in/>)

For the purpose of this order, definition of Bidder from a country which shares a land border with India shall be same as defined in the Annex III of the said order.

Registration with the competent authority as stipulated in the said order is responsibility of bidder. Bidder has to submit a certificate certifying following along with offer:

"I have read the clause regarding restrictions on procurement from a bidder of a country which shares a land border with India; I certify that bidder (... Name of Bidder) is not from such a country or, if from such a country, has been registered with the Competent Authority. I hereby certify that bidder (.....Name of bidder) fulfils all requirements in this regard and is eligible to be considered"

If the bidder is from such country which shares a land border with India evidence of valid registration by the Competent Authority shall also be attached along with offer."

### 27. NOTE.

- a) Special conditions of enquiry, if enclosed by BHEL, will supersede the respective standard / general terms of enquiry.
- b) Any other Standard terms and Conditions of the bidder attached / referred against the tender enquiry will be treated as null and void ab initio.
- c) In order to protect the commercial interests of BHEL, it becomes necessary to take action against suppliers / contractors by way of suspension of business dealings, who either fail to perform or are in default without any reasonable cause, cause loss of business / money / reputation, indulged in malpractices, cheating, bribery, fraud or any other misconducts or formation of cartel so as to influence the bidding process or influence the price etc. Guide- lines for Suspension of Business Dealings with Suppliers / Contractors shall prevail over which is available at BHEL website <http://www.bhel.com>
- d) The bidder along with its associate / collaborators / sub-contractors / sub-vendors / consultants / service providers shall strictly adhere to BHEL Fraud Prevention Policy displayed on BHEL website <http://www.bhel.com> and shall immediately bring to the notice of BHEL-Management about any fraud or suspected fraud as soon as it comes to their notice.
- e) "BHEL shall recover the amount of compensation paid to victim(s) by BHEL towards loss of life / permanent disability due to an accident which is attributable to the negligence of contractor, agency or firm or any of its employees as detailed below;

**## Quotations / Bids not in accordance with General Instructions and Standard Terms & Conditions are likely to be ignored.**



## BHARAT HEAVY ELECTRICALS LIMITED

CFFP-HARIDWAR, UTTARAKHAND (249403)

General Instructions and Standard Terms & Conditions for bidding against Tender Enquiry (GISTC)

For Indian Bidders (Version February-2022, Rev: 08)

1. **Victim:** Any person who suffers permanent disablement or dies in an accident as defined below.

2. **Accident:** Any death or permanent disability resulting solely and directly from any unintended and unforeseen injurious occurrence caused during the manufacturing / operation and works incidental thereto at BHEL factories/ **offices and precincts** thereof , project execution , erection and commissioning, services, repairs and maintenance, trouble shooting, serving , overhaul, renovation and retrofitting , trial operation, performance guarantee testing undertaken by the company or during any works / during working at BHEL Units/ Offices/ townships and premises/ project sites.

3. **Compensation in respect of each of the victims:**

(i) In the event of death or **permanent disability** resulting from **Loss of both limbs:** Rs. 10,00,000/- (Rs. Ten Lakh).

(ii) In the event of **other permanent disability:** Rs. 7,00,000/- (Rs. Seven Lakh).

4. **Permanent Disablement:** A disablement that is classified as a permanent total disablement under the proviso to Section 2(l) of the Employees Compensation Act, 1923.”

f) The bidder shall be in compliance with applicable laws, rules and regulations throughout the terms of the contract for conducting its business generally and to perform its obligations under this contract.