



Bharat Heavy Electricals Limited
SOLAR BUSINESS DIVISION
Malleswaram, Bangalore – 560012

Ph. 080-26992289
SC&PV – PVSS- DEPT.

NOTICE INVITING TENDERS

- 1 TENDER NUMBER(RFQ) : EDN: PVSS:GSECL:100MW:PH-II:RD&DRAIN-WT/CIVIL/02 Dt.: 07.08.2021
- 2 NAME OF WORK : **CONSTRUCTION OF ROADS, DRAINS, CULVERT AND 4 Nos. 2.5 LAKH LITRES CAPACITY OF UNDERGROUND RCC WATER TANK FOR 100 MWp SOLAR PV PLANT FOR GSECL, RAGHANESDA PHASE-II**
(All listed works shall be Undertaken and executed)
- 3 ESTIMATED COST : **Rs.816.54 Lakhs (Approx.) Plus applicable GST.**
- 4 EARNEST MONEY DEPOSIT : **Rs.9.60 Lakhs (Mandatory for MSME also)**
(a) Bidders can submit Rs.9.60 Lakhs EMD through DD/SBI Collect
(Please refer page-11 point no.: 20 of “Instructions to tenderer” for guideline for payment through SBI Collect)
(b) Alternatively bidders can submit Rs.2.0 Lakhs EMD through DD/SBI collect and balance Rs.7.60 Lakhs in the form of Bank Guarantee from the scheduled bank as per attached BG format.
- 5 SECURITY DEPOSIT : 50% of SD shall be submitted before start of work; Balance will be recovered from running Bills at a rate of 10%. (SD= 5% of the work order amount); 50% of SD will be released after completion of all the works and remaining 50% after 6 months from the date of completion of all the works.
- 6 COMPLETION TIME : **4 Months** for each work mentioned in page no.5 (From the date of placement of Order/handing over of the site.)
- 7 LAST DATE AND TIME FOR THE SUBMISSION OF DULY FILLED IN TENDER DOCUMENT : 17.08.2021 Before 01:00 P.M
- 8 PALCE OF SUBMISSION OF TENDER DOCUMENT : Smt. S N BHAGYASHREE S N, GM (SC&PV- Engg.)
BHEL- Solar Business Division
CPBG- Control Panel shop-78
Professor C.N.Rao Circle, In-front of IISC
Malleswaram, Bangalore-560012
- 9 ORIGINAL BG/DD FOR EMD SHALL BE SENT THROUGH SPEED POST/COURIER/ANY OTHER AVAILABLE MODE TO : Smt. S N BHAGYASHREE S N, GM (SC&PV- Engg.)
BHEL- Solar Business Division
CPBG- Control Panel shop-78
Professor C.N.Rao Circle, In-front of IISC
Malleswaram, Bangalore-560012
- 10 DATE AND TIME OF TECHNICAL BID OPENING : 17.08.2021 Before 01:30 P.M
- 11 TENDER MONITORING AUTHORITY (IEM) : Mr. Arun Chandra Verma, IPS (Retd.) & Virendra Bahadur Singh IPS (Retd.)

NOTE: The tenderer shall return the dully filled in tender document after affixing signature on all pages and submit.



Bharat Heavy Electricals Ltd
Electronics Division
Malleswaram Bangalore – 560012

Tender Document for

Construction of Roads, Drains, Culvert and 4 Nos. 2.5 Lakh Liters Capacity of Underground RCC Water Tank for 100 MWp Solar PV Plant for GSECL, Raghnesda Phase-II

TENDER NUMBER RFQ: EDN: PVSS:GSECL:100MW:PH-II:RD&DRAIN-WT/CIVIL/02 Dt.: 07.08.2021

TECHNICAL BID DATE OF OPENING: 17-08-2021 (Price bid opening date intimation will be given separately)

Part – I	Technical cum Commercial Bid	41 Pages
	Unpriced Price Bid	05 Pages
	Technical and General Specification	12 Pages
	BHEL General Conditions of Contract 2019	33 Pages
	Tentative Tender Drawing	04 Pages
	Tentative Field Quality Plan	08 Pages
	BHEL Reverse Auction Guidelines	09 Pages
	Integrity Pact	07 Pages
	Annexure to Integrity Pact	01 Pages
	Bank Guarantee format for EMD	02 Pages
Part – II	Price Bid	05 Pages

Note:

1. Part – I: To be submitted in a separate sealed cover.
2. Part – II: To be submitted in a separate sealed cover.
3. Earnest Money Deposit of Rupees **9.60 Lakhs** shall be submitted as per point No. 4 of page No. 1 of this tender document.
4. Tenders will be liable for rejection if the above mentioned EMD is not submitted along with the tender.
5. Part-I, Part-II, Tender EMD sealed covers should be put in outer envelope and super scribing the Name of work and Name & Address of the Tenderer.
6. **Firms banned by BHEL are not eligible to participate in the tender. The tender submitted by such a firms will not be opened for evaluation and no communication in this regard will be entertained.**
7. **Please ensure submission of offer before the due date and time. No other mode of submission is permitted. Late offers will be rejected.**
8. Only those bidders who have entered into Integrity Pact with BHEL would be competent to participate in the bidding. In other words, entering into integrity Pact shall be preliminary qualification. Details of Independent External Monitors (IEM) for this tender is in page No. 1, Sl. No.11



BHARAT HEAVY ELECTRICALS LTD, SOLAR BUISNESS DIVISION, BANGALORE-12

TENDER NUMBER RFQ: EDN: PVSS:GSECL:100MW:PH-II:RD&DRAIN-WT/CIVIL/02 Dt.: 07.08.2021

PART-I TECHNICAL-CUM-COMMERCIAL BID

(To be furnished by the Bidders)

01. NAME OF THE WORK : **“Construction Of Roads, Drains, Culvert and 4 Nos. 2.5 Lakh Litres Capacity of Underground RCC Water Tank for 100 MWp Solar PV Plant for GSECL, Raghnesda Phase-II”**
(All listed works shall be Undertaken and executed)
02. APPROXIMATE ESTT.COST RS. : Rs.816.54 lakhs (APPROX.) plus applicable GST.
03. COMPLETION PERIOD : 4 Months for each work mentioned in page no.5 (From the date of placement of Order/handing over of site.)
04. NAME OF THE CONTRACTOR :
(WITH CONTACT PERSON)
05. ADDRESS
(A) OFFICE :
E-mail :
TEL. PH. NO. :

(B)RESIDENCE :

TEL.PH NO :
06. PAN NO :
07. GST NO :
08. STAFF STRENGTH :
09. PLANT/EQUIPMENTS : List enclosed/not enclosed
10. a) SCOPE OF WORK : UNDERSTOOD/ NOT UNDERSTOOD
(As per schedule of items)
b) Accept to execute in total : YES/ NO
c) Bar chart to be submitted : YES/ NO
Individually for each work for L1 Scope
d) In order to complete the project
in the specified months schedule, vendor
to deploy separate Five gangs/teams (or) more
as per site requirement for each individual activities
along with tools and machineries, Undertaking
should be submitted along with offer : YES/ NO



11. a) EMD PARTICULARS (DEMAND DRAFT/
SBI COLLECT REF NO. / BG DETAIL) :
- b) Electronic Funds Transfer (EFT) form enclosed : Please fill up the form in ANNEXURE-II
12. Penalty as per BHEL General conditions of contract
2019 clause No. 2.7.9 : Accepted / Not accepted
13. Constitution of Firm : Individual / Sole Proprietorship Concern /
Partnership Firm / Public Ltd. Company/
Private Ltd. Company.
14. BHEL reserves right to conduct reverse auction : Accepted / Not accepted
*“BHEL shall be resorting to Reverse Auction (RA)
(Guidelines as available on www.bhel.com) for
this tender. RA shall be conducted among all
the techno-commercially qualified bidders.
Price bids of all techno-commercially qualified
bidders shall be opened and same shall be
considered as initial bids of bidders in RA. In case
any bidder(s) do(es) not participate in online
Reverse Auction, their sealed envelope price bid
along with applicable loading, if any, shall be
considered for ranking.”*
15. Accept to pay statutory payments like ESI, PF,
BOCW, etc., as per terms and conditions of
BHEL and Govt. guideline’s : Accepted / Not accepted
16. BHEL Payment terms acceptance (Cl. no. 21,
22.1 & 22.2 of “Special Conditions of Contract”) : Accepted / Not accepted
17. The bidder should encourage to use local labor
that has the necessary skills as per the
requirement of work. : Accepted / Not accepted
18. Acceptance for Splitting of contract mentioned
on page no.5 of this NIT : Accepted / Not accepted

Note:

1. Bidders are required to visit site and understand the conditions like soil, climate, etc before quoting their price/offer.
2. Bidders are advised to quote their best prices (% above/below the total estimate +/- (or) at par) as no further price bids will be accepted in case BHEL decides to open price bids instead of reverse auction.
3. Successful bidders are required to plan and Execute work during rainy/monsoon season also.
4. In view of the necessity to complete the works as per the schedule and for stringent quality control it is required that works awarded to contractor shall not be sublet by the contractor to any other agency in partial or full, without prior approval of BHEL. All works shall be carried out under the supervision of contractor by placing their regular employees at site.
5. In view of present pandemic situation it is advised to all bidders to mandatorily ensure all precautionary measures as per guidelines issued by State/Central government/District administration to prevent spread of COVID-19 like usage of Personal protective Equipment’s and other norms like wearing masks, maintaining social distance and other instructions issued from time to time.



SCOPE OF WORK:

Works (A) - Estimated value for 60%scope of Construction of Roads, Drains, Culvert & 2 Nos. of UG tank of capacity 2.5Lakh litres **Rs 4,79,20,022 /-** plus GST as applicable.

Works (B) - Estimated value for 40%scope of Construction of Roads, Drains, Culvert & 2 Nos. of UG tank of capacity 2.5Lakh litres **Rs. 3,73,34,062 /-** plus GST as applicable.

SL.NO	Name of Work	DESCRIPTION OF WORK	Amount (in Rs)	Scope of Work
1	WORK-(A)	Work value for 60% scope of Construction Of Roads, Drains, Culvert & 2 Nos. of UG tank of capacity 2.5 Lakh litres	Rs. 4,79,20,022/-	L1 - Scope of Work
2	WORK-(B)	Work value for 40% scope of Construction Of Roads, Drains, Culvert & 2 Nos. of UG tank of capacity 2.5 Lakh litres	Rs. 3,37,34,062/-	L2 - Scope of Work
TOTAL WORK VALUE (A +B)			Rs. 8,16,54,084/-	(Plus Applicable GST)

SPLITTING OF CONTRACT:

In view of large quantum of work, restricted period for completion of project it is proposed to split the work as below:

- L1 and L2 bidder will be awarded Works (A) and Works (B) respectively in such case L2 bidder should match the price of L1.
- In case of denial to accept L1 rates by L2 it shall be offered subsequently to all other bidders till we get one vendors to accept L1 rates for the scope of works (B).
- However in case no bidder agrees to match L1 price , then L1 bidder is bound to execute the scope of work of all (or) BHEL may take a decision to re-float the tender
- However in any case, BHEL reserves the right to change the splitting of the scope of work (or) re-float the tender.



PRE QUALIFICATION CRETERIA

1. Experience of having successfully completed roads and drain work (or) RCC structure/foundations/ during last 7 years from the date of tender notice.
 - a) Three similar completed roads and drain work (or) RCC structure/foundations each costing not less than an amount equal to 40% of NIT displayed value (i.e.191.68 Lakhs) mentioned against each work in the tender notice.

OR
 - b) Two similar completed roads and drain work (or) RCC structure/foundations each costing not less than an amount equal to 50% of NIT displayed value (i.e.239.60 Lakhs) mentioned against each work in the tender notice.

OR
 - c) One similar completed roads and drain work (or) RCC structure/foundations each costing not less than an amount equal to 80% of NIT displayed value (i.e. 383.36 Lakhs) mentioned against each work in the tender notice.

2. Average annual financial turn over during the last 3 years, ending 31st March of the previous financial year, should be 30% of the NIT displayed value (i.e.143.76 Lakhs) mentioned against each work in the tender notice.

Note: Offers of the Tenderers not meeting the above requirements are liable to be rejected.

Documents required to be submitted

1. Registration Certificate with ESI and PF Authority/Declaration.
2. Income Tax Returns for last Three years
3. Balance Sheet and Profit & Loss Account for the last 03 years by auditor.
4. Availability of Technical personnel in letter head.
5. Registration with BHEL/CPWD/other Govt. organization/PSU if any.
6. Declaration for full filling the BOCW requirements.
7. List of equipment to be mobilized at site.
8. GST Registration details or Declaration.

All the supporting documents to be signed and sealed by the bidder (BHEL have the rights to verify the original documents if required)



INFORMATION TO THE TENDERER:

- (i) Successful Bidder should establish their Site office at Construction site, including common facilities such as toilet, water, electricity etc. in consultation with BHEL. Contractor has to arrange water and power as required for completing the job in the stipulated time frame at their own cost.
- (ii) Contractors shall take at most care on their manpower deployed, considering the current outbreak due to COVID-19, contractor shall take all precautionary measures and follow guideline issued by state and central government to contain and spreading of CORONA VIRUS.
- (iii) Contractor shall issue face mask and gloves to the labours and maintain social distancing while carrying out the work. WEARING OF FACE MASK AND GLOVES IS MANDATORY AT THE WORK PLACE.
- (iv) The bidders should furnish "Site Inspection Certificate" in Annexure-III enclosed herewith.
- (v) Bidders should study the prevailing Market trend of Construction materials/laborers/other relevant requirement before quote and submit the competitive price.
- (vi) The bidder should encourage to use local labor that has the necessary skills as per the requirement of work.
- (vii) Before engaging the labour in to work, Contractor should get the NOC from labours' native police station as well as NOC from local police station (If applicable).
- (viii) The bidders should carry out preliminary survey at proposed construction site before submission of offer to ensure that the rate quoted for the relevant schedule of items are correct.
- (ix) Contractor to note BHEL reserves the right to get any part of the work done through other agency or deploy BHEL's own/hired/otherwise arranged resources, at the risk and cost of the contractor after due notice of a period of two weeks by BHEL, in the event of:-
 - a) Contractors continued poor progress
 - b) Withdrawal from or abandonment of the work before completion of the work.
 - c) Contractor's inability to progress the work for completion as stipulated in the contract
 - d) Poor quality of work
 - e) Corrupt act of Contractor
 - f) Insolvency of the contractor
 - g) Persistent disregard to the instructions of BHEL
 - h) Assignment, transfer, sub-letting of contract without BHEL's written permission
 - i) Non fulfillment of any contractual obligations
 - j) In the opinion of BHEL, the contractor is overloaded and is not in a position to execute job as per required schedule.
- (x) The liquidated damages/penalties arising out of Risk and Cost as explained under Sl.no (vii). BHEL shall recover the amount from any money due from Contractor, or from any money due to the contractor including security deposit, or by forfeiting any T & P or material of the contractor under this contract or any other contract of BHEL or by any other means or any combination thereof.



(ix) **Documents to be submitted on award of work (as applicable):**

- a) Security deposit in the form of Cash/DD/ NSC's / Kisan Vikas Patra / FDR / Bank Guarantee in favour of BHEL
- (b) Electronic Fund Transfer Form duly signed & sealed by banker along with cancelled cheque copy
- (c) Labour license of the workmen engaged valid for contract period (If applicable)
- (d) Workmen Compensation Insurance Policy for the workmen engaged valid for contract period
- (e) Deduction of statutory taxes (as applicable) at source would be enforced from the running bills at the rates prescribed unless exemption certificate is produced from the concerned authorities.

The following documents are to be submitted along with the Running Account Bills for process of payment

- a) Tax Invoice with details of GST number of BHEL and contractor.
- b) Measurement books duly filled and signed by officials of BHEL and contractor
- c) Provident PF Remittance challan for the bill duration.
- d) ESI Remittance challan for the bill duration.
- e) Invoice submitted along with running bills to indicate the GST amount charged and bear GST NUMBER etc. as per prevailing taxes.

Bill submitted subsequently to be accompanied with a declaration that GST liability on the earlier bill has been discharged.

- i) by paying money to the Government (along with Tax paid Challan Copy)
- ii) by utilization of Input GST Credit
- f) BOCW Registration and payment proof.
- g) Field quality assurance documents (as applicable) as per instruction of Engineer In-charge.
- h) List of supplier/supplier's (material and manpower).
- i) After completion of work, bidders should mandatorily furnish NOC from all declared suppliers along with the running/Final Bill.

Mobilization at site:

- 1) Requisite Material (all construction materials like cement, sand, coarse aggregate, reinforcement steel, etc.), men (mason, carpenter, bar binder, fabricator, etc.) and machinery (DTH, Concrete mixer machine/RMC/AJAX with printing facility, Power chain saw, JCB/excavator/dozer, grader, tipper, etc., Total station & other equipment required for building works and levelling, grading works, and other associated works as listed in BOQ) should be arranged in order to complete the project within stipulated time period.
- 2) The contractor shall carry the work as per the approved Field Quality Plan issued by BHEL (Field quality plan enclosed with this tender for reference)
- 3) Calibration of equipment's should be done by NABL accredited laboratories.
- 4) Contractor shall submit the design mix report (from NABL/Govt. approved labs) and shall carry the work as per the approved design mix report, approved by BHEL/GSECL
- 5) Contractor shall conduct the pile load test (Initial and routine test) (OR) any test (as applicable) and shall submit the report (from NABL/Govt. approved labs) as approved by BHEL/GSECL.



Bharat Heavy Electricals Limited
ELECTRONICS DIVISION
MALLESWARAM- BANGALORE-12
INSTRUCTIONS TO TENDERER

1. Sealed Tender for the above noted work is hereby invited from Contractors experienced in similar civil works like mentioned in PQC.
2. Scope of work for, **“Construction of Roads, Drains, Culvert and 4 Nos. 2.5 Lakh Litres Capacity of Underground RCC Water Tank for 100 MWp Solar PV Plant for GSECL, Raghnesda Phase-II”** at location as specified under Sl. No. 3 “Project scope, detail and location” as per Tender/approved construction drawing, works as per instruction of Engineer in charge, terms and condition of contract. However, depending on site conditions minor modification in works may be necessary.
3. Project Scope, detail and Location:

Site Detail	Project detail	Location	Scope of Work
Project Site	100MWp (AC) SPV Power plant for GSECL	RAGHANESDA PHASE-II	100MWp (AC)

4. **Tenders should be addressed to: Smt. BHAGYASHREE S N. GM (SC&PV- ENGG, BHEL- Solar Business Division CPBG- Control Panel shop-78 Professor C.N.Rao Circle, In-front of IISC Malleswaram, Bangalore-560012. In three separate sealed cover for “Technical cum Commercial Bid”, Price Bid and DD for Tender Document Cost (if applicable) & EMD duly super scribed and put in an outer envelope, super scribing the Name of work, Tender no. and Name and address of the Tenderer.**
5. The local address of the Contractors, the name of the person to whom all the Correspondence are to be addressed should be indicated, with telephone number (both office and residence).
6. All entries in tender documents should be in one ink (preferably blue ink). Erasing and overwriting is not permitted. All corrections should be duly signed by tenderer concerned.
7. Tenderers shall fill in all the required particular in the blank space provided for this purpose in the tender documents and also sign in each and every page of the tender document including the drawings attached there to before submitting tender.
8. Unit rate/percentage above or below estimate should be quoted in figures as well as in words in Indian Currency only i.e. Rupees and Paisa with reference to each item and for the items shown in the attached schedule. These rates shall be for the finished work at site. The rate shall include all taxes and duties payable on account of Octroi, Sales Tax, tax on work contract etc., (as applicable) and also expenses towards PF and ESI contributions (see clauses 8, 40 and Enclosure ‘C’) but excluding GST.

NIT Issued By
Thavamani Charles
Dy. Manager, BHEL-SBD

CONTRACTOR (SIGN & SEAL)



9. In case the rate quoted in figures differs from those quoted in words, the lower of the rates quoted will be taken as the tendered rate and shall be binding on the tenderer.
10. The rate to be quoted by the tenderer shall be firm and shall cover and include all statutory levies such as "BOCW, Octroy, excise duty etc., arising from Act passed by Parliament or State Legislature and rules framed there under. The rates shall further be deemed to include statutory levies arising from such Acts, Central or State, which may come into force, subsequent to submission of tenders.
11. (a) The rate quoted in the tender shall remain valid for a period of 'THREE MONTHS' from the date of opening tender.
(b) Tenderer shall not increase quoted rates, once the tenderer has submitted offers/quotation/price and during execution of contract in case tender is accepted.
(c) Successful bidder should execute the work strictly in accordance with Tender schedule quoted rates as accepted by BHEL.
(d) **PRICE VARIATION clause not applicable.**
12. The rates quoted should be inclusive of all taxes arising on the transaction. If BHEL is required to discharge the liability of any taxes on the transaction like TDS(IT), TDS(WCT), TDS(GST) (as applicable) under reverse charge mechanism or any other similar taxes, which is or becomes payable by BHEL, the same shall be deducted from the bills of the contractor. **The rate/Percentage quoted by bidder shall be including all taxes but excluding GST which shall be shown separately in price bid.**
13. Quantities shown in the schedule are only approximate and are liable to variation without entitling the Contractors to any compensation.
14. Before tendering, the tenderer are advised to inspect the site of work and its environments and be well acquainted with the actual working and other prevailing conditions, position of material and labour. They should be well versed with BHEL General Conditions of Contract instruction to the tenderers, drawing and specification and all other documents which form part of the agreement to be entered into subsequent to award of work. The tenderer should be specially note that it is tenderers responsibility to provide any items which is not specifically mentioned in the specifications and drawing, but which is necessary to complete the work.
15. Details and quantities of each item of work shown in the bill of quantities attached here to only approximate. They are given as a guide for the purpose of tendering only and are liable for variation and alteration at the discretion of the competent authority. The work under each item as executed shall be measured and price at the corresponding rates to be quoted by the Contractor in the bill of quantities attached hereto.



16. Should a tenderer find discrepancies or omission in the drawing attached to the tender documents or should be in doubt as to their meaning he should at once address to the authority inviting the tender for clarifications. Every endeavor is made to avoid any error which can materially affect the basis of the tender but successful tenderer shall take upon himself to provide for the risk of any error which may be subsequently discovered and shall make no subsequent claim on account thereof.
17. In the event of the tender being submitted by a firm the tender must be signed separately and legibly by each partner or member of the firm or in their absence, by the person holding the power of Attorney on behalf of firm concerned. In the latter case, a copy of the power of Attorney duly attested by a Gazette Officer must accompany the tender.
18. If in any case, the date of Tender Opening falls on holiday, the Tender will be opened on the next working day.
19. Every tender must be accompanied by Earnest Money Deposit. This earnest money will be refunded to the unsuccessful tenderer after finalization of the award of work. In the case of successful tenderer, the earnest money will be retained as a part of Security Deposit for satisfactory completion of the work in accordance with Clause-16 of BHEL General Conditions of the Contract. Tenders without Earnest Money Deposit receipt are liable to reject. No interest will be paid on the earnest money deposit.
20. **The Earnest money deposit may be furnished**
 - a) **Demand Draft in favour of BHEL SBD, Bangalore – 560012.**
 - b) **The Earnest money deposit may be furnished through online from SBI Collect.**
 - c) **Bank Guarantee as per Sl. No. 4 (b), page No. 1.**

Guidelines for payment of EMD Fee

Step-1: Please enter the following link in your internet address browser or click on the following link.
<https://www.onlinesbi.com/sbicollect/icollecthome.htm>

Please click on "proceed" after Clicking "Check Box" to proceed for payment

Step-2: Now the SBI's SB-Collect site gets opened. Please select State of Corporation as "Karnataka" and type of Corporation as "PSU-PUBLIC SECTOR UNDERTAKING" and then click on "Go" appearing on the screen.

Step-3: Now select "Bharat Heavy Electricals LTD" from the dropdown table appearing against "Industry Name" and click Submit

Step-4: Now select "Others" from the dropdown table appearing against "Category" and click Submit

Step-5: The below screen (similar) will appear. Please select sub category "EMD" and fill up other details and transfer money.



State Bank Collect / State Bank Collect

State Bank Collect



BHARAT HEAVY ELECTRICALS LTD
BHEL HOUSE, SIRI FORT, NEW DELHI-110003

Provide details of payment

Select Payment Category *	OTHERS
SUB CATEGORY *	--Select SUB CATEGORY--
NAME *	<input type="text"/>
VENDOR CODE	<input type="text"/>
AMOUNT *	<input type="text"/>
Remarks	<input type="text"/>

Please enter your Name, Date of Birth (For Personal Banking) / Incorporation (For Corporate Banking) & Mobile Number. This is required to reprint your e-receipt / remittance(PAP) form, if the need arises.

Name *	<input type="text"/>
Date of Birth / Incorporation*	<input type="text"/>
Mobile Number *	<input type="text"/>
Enter the text as shown in the image *	<input type="text"/> 87E21

21. For reimbursement of Earnest Money Deposit, the tenderer should fill the enclosed EFT form, obtain the Banker's signature and also enclose a photocopy of cancelled cheque leaf.
22. EMD may be submitted in Bank guarantee as per Sl. No. 4 (b), page No. 1, in BHEL format in Non-judicial stamp paper amounting Rs.200 (or) applicable rate at bidder's state, whichever is higher. **Bank guarantee from any Co-operative banks are not acceptable in any circumstances.**
23. Unless the bidder whose tender is accepted signs contract agreement (if applicable) within fifteen days (15 days) of the date of the order directing to do so, the amount of Earnest Money already deposited by bidder will be forfeited and acceptance of the tender withdrawn as per discretion of BHEL.
24. If after opening of tenders a tenderer revokes the tender or increase of earlier quoted rates or after acceptance of his tender does not commence the work in accordance with the instruction of Engineer-in-charge, the Earnest Money Deposited by bidder will be forfeited and acceptance of bidder's tender withdrawn.

If only a part of work included in the tender had been awarded to the tenderer, the amount of Earnest Money to be retained will be based on value of the contract so awarded.



25. The BHARAT HEAVY ELECTRICALS LIMITED reserve the right to reject any or all the tenders received or accept any tender or part thereof without assigning reason thereof. In the case of acceptance of a part of tender, the time for completion may also be reduced to the extent considered necessary by the accepting authority.
26. Conditional and Unsigned tenders, tenders which are incomplete or otherwise considered defective, tenders which are not in accordance with the tender conditions laid down by the accepting officer and tenders not submitted in the prescribed forms are liable to be rejected.
27. Tenderer shall submit Solvency Certificate for the value specified from a Bank of standing regarding the tenderer's financial position (as applicable).
28. The tenderers should enclose relevant documents regarding constitution of firm i.e. Individual / Sole Proprietorship Concern / Partnership Firm / Public Limited Company / Private Limited.
29. The tenders should be enclosed with a list of contracts already held by the tenderer at the time of submitting the tender and giving the following particulars:
 - a) Name of the work, value and address.
 - b) The balance work remaining to be done on the same.
30. a) The filled tender sealed cover shall be handed over/couriered/speed post to at office of **"Smt. BHAGYASHREE S N, GM (SC&PV- ENGG, BHEL- Solar Business Division CPBG- Control Panel shop-78 Professor C.N.Rao Circle, In-front of IISC Malleswaram, Bangalore-560012)"** before the time fixed for submission of tender.
 - b) Tenders received after the due date & time of opening of tenders will be rejected.
31. The Contractors responsibility under this contract shall commence from date of receipt of the order or acceptance of tender.
32. Tenders submitted by speed post or courier service shall be posted with due consideration of any delay in postal delivery. Tenders received after the due date of opening tenders are liable to be rejected.
33. If proprietor or partner of a firm expires after the submission of tender or after the acceptance of tender, BHEL reserves the right to cancel the contract if the character of the firm undergoes a substantial change.
34. THE BHARAT HEAVY ELECTRICALS LIMITED will not be bound by any power of Attorney granted by the tenderer or changes in the composition of firm made subsequent to signing of the contract. They may however recognize such power of Attorney and changes after obtaining proper legal advice.



35. If the tenderer deliberately gives wrong information on tender regarding past unsatisfactory performance with BHEL sister units, BHEL reserves the right to reject such tender at any stage including contract execution period.
36. Words imparting the singular number shall also be deemed to include the plural number and vice-versa where the context so require.
37. The General and Special Conditions are complementary to each other and where they are in conflict, the special condition shall prevail.
38. The expenses for completing the stamping agreement shall be paid by the contractor.
39. Unless or otherwise stated above tendered work includes men, material, machine and commissioning of equipment as agreed to in the contract.
40. After completing of the job, the contractor has to furnish actual drawings of work done in consultation with Engineer-in-charge.
41. Any covering letter and comments of the tenderer should be submitted along with the offer.
42. Cement and steel for carrying out Civil Works will have to be procured by the Contractor. Materials shall be accompanied with Test certificates and connected dispatch documents for proof of source from approved manufacturer's works or stockyard. The Contractor shall provide all the materials needed for trial run, testing including chemicals, consumables etc. In quoting their rates, the Contractors are advised to take into account the cost of the above materials. All the construction materials should be approved by BHEL before commencement of work.
43. Contractor are required to follow Field Quality Plan (FQP) for Civil construction as approved by BHEL/customer in respect of Tests to be carried out and reports and documents to be furnished.
44. Should a tenderer or a contractor has a relative or in the case of firm or company, any of its shareholders relative is employed in Bharat Heavy Electricals Limited, the authority inviting tenders shall be informed of this fact at the time of submission of the tender, failing which tender may be disqualified or if such fact subsequently comes to light.
45. These 'INSTRUCTIONS TO TENDERER' & GENERAL CONDITIONS OF CONTRACT OF BHEL' shall be deemed to form an integral part of the Contract agreement for the work to be entered into. The Contractor has to scrutinize the same, and when submitting his tender, indicate his acceptance of both. In cases of variation between the two in any matter, the conditions in the 'THE INSTRUCTIONS TO TENDERER' shall prevail. (Extracts of important clauses of BHEL GCC are enclosed).
46. All operations to be carried out by the Contractor during the execution of the contract such as drilling, welding etc., shall be done with proper equipment to be brought by the tenderer. Contractor shall make his own power and water supply.



47. The Contractor shall comply with the provision of Employees Provident Fund's and miscellaneous Provisions Act 1952 and rules, regulations and other orders issued there under. He as an employer shall be liable to pay employer's contribution/deductions towards PF under the PF Act in respect of all labour employed by him for the execution of the contract in accordance with the provisions of the Employees' Provident Funds and Miscellaneous Provisions Act, 1952 as amended from time to time. For this purpose he shall indicate the code number obtained from the Regional Provident Fund Commissioner or he should obtain a code number if he has not and produce the Photostat copy of the challan receipt of monthly remittance of the contribution made by him to the Commissioner. He shall also furnish such returns such returns as are due, under the Act, to be sent to the appropriate authorities through the Principal Employer".
48. The Contractor should get himself registered with the E.S.I Authorities as an independent Employer, obtain a separate code number and remit the dues in respect of the Labour employed by him for the work and produce the challan/Receipts of remittance of the ESI contributions due under the E.S.I Act to the Company authorities. He shall also furnish such returns, as are due, under the Act, to be sent to the appropriate authorities' through the Principal Employer. The contractor can remit their ESI & PF through a sub-agent who processes the ESI & PF code and agrees to enter an MOU with the contractor.
45. If any action is brought in by P.F. Commissioner/ESI authorities on BHEL for the work done by the Contractor for his labourers regarding PF/ESI amount due, short remittances, non-remittances etc., the Contractor shall defend the case on behalf of BHEL and / or reimburse BHEL the expenses so incurred.
46. The Contractor shall apply and obtain license under Contract labour (R&A) Act 1970 and comply the relevant provisions of this Act in respect of the labour employed by him for executing this contract. The contractor shall furnish necessary returns to the authority through the Principal Employer.
47. Contractor shall insure all his labourers and material. Any claim by his Employees for damages shall be settled by the Contractor even if action is against BHEL or to reimburse the legal expenses incurred by BHEL.
48. Any action brought in by anybody on BHEL regarding patent, right etc., used by Contractor in execution of work shall be defended by the Contractor and / or reimburse BHEL the cost of the same.
49. Contractor shall produce necessary records, documents; explanation whenever he is called upon to do by any Government Agencies.
50. Contractor should obtain "Workmen Compensation Policy" for their Employees.



51. LEAD, LIFT, DEWATERING ETC.,

- a) Unless otherwise specified in the tender schedule, the rates for all items will be deemed to include all leads, lifts and descents involved in the work.
- b) No separate payment will be made for dewatering (including seepage, surface drainage and monsoon water) desludging and allied operations at any stage of the work, and the cost of such operations will be deemed to be included in the contract rates.
- c) No separate payment will be made for curing including pumping of curing water where ever necessary.

52. EXTRA ITEMS

No extra items of work shall be carried out by the contractor other than those authorized to do so in writing by the Engineer-in-charge. For any such items of work executed as per instructions of Engineer-in-charge, the rates will be fixed on the basis indicated under clause 50 of BHEL GCC/as per terms and conditions of BHEL. The schedule of rates to be followed in this case will be CPWD schedule of rates.



BHARAT HEAVY ELECTRICALS LIMITED

(ELECTRONICS DIVISION)

MALLESWARAM - BANGALORE-26

GENERAL CONDITIONS OF CONTRACT/TECHNICAL SPECIFICATION

It is hereby agreed by me/us that the BHEL General Conditions of Contract including subsequent amendments/ additions/deletions to clauses if any, and conditions pertaining the settlement of disputes by Arbitration form an integral part of the tender documents and that the tender submitted by me/ us is subject to the aforesaid BHEL General Conditions of Contract/ Technical Specification for scope of tender works which has been read and accepted by me/us.



SAFETY CODE

RESPONSIBILITIES OF THE CONTRACTOR IN RESPECT OF SAFETY OF MEN, EQUIPMENT, MATERIAL AND ENVIRONMENT

1. Before commencing the work, contractor shall submit a "SAFETY PLAN" to the authorized BHEL Official. The 'SAFETY PLAN' shall indicate in detail the measure that would be taken by the contractor to ensure safety of men, equipment, material and environment during execution of the work. The plan shall take care to satisfy all requirements specified hereunder. The contractor shall submit Safety Plan along with his offer. During negotiations before placing of work order and during execution of the contract BHEL shall have right to review and suggest modification in the Safety Plan. Contractor shall abide by BHEL decision in this respect.
2. The contractor shall take all necessary safety precautions and arrange for appropriate appliances as per direction of BHEL or its authorized officials to prevent loss of human lives, injuries to personnel engaged, and damage to property and environment.
3. The contractor shall provide to its work force and ensure the use of the following personal protective equipment as found necessary and as directed by the authorized BHEL Officer:-Safety Helmets conforming to IS-2925: 1984.
 - (i) Safety Belts conforming to IS-3521: 1983.
 - (ii) Safety Shoes conforming to IS-1989: 1978.
 - (iii) Eye and Face protection devices conforming to IS-8520: 1977 and IS-8940: 1978.
 - (iv) Hand and body protection devices conforming to:
 - IS-2573: 1975
 - IS-6994: 1973
 - IS-8807: 1978
 - IS-8519: 1977

All tools, tackles, lifting appliances, material handling equipment scaffolds, cradles, safety nets, ladders, equipment's etc. used by the contractor shall be of safe design and construction. These shall be tested and certificate of fitness obtained before putting them to use and from time to time as instructed by authorized BHEL Official who shall have the right to ban the use of any item.

All electrical equipment's, connections and wiring for constructions power, its distribution and use shall conform to the requirement of the Indian Electricity Act and Rules. Only electricians licensed by the appropriate statutory authority shall be employed by the contractor to carry out all types of electrical works.



All electrical appliances including portable electric tools used by the contractor shall have safe plugging system to source of power and be appropriately earthed. The contractor shall not use any hand lamp energized by electric power with supply voltage of more than 24 volts. For work in confined space lighting shall be arranged with power sources of not more than 24 volts.

The Contractor shall adopt all fire safety measures as laid down in the "Code for fire Safety at Construction Sites" issued by the Safety Department of the Construction Management (HQ) of BHEL and as per directions of the authorized BHEL Official. A copy of the above referred "Code of Fire Safety at the Construction Sites" shall be made available by BHEL to the contractor for reference, on demand by the contractor, during tendering stage itself.

Where it becomes necessary to provide and/or store petroleum products, explosives, chemicals and liquid or gaseous fuel or any other substance that may cause fire or explosion, the contractor shall be responsible for carrying out such provisions and/or storage in accordance with the rules and regulations laid down in the relevant government acts, such as Petroleum Act, Explosives Act, Petroleum and Carbides of Calcium Manual of the Chief Controller of Explosives, Govt. of India. etc., prior approval to the authorized BHEL Official at the site shall also be taken by the contractor in all such matters.

The contractor shall arrange at his cost (wherever not specified) appropriate illumination at all work spots for safe working when natural daylight may not be adequate for clear visibility.

The contractor shall be held responsible for any violation of statutory regulations local, state or central and BHEL instructions that may endanger safety of men, equipment, material and environment in his scope of work or another contractor or agencies. Cost of damages if any, to life and property arising out of such violation of statutory regulations and BHEL instructions shall be borne by the contractor.

In case of a fatal or disabling injury accident to any person at construction sites due to the lapses by the contractor, the victim and/or his/her dependents shall be compensated by the contractor as per statutory requirements. However, if considered necessary, BHEL shall have the right to impose appropriate financial penalty on the contractor and recover the same from payments due to the contractor for suitably compensating the victim and/or his/her dependents. Before imposing any such penalty, appropriate enquiry shall be held by BHEL giving opportunity to the contractor to present his case.

In case of any damage to property by the contractor, BHEL shall have the right to recover cost of such damages from payments from payments due to the contractor after holding an appropriate enquiry.

In case of any delay in the completion of a job due to mishaps attributable to lapses buy the contractor; BHEL shall have to recover cost of such delay from payments due to the contractor, after notifying suitably and giving him opportunity to present his case.



If the contractor fails to improve the standards of safety in its operation to the satisfaction of BHEL after being given a reasonable opportunity to do so; and/or if the contractor fails to take appropriate safety precautions or to provide necessary safety devices and equipment or to carry out instructions regarding safety issued by the authorized BHEL Official, BHEL shall have the right to take corrective steps at the risk and cost of the contractor after giving a notice of not less than seven days indicating the steps that would be taken by BHEL.

The contractor shall submit report of all accidents, fires and property damage, dangerous occurrence to the authorized BHEL Official immediately after such occurrence, but in any case not later than twelve hours of the occurrence. Such reports shall be furnished in the manner prescribed by BHEL. In addition, the contractor to the authorized BHEL Official shall also submit periodic reports on safety from time to time as prescribed.

Before commencing the work, the contractor shall appoint/nominate a responsible officer to supervise implementation of all safety measures and liaison with his counterpart of BHEL.

If safety record of the contractor in execution of the awarded job is to the satisfaction of Safety Department of BHEL, issue of an appropriate certificate to recognize the safety performance of the contractor may be considered by BHEL after completion the job



SPECIAL CONDITONS OF CONTRACT

1. GENERAL

The special conditions of contract and other contract documents are complimentary to each other and shall be read in conjunction with each other. In case of any conflict of meanings between the special conditions of contract and the BHEL General Conditions of Contract the provisions of the special conditions of contract shall override the corresponding provisions of the BHEL General Conditions of Contract.

2. SCOPE OF WORK

The scope of work includes for the full, final and entire completion of **“Construction Of Roads, Drains, Culvert and 4 Nos. 2.5 Lakh Litres Capacity of Underground RCC Water Tank for 100 MWp Solar PV Plant for GSECL, Raghnesda Phase-II”** as detailed in specifications and drawings, which forms part of this Contract. The scope of work also includes cleaning/removing all debris in line with bill of quantity as directed by Engineer In-charge. The scope of work under this contract shall cover supply of all materials, labour, tools, and plants etc., unless otherwise specified in the specifications, descriptions of items or in foregoing clauses.

3. SITE CONDITIONS

a) Before tendering the Contractor shall get themselves acquainted with site conditions such as the nature of soil likely to be encountered during the course of the work etc,. The rates quoted by the contractor shall be deemed to have been quoted after getting acquainted with the prevailing site conditions. Initial jungle clearance, stripping of top soil etc., shall also be included in the quoted rates. No claims on the pretext of ignorance of site conditions shall be entertained.

b) The site of work is as mentioned in the Tender document.

4. SITE FACILITES

A. LAND

The Employer will allot land as available free of cost to the contractor for his office stores. He must maintain the areas allotted to him in a neat and clean conditions as required by the Employer. The contractor shall provide adequate storage and office facilities with approval from the Engineer. The rate quoted by the contractor shall be deemed to include for these and no separate payment will be made towards these. On completion of work, the site shall be cleaned by the contractor of all materials, temporary debris, rubbish plants and equipment's, belonging to the contractor at no extra cost. The site and surroundings shall be handed over in a neat and clean condition. In case of any failure by the contractor, the employer will get inside cleared at risk and cost of the Contractor.



B. POWER AND WATER SUPPLY

Facilities for drawing Power and water required at site for execution of the works shall be arranged by the contractor at his expense and risk. The necessary source for power & water supply has to be organized by vendor. Necessary distribution box, extension board points duly earthed, and with armoured safe power cables to be laid across the field provided point shall be in the scope of the tenderer. Further, laying of water intake and distribution pipes across the Site to various points of work from Electricity source provided water source point shall be in the scope of the tenderer. If required D.G generation sets shall be provided for Power arrangement by the contractor at his own cost. The tenderer shall make provision for temporary storage of water at suitable locations with pump if required to reach the water supply to work areas. The contractor will have to make his own arrangements for the same, without claiming any extra charge for the power and water drawal and distribution equipment.

5. MACHINERY

The Contractor shall at his own expense, supply all tools, plant and equipment (hereinafter referred to as T & P) required for execution of contract, as specified in the tender documents. whole of the works shall be executed in perfect conformity with the specifications and drawings. If contractor perform any works in a manner contrary to the specifications and drawings and without reference to the Engineer-in-charge, he shall bear all the costs arising or ensuring there from.

- a) All technical documents regarding the construction of works are given in the metric system and work should be carried out according to metric system.
- b) The work shall be carried out as per detailed drawings supplied by the employer. The working drawings shall be emailed progressively to the contractor free of cost. The contractor shall keep one set of drawings (duly protected from dust and wear and tear) at his own expenses always available at site for reference of Engineer-in-charge and other representatives.
- d) The works shall be carried out as per detailed specifications enclosed with the tender. For items for which there is no mention in the drawings, detailed specification relevant IS specification (latest edition) shall be followed.
- e) The contractor shall submit to the Employer for their approval complete drawings, of all temporary works and staging which he may require for carrying out the works shown in the drawings.

He shall at the same time if so required by the Employer submit his calculations relating to strength and anticipated deflection in respect of any aforesaid temporary works. He shall also



submit for the approval of Employer drawings showing the methods he proposes to adopt for the erection of the various parts of the temporary works. Any modification to the drawings that may be required by the Employer shall be made by the contractor at his own cost. However, notwithstanding the approval of modification required for temporary works, the contractor shall be fully responsible for their efficiency, security and maintenance and for all obligations and risks in regard to such works, specified or implied in this contract and be shall reinstate the same at his own cost, should any mishap or accident occur causing damage or injury there from, subject however, to such clauses of the General conditions as may be applicable in such cases.

6. BENCH MARKS AND REFERENCE POINTS

The contractor shall construct and maintain proper benchmarks and reference points of the inter section of all main walls, no separate payment shall be made for this and rates quoted deemed to include this cost. Surveying where ever required is in contractor scope.

7. SAFETY PRECAUTIONS

The contractor shall at times observe the safety code and make necessary action as required in the tender. In default thereof, the employer may get this done departmentally or through other agencies and recover the cost from the contractor.

The Contractors shall also abide by all the security regulations promulgated from time to time by employer.

8. RATES

The rates to be quoted are intended to provide for works duly and properly completed in accordance with the general and special conditions of contract and specifications and drawings together with such alteration and/or conditions as may be required / ordered without prejudice to the generality thereof shall include for detail of construction which are obviously and fairly intended and which may not have been specifically referred in these documents and working drawings and but are essential for execution and satisfactory completion of work including those of minor nature and shall be deemed to include and cover internal the followings.

- a) Arrangements for obtaining the clearance wherever required from statutory bodies, regarding license for construction, permanent electricity, water supply, and sanitary connections including payment of necessary fees, inspection charges and obtaining financial certificates for using these services.

The various items rates quoted in the schedule as applicable shall be deemed to include the above services and no separate payments shall be made towards these.



- b) The cost of all superintendence and labour materials, tools, plants, equipment's, mobilizing and demobilizing equipment fuel lubricants, fixture, transport charges, temporary and permanent works and quarrying charges, testing, screening, washing, handling of materials, stacking and removal charges, of any rejected materials and water and power arrangements and satisfactory maintenance of the same satisfactory completion of the work intended.
- c) All fees, duties, royalties, rent and compensation to owner for surface damage or taxes and impositions payable to local authorities, in respect of land an structure, for all materials supplied for the work or any other duties/expenses for which the contractor may become liable or may be put to under any provision of the law for the purpose of in connection with the execution of the contract including levies payable on the transactions.
- d) Settings out of works profiles etc., and of construction repair and up-keep of all centre lines, bench marks and levels and page there of including provisions of masonry/concrete pillars showing the centre line of structure/gridlines and levels and maintenance and protection of the some including providing fencing etc., throughout the period of contract.
- e) Breaking, maintenance and removal of temporary works and buildings.
- f) Supply of complete, Moulds, cost of testing of materials etc.
- g) Working in all conditions including in/under water liquid, conditions etc., and shall also include bailing or pumping out water from the foundations, basements or any other sources of whatsoever de-sludging and allied operation at any stage of work including all suspension period and delays whatsoever. Cost of curing including pumping and cost of water whatever necessary.
- h) In the interest of completion of work within the stipulated time, certain works are to be carried out during the monsoon period also. No separate payment will be made to the contractor for such works and it will be deemed to be included in the contract rates.
- i) Diversion and draining works, protection works, temporary facilities, bridges, gangway.
- j) Work at all depth in foundation below the ground level and in superstructure up to all height above ground level including all lifts and distances involved at any other place of work and disposed/barrow areas.
- k) Unless otherwise specified in the specification schedule cost of all leads/lifts etc.
- l) Provision of centering, scaffolding, strutting props etc.,



- m) All materials and labour required for fencing in a protection against risk of accidents and for providing necessary/planking strutting with hand rails, gumboots, helmets, safety belts etc., during the progress of work.
- n) Prevention on trespassing by providing barrier arrangements for the safety of the public or employees during the provision of works.
- o) Works in all shapes include and curved all sizes as shown are as required.
- p) Cleaning the site after the completion of work all debris, left out construction materials machine equipment's, temporary offices, stores, works shop etc., including dressing the area neat and clean shape.
- q) Such other incidental charges or contingencies as may have been provided for in the specifications.

9. LABOUR COLONIES

Labour camp will not permitted within the project premises.

10. ESCALATION

The rates to be quoted by the tenderer shall be firm and shall cover and include all statutory levies, arising from, acts passed by parliament or by state legislature, the rates shall further be deemed to include statutory levies arising from such Acts, Central or State, which may come in to force subsequent to submission of tenders. The tenderer shall note that no claim for enhancement of rates, on the ground that existing statutory levies have been increased, or that new statutory levies have come in to effect after tender, or on any other ground, will be entertained on any account.

11. QUANTITY

The probable quantities of the several items of work are furnished in the schedule of quantities. It must be clearly understood that neither the probable quantities nor the value of individual items nor the aggregate value of the entire work shall be binding on the Employer/Engineer does not in any way assure the contractor or Guarantee that the said probable quantities are correct or that the work will correspond to these. The Employer/Engineer reserve the right to omit, vary or add to the item/work described in the schedule, of quantities and no claim for compensation will be entertaining on this account.

12. VARIATION/DEVIATION IN QUANTITIES

The contractor shall not make any alteration in addition to or omission from the work as described in the tender document except in pursuance of the written instructions of the Engineer-in-charge. No such deviation from the work described in the tender documents shall be valid unless the same has been specifically confirmed and accepted by the accepting officer in writing and incorporated in the contract. The rates quoted are firm.



13. MATERIALS

BHEL will not supply any materials unless otherwise specified.

14. SUPPLY OF CEMENT, STEEL , PAINT AND OTHER CONSTRUCTION MATERIALS, IS TO BE MADE BY CONTRACTOR

Makes / Source of supply of cement, steel, paint and other construction materials shall be as per approval of BHEL/GSECL

15. SUPPLY BY CONTRACTOR

The work is for a completed job including labour and supply of all materials except those otherwise specified in the bid document.

The material and works shall be subject to inspection and test as per field quality plan (FQP) duly approved by BHEL/GSECL.

All materials supplied by the contractor according to the contract conditions shall be subject to inspection and passing by the Engineer-in-charge or his representatives from time to time, the contractor providing all facilities for such instruction free of cost.

BHEL officers connected with the contract shall have the power at any time to inspect and examine any stores or materials intended to be used in or on the work, whether on the site or at any factory or workshop or other place where such stores or materials are being fabricated or manufactured or at any place the same are lying and the contractor shall give necessary facilities for such inspection and examination.

The Engineer-in-charge shall be entitled to have tests made of any stores or materials supplied by the contractor shall provide at his own expense all facilities which the Engineer-in-charge may require for this purpose. If at the discretion of the Engineer-in-charge an independent expert is employed to make any such tests his charges shall be borne by the contractor only if the tests disclosed that the said stores or materials are not in accordance with the provision of the contract.

Should the Engineer-in-charge/Civil Engineer consider at any time during the construction or reconstruction on prior to the expiry of the Maintenance Period that the stores or materials provided by the contractor are unsound or of quality inferior to that contracted for, or otherwise not in accordance with the contract (in respect where the decision of the Engineer-in-charge/Civil Engineer shall be final and conclusive) the contractor shall on demand, in writing from the Engineer-in-charge specifying the stores or materials complained of, not withstanding that the same may have been inadvertently passed, certified that and paid forth with remove the stores or materials so specified and provide other and suitable stores or materials at his own expense, to the entire satisfaction of the Engineer-in-charge/Civil Engineer and in the event of his failing to do so within a period to be specified by the Engineer-in-charge/Civil Engineer, in his demand aforesaid, the Engineer-in-charge/Civil Engineer may replace within the other stores or materials complained of at the risk and expense in all respect of the contractor.

The liability of the contractor under this conditions, shall not extend beyond the maintenance period aforesaid except as regards stores or materials which the Engineer-in-charge/Civil Engineer shall have previously given notice to the contractor to replace (Maintenance period for any work under this organization will be six months from the date of actual completion of the particular work and handing over to BHEL).



16. INTERRUPTION TO THE WORKS

While quoting the rates/prices the Contractor should take in to account the fact that due to the design or other stipulations at site, or the necessity to follow a particular sequence of overall construction operation, or non-supply of particular drawings, or the connected work or other reasons, interruptions are likely to be encountered in a work of this nature and magnitude. No claims for such interruptions will be entertained on any account.

17. EXTENSION OF TIME OR PENALTY/LIQUIDATED DAMAGES

Extension of time or penalty/liquidated damages as the case may be will be determined as stipulated in clause No. 2.7.9 of BHEL General Conditions of Contract 2019.

18. COMPLETION OF WORK AND MEASUREMENT

- a) All work shall be carried out according to authorized dimensions and measurement will be restricted to those authorized dimension even though the Contractor may for convenience of this work exceed the authorized dimensions.
- b) All work shall be measured in accordance with the applicable standard method of measurements prescribed by the Indian Standard Institution (1200 latest edition) unless otherwise specified.
- c) The Contractor shall admit for technical inspection, works which are likely to be embedded or covered by other works and have the necessary measurement books and certificates to this effect duly signed by the Engineer before the works are covered.
- d) On completion of the work, the Contractor must submit to the Engineer the following documents for passing of works.
 - i) A copy of the working drawing showing there on all addition and alterations in the process of execution.
 - ii) A certificate for embedded and covered up works as in sub-para (C) above
- e) The authorized Contractors representative and a representative of the Employer shall jointly sign a certificate of handing over any completed work and date of signature of that certificate will be that the date from which the maintenance period of that unit will reckoned.
- f) Notwithstanding the above, insurance cover has to be taken by the contractor for the full value of work as also for the duration of the contract period. 50% of the Security Deposit shall be released only on the total completion of the building and handing over to BHEL to their satisfaction. Remaining 50% of Security Deposit shall be released subject to the stipulation in BHEL's GCC after 6 months from the date of completion of the building.



19. MAINTENANCE OF WORK

The contractor will be responsible for the maintenance of works during the period of construction until the various items are taken over, and for a further period of six months, from the date of taking over.

If the contractor fails to maintain the building satisfactorily, it will be got done by other agency and cost towards such maintenance together with departmental charges will be recovered from his bills/dues.

20. SECURITY DEPOSIT

Upon acceptance of the tender, the successful tenderer shall remit the security deposit with Bharat Heavy Electricals Ltd within the time as specified in the Letter of Intent.

The rate of Security Deposit will be 5% of work order value.

The contractor should submit the Security Deposit before the start of the work by

- i) Cash (as permissible under the income Tax Act).
- ii) Pay order, demand draft in favour of BHEL.
- iii) Local cheques of scheduled banks, subject to realization.
- iv) Securities available from Post Offices such as National Saving Certificates, Kisan Vikas Patras etc.,(Certificate should be held in the name of contractor furnishing the security and duly pledged in favour of BHEL and discharged on the back).
- v) Bank Guarantee from scheduled Banks/Public financial Institutions as defined in the companies Act subject to a maximum of 50% of the total security deposit value. The balance 50% has to be remitted either by cash or in the other form of security. The Bank Guarantee format should have the approval of BHEL.
- vi) Fixed Deposit Receipt issued by scheduled Banks/Public Financial Institutions as defined in the Companies Act. The FDR should be in the name of the contractor, A/C BHEL, duly discharged on the back.
- vii) Security Deposit can also be recovered at the rate of 10% from the running bills. However in such cases at least 50% of the Security Deposit should be collected before start of the work and balance 50% may be recovered from the running bills.
- viii) EMD of the successful tenderer shall be converted and adjusted against the Security Deposit. The Security Deposit shall not carry any interest.

NOTE: Accepting of Security Deposit against Sl. No. (iv) and (vi) above will be subject to hypothecation or endorsement on the documents in favour on BHEL. However, BHEL will not be liable or responsible in any manner for the collection of interest or renewal of the documents or in any other matter connected therewith.

For extra items of work and deviated quantities, security deposit will be recovered at 10% of the value of deviated amount. The security deposit will be released as stipulated under relevant clause of GCC 2019.



21. RUNNING ACCOUNT PAYMENTS

During execution of work, monthly payments of all works in place will be made on the basic measurements recorded in measurement sheet/book in respect of items executed but no claim on the account will be entertained, if for any reason payments are not so made. PRICE VARIATION clause not applicable.

22.1 MOBILIZATION ADVANCE/ADVANCE PAYMENT - NOT APPLICABLE

22.2 INTEREST & RECOVERY - NOT APPLICABLE

23. Statutory Deduction towards Income Tax will be made as per rules.

24. In respect of all labour directly or indirectly employed on the work by the Contractor, the Contractor shall comply with the provisions of the contract labour (Regulation and Abolition) Act 1970 or any amendment thereof and all legislations and rules of the State and or Central Government or other Authority (**Whichever is higher**), framed from time to time governing the protection of health, sanitary arrangements, wages, welfare and safety for labour employed on building and construction works. The rules and other statutory obligations with regard to fair wages, welfare and safety measures, maintenance of the register etc., will be deemed to be part of the contract.

25. The Contractor is required to take insurance for all workers employed on works towards payment for workmen compensation. The insurance has to be taken out within 15 days of the award of work and has to be produced at the time of signing agreement. Half (1/2%) shall be deducted for every bill if the contractor fails to produce a proof of having taken such an insurance to cover his workmen. However the contractor shall be fully responsible for all the consequences arising out of such default. This may also be read with relevant clauses of BHEL GCC 2019.

25. TIME OF COMPLETION

The date of commencement of work shall be counted from the date of handing over the site to the contractor. It may be clearly understood that time is the essence of the contract and the entire work should be completed within the time imposed in the tender document letter of intent.

26. The Contractor has to pay the Works Contract Tax (Under relevant section of the State Government Act) of their own on Monthly basis.

27. The management of BHEL shall be at liberty to terminate the contract by issuing a month's notice to the contractor without assigning any reason what so ever. As regards unsatisfactory performance or noncompliance with any of the terms & conditions of the contract by the contractor. The management of BHEL shall have the right to terminate the contractor forthwith without notice & rearrange the balance work through other agencies at the risk & cost of the contractor & under such circumstances, the Earnest Money Deposit/Security Deposit paid by the contractor shall stand forfeited.



28. SPECIAL CONDITIONS OF TENDER

- i) The successful bidder should open local office for Technical staff/Administrative group at Bangalore City for easy interactions/ monitoring of work at site./ Attend meetings at Bangalore city/site as and when instructed by BHEL.
- ii) Tenderers should not disclose any price bid details/discounts in the technical bids.
- iii) The successful bidder should construct site office / toilets for their workmen at site in consultation with Engineer-in-charge.

29. WORKMEN COMPENSATION POLICY

The contractor is required to take Insurance for all the workers employed on the works towards payments for workmen compensation. The Insurance has to be taken out within 15 days of the award of work and has to be provided at the time of signing the agreement. Half percent (0.5%) of the amount shall be deducted from every bill if the contractor fails to produce a proof of having taken such an insurance to cover his workmen. However the contractor shall be fully responsible for the consequences arising out of such default.



LIST OF INDIAN STANDARD

Following is the list of various Indian Standards,
Relevant to the Civil Engg., work

1. EARTH WORK

- i) IS 1200-1992, Method Part I Earthwork, Measurement of Building, and Civil Engineering works, and chapter No.2 of CPWD/specification 1977.

2. MORTAR (PLASTERING)

- 1) IS 2394-1984: Code of practice for application of lime plasters finish.
- 2) IS 1661-1972: Code of practice for application of cement lime plasters finish.
- 3) IS 2402-1963: Code of practice for external rendered finishes.

3. CONCRETE WORK & RCC WORK

- 1) IS 456-2000: Code of practice for plain and reinforced concrete.
- 2) IS 432(part 1) –1982(Third Revision): Mild steel and medium tensile steel bars
- 3) IS 1766-1998: Cold twisted steel bars for concrete reinforcement.

4. BRICK WORK

- 1) IS 2212-1991: Code of practice for brick work.

5. STONE WORK

- 1) IS 1597-1992 (Part – I & II): Code of practice for construction of stone masonry.

6. MARBLE WORK

- 1) IS 1124-1974: Methods of test for water absorption of natural building works.

7. STEEL WORK

- 1) IS 800-2007(Third Revision): Code of practice for use of structural steel in general building construction.
- 2) IS 1308-1984: Steels doors, windows and ventilators
- 3) IS 1081-1960: Code of practice for fixing glazing of metal (steel & aluminium doors, windows & ventilators)
- 4) IS 1161-1998: Steel tubes for structural purposes.
- 5) IS 4351-2003: Steel doorframes.
- 6) IS-6245-5245-1971: Metal rolling shutters and rolling grills.



8. FLOORING

- 1) IS 2114-1984: Code of practice for laying in situ terrazzo floor finish.
- 2) IS 2571-1970: Code of practice for in situ cement concrete flooring.
- 3) IS 5318-1969: Code of practice of lying of flexible P.V.C. sheet & tiles flooring.

9. ROOFING

- 1) IS 3007(pt-I)-1999: Code of practice of lying of corrugated cement sheets.

10. FINISHING

- 1) IS 133-2004: Enamel, Interior (a) under coating (b) Finishing colour as required.
- 2) IS 348-1968: French Polish.
- 3) IS 427-2005: Distemper, dry colour as required.
- 4) IS 425-1969: Distemper, oil emulsion as required.
- 5) IS 5410-1992: Cement paint, Colour as required.
- 6) IS 5411 (pt.1)-1974: Plastic emulsion paint for interior use.
- 7) IS 6278-1971: Code of practice for white washing & color washing.

11. DEMOLISION AND DISMANTILING

- 1) IS 1200 (pt. 18)-1974: Method of measurements of demolition and dismantling.

12. SAFETY CODE

- 1) IS 5916-1970: Safety code for construction including use of hot bituminous materials.
- 2) IS 4130-1991: Safety code for demolition of building.
- 3) IS 3754-1966: Safety code for excavation works.
- 4) IS 3696(Pt-1)-1987: Safety code for Scaffolds.

A) DISTEMPERING ON NEW SURFACE. (OILBOUND)

1. COAT OF PRIMER	0.07 Litre/Sq.m (one coat)
2. COAT OF DISTEMPER	0.10 Kg/Sq.m (2 coats)

DISTEMPERING WITHOUT PRIMER

FOR 1 COAT	0.10 Kg/Sq.m (For 1 coat)
FOR 2 COATS	0.15 Kg/Sq.m (For 2 coats)

B) SYNTHETIC ENAMEL PAINT.

a) ON NEW SURFACE	... PRIMER	0.09 Litre/Sq.m (For1 coat)
ENAMEL PAINT	(2 COATS)	0.15 Litre/Sq.m (For 2 coats)
b) ON OLD SURFACE			
2 COATS WITHOUT PRIMER	...		0.20 Litre/Sq.m
1 COAT	...		0.10 Litre/Sq.m



c) WATER PROOF CEMENT PAINT		
1 COAT	...	0.18 Kg/Sq.m
2 COAT	...	0.30 Kg/Sq.m
d) PLASTING EMULSION PAINT:		
2 COATS OF PLASTIC EMULSION	0.09 Litre/Sq.m
1 COAT OF PLASTIC EMULSION	0.073 Litre/Sq.m
<u>ON NEW SURFACE</u>		
1 COAT PLASTIC FIX PRIMER	...	0.081 Litre/Sq.m
2 COATS PLASTIC EMULSION	...	0.09 Litre/Sq.m

These standards are indicative, any additional IS standard/specification required to be followed shall be adhered to by the contractor/bidder.



FORM OF TENDER

Having examined the invitation to bid, Instructions to Bidder, General conditions of contract, Special conditions, Specifications tender schedule, Contract drawings and other documents for the above work, we the undersigned, offer to construct, erect complete and maintain the whole of the said in conformity with the said bid documents on the terms and conditions and under the provisions set out or called for in the contract documents at the rates listed in the schedule of unit prices or elsewhere in the contract documents.

We undertake if our bid is accepted, to commence the works within 7 days from the date of issue of award and to complete and delivery the whole of the works comprised in the contract as per the time schedule agreed to the contract document.

We agree to abide by this bid for the period of three months from the date fixed for receiving the same and it shall remain binding upon us and may be accepted at any time before expiry of the period.

Until and unless a formal agreement is prepared and executed this bid, together with your award thereof shall constitute a binding contract between us.

Certificate by Chartered Accountant on letter head

This is to Certify that M/S
(hereinafter referred to as 'company') having its registered office at
..... is registered under MSMED Act 2006, (Entrepreneur
Memorandum No (Part-II) dtd:.....
Category: (Micro/Small). (Copy enclosed).

Further verified from the Books of Accounts that the investment of the company as per the
latest audited financial year as per MSMED Act 2006 is as follows:

1. **For Manufacturing Enterprises:** Investment in plant and machinery (i.e. original cost
excluding land and building and the items specified by the Ministry of Small Scale Industries vide its
notification No.S.O.1722(E) dated October 5, 2006 :
Rs.....Lacs
2. **For Service Enterprises:** Investment in equipment (original cost excluding land and building and
furniture, fittings and other items not directly related to the service rendered or as may be notified under the MSMED
Act, 2006:
Rs.....Lacs

(Strike off whichever is not applicable)

The above investment of Rs.....Lacs is within permissible limit of
Rs.....Lacs forMicro / Small (Strike off which is not applicable)
Category under MSMED Act 2006.

Or

The company has been graduated from its original category (Micro/ Small) (Strike off which is not
applicable) and the date of graduation of such enterprise from its original category is
(dd/mm/yyyy) which is within the period of 3 years from the date of graduation of such
enterprise from its original category as notified vide S.O. No. 3322(E) dated 01.11.2013 published
in the gazette notification dated 04.11.2013 by Ministry of MSME.

Date:

(Signature)

Name -

Membership number -

Seal of Chartered Accountant



ANNEXURE II

**Electronic Funds Transfer (EFT) OR
Paylink Direct Credit Form**

Please Fill up the form in **CAPITAL LETTERS** only.
TYPE OF REQUEST(Tick one): _____ CREATE _____ CHANGE

BHEL Vendor / Supplier Code:	
Company Name :	
Permanent Account Number(PAN):	
Address	

City: _____ PINCODE _____ STATE _____

Contact Person(s)	
Telephone No:	
Fax No:	
e-mail id:	

1 Bank Name:	
2 Bank Address:	
3 Bank Telephone No:	
4 Bank Account No:	
5 Account Type: Savings/Cash Credit	
6 9 Digit Code Number of Bank and branch appearing on MICR cheque issued by Bank	
7 Bank swift Code(applicable for EFT only)	
8 Bank IFSC code(applicable for RTGS)	
9 Bank IFSC code(applicable for NEFT)	

- A I hereby certify that the particulars given above are true, correct and complete and that I, as a representative for the above named Company, hereby authorise BHEL, EDN, Bangalore to electronically deposit payments to the designated bank account.
- B If the transaction is delayed or not effected at all for reasons of incomplete or incorrect information, I would not hold BHEL / transferring Bank responsible.
- C This authority remains in full force until BHEL, EDN, Bangalore receives written notification requesting a change or cancellation.
- D I have read the contents of the covering letter and agree to discharge the responsibility expected of me as a participant under ECS / EFT.

Date:

Authorised Signatory:
Designation:

Telephone NO. with STD Code

Company Seal

Bank Certificate

We certify that _____ has an Account No _____ with us and we confirm that the bank details given above are correct as per our records.

Date: _____ (.....)
Place: _____ Signature _____

Please return completed form along with a blank cancelled cheque or photocopy thereof to:

Bharath Heavy Electricals Ltd,

Attn:

Electronics Division, Mysore Road,
BANGALORE - 560 026

In case of any Query, please call : 080-26998xxx / 2674xxxx or fax no. 080-2674xxxx



ANNEXURE-III

(TO BE SUBMITTED IN BIDDER'S LETTER HEAD)

Ref.

Date:

SITE INSPECTION CERTIFICATE (If possible subject to COVID Restriction)

This is to Certify that, I / We.....

..... had inspected the proposed.....
Construction site thoroughly and understood the conditions like soil, climate, etc before quoting the price/offer and also the scope of works to be carried out in line with construction drawings/ designs/ data/ Bill of quantities/ schedule of items / Specifications as brought out in the Tender as desired by BHEL.

Agreeable to all Terms & Conditions of Contract and assure to complete the work

Within the stipulation time frame.

Note: In case of bidder unable to visit the site due to any reason, bidder may kindly note that it is the responsibility of the bidder to ensure and understand the scope of work and site condition in line with NIT terms and condition.

Signature of the contractor

Name:

Seal



(TO BE SUBMITTED IN BIDDER'S LETTER HEAD)

TECHNO-COMMERCIAL DEVIATION SHEET

Tender Enquiry No & Date: **EDN: PVSS:GSECL:100MW:PH-II:RD&DRAIN-WT/CIVIL/02** Dt.: **07.08.2021**

Work Description: Construction of Roads, Drains, Culvert and 4 Nos. 2.5 Lakh Litres Capacity of Underground RCC Water Tank for 100 MWp Solar PV Plant for GSECL, Raghnesda Phase-II

We have gone through the complete tender enquiry and its corrigendum mentioned above and read and understood the Pre- Qualification Criteria, Instructions to Tenderer along with Enclosures, Special Condition of Contract along with its annexures, scope of Work Cum Technical Specification, BHEL General Conditions of Contract 2019 etc.

We hereby confirm that, we have following deviations with technical and commercial terms and conditions of NIT:

Clause No. & NIT page no.	NIT Clause	Deviation proposed	Remarks

Mention any deviations from Tender enquiry if any, else mention “No deviation “

We hereby confirm that except for above, there are no other Deviation from all terms and conditions mentioned in Tender documents.

Seal & Signature of Authorized Representative /Bidder

Name:
Designation:
Date:
Name of Bidder:



(TO BE SUBMITTED IN BIDDER'S LETTER HEAD)

DECLARATION REGARDING MSE (OR) QUALIFYING PPP-MII, ORDER 2017

(WITH SUPPORTING DOCUMENTS)

Tender Enquiry No & Date: **EDN: PVSS:GSECL:100MW:PH-II:RD&DRAIN-WT/CIVIL/02 Dt.: 07.08.2021**

Work Description: Construction Of Roads, Drains, Culvert and 4 Nos. 2.5 Lakh Litres Capacity of Underground RCC Water Tank for 100 MWp Solar PV Plant for GSECL, Raghanesda Phase-II

I/We hereby declare that, I/We..... belong to MSE (or) qualifying PPP-MII, order2017 (relevant supporting documents attached).

We also hereby declare that the information provided is correct to the best of my knowledge.

Seal & Signature of Authorized
Representative /Bidder

Name:
Designation:
Date:
Name of Bidder:



(TO BE SUBMITTED IN BIDDER'S LETTER HEAD)

DECLARATION

Tender Enquiry No & Date: **EDN: PVSS:GSECL:100MW:PH-II:RD&DRAIN-WT/CIVIL/02 Dt.: 07.08.2021**

Work Description: Construction Of Roads, Drains, Culvert and 4 Nos. 2.5 Lakh Litres Capacity of Underground RCC Water Tank for 100 MWp Solar PV Plant for GSECL, Raghanesda Phase-II

(A) Preventive checks to eliminate cartel formation between suppliers

The Bidder declares that they will not enter into any illegal or undisclosed agreement or understanding, whether formal or informal with other Bidder(s). This applies in particular to prices, specifications, certifications, subsidiary contracts, submission or non-submission of bids or any other actions to restrict competitiveness or to introduce cartelization in the bidding process. In case, the Bidder is found having indulged in above activities, suitable action shall be taken by BHEL as per extant policies/ guidelines.

(B) Timely submission of Performance Security

Bidder agrees to submit performance security required for execution of the contract within the time period mentioned. In case of delay in submission of performance security, enhanced performance security which would include interest (SB/ rate + 6%) for the delayed period, shall be submitted by the bidder. Further, if performance security is not submitted till such time the first bill becomes due, the amount of performance security due shall be recovered as per terms defined in NIT I contract, from the bills along with due interest

We also hereby declare that the information provided is correct to the best of my knowledge.

Seal & Signature of Authorized
Representative /Bidder

Name:
Designation:
Date:
Name of Bidder:



Additional Clauses for GST:

1. BHEL GST Number of Nodal Agency:

Nodal Unit Registered as Supplier of Goods/Services in GST: **GUJARAT**

GSTIN of Nodal Unit: Will be intimated later after award of work.

2. HSN (Harmonized System of Nomenclature) / SAC (Services Accounting Code) to be mandatorily mentioned in all quotations & invoices submitted.
3. Invoice submitted should be in the format as specified under GST Laws viz. all details as mentioned in Invoice Rules like GSTN registration number, invoice number, quantity, rate, value, taxes with nomenclature – CGST, SGST, IGST mentioned separately, HSN Code / SAC Code etc.
4. Payment of GST to vendors as applicable will be made only if it is matching with data uploaded by Vendors
5. Vendors to give undertaking that GST as mentioned in the Invoice has been paid/will be paid either through cash or admissible input credit and also file the returns
6. For invoices paid on Reverse charge basis – that it is “payable on reverse charge basis” to be mentioned on the invoice.
7. With respect to supplies, vendor should intimate BHEL immediately on dispatch for parallel billing on customer
8. Vendor should get GST registration, if not available, in the state of Gujarat immediately after placement of order.

UNPRICED PRICE BID (GSECL 100MW RAGHANESDA PH-II)

CONSTRUCTION OF ROADS, DRAINS, CULVERT AND 4 Nos OF 2.5 LAKH LITRES CAPACITY UNDERGROUND RCC WATER TANK FOR 100 MWp SOLAR PV PLANT FOR GSECL, RAGHANESDA PHASE-II

Sl.no	DESCRIPTION	UNIT	QTY	ITEM RATE (Excluding GST)	Amount in Rs.
I	ROADS, DRAINS & CULVERT				
1	Earth work in excavation by mechanical means (Hydraulic excavator) / manual means over areas (exceeding 30cm in depth, 1.5m in width as well as 10 sqm on plan) including rolling, compaction MDD 95% , disposal of excavated earth, lead upto 5 km, lift upto 1.5m, disposed earth to be levelled and neatly dressed. All kinds of soil	cum	375.00	149.12	55920.00
2	Earth work in excavation by mechanical means (Hydraulic excavator) / manual means over areas (exceeding 30 cm in depth, 1.5m in width as well as 10 sqm on plan) including disposal of excavated earth, lead upto 5km, lift upto 1.5 m, disposed earth to be levelled and neatly dressed. Ordinary rock	cum	5.00	289.01	1445.00
3	Earth work in excavation by mechanical means (Hydraulic excavator) / manual means over areas (exceeding 30 cm in depth, 1.5m in width as well as 10 sqm on plan) including disposal of excavated earth, lead upto 5km and lift upto 1.5 m, disposed earth to be levelled and neatly dressed. Hard rock (blasting prohibited)	cum	5.00	833.28	4166.00
4	Filling (borrowed approved soil/Excavated soil) in layers not exceeding 20 cm in depth, breaking clods, watering, rolling each layer with power roller of minimum 8 tonnes to achieve 97% or more of standard proctor's MDD and dressing up, in embankments for roads, flood banks, marginal banks, and guide banks etc., Ensuring required CBR value / as instructed by Engineer in charge				
(a)	lead upto 5 km and lift upto 1.5 m (All kinds of soil)	cum	7122.00	551.35	3926715.00
(b)	lead upto 10 km and lift upto 1.5 m (All kinds of soil)	cum	7122.00	613.67	4370558.00
(c)	lead upto 20 km and lift upto 1.5 m (All kinds of soil)	cum	7122.00	717.24	5108183.00
(d)	lead upto 50 km and lift upto 1.5 m (All kinds of soil)	cum	7122.00	974.06	6937255.00
5	Construction of granular subbase by providing close graded material conforming to spec, mixing at OMG, carriage, lead & lift, spreading of uniform thickness motor graded on prepared surface, compacted with vibratory power roller to achieve 97% or more of standard proctor's MDD as per spec & instruction of engineer in charge.	Cum	5707.00	2064.51	11782159.00
6	Supplying and stacking at site. 63 mm to 45 mm size stone aggregate (WBM Gr-II)	cum	3344.00	1259.23	4210865.00
7	Supplying and stacking at site. 53 mm to 22.4 mm size stone aggregate. (WBM Gr-III)	cum	3344.00	1434.80	4797971.00
8	Supplying and stacking at site. Stone screening 11.2 mm nominal size (Type B)	cum	1445.00	1622.37	2344325.00
9	Supplying and stacking at site Binding material.	cum	642.00	662.40	425261.00
10	Laying, spreading and compacting stone aggregate of specified sizes to WBM specifications in uniform thickness, hand picking, rolling with 3 wheeled road / vibratory roller 8-10 tonne capacity in stages to proper grade and camber, applying and brooming requisite type of screening / binding material to fill up interstices of coarse aggregate, watering and compacting to the required density .	cum	5350.00	629.15	3365953.00
11	Providing and applying tack coat using hot straight run bitumen of grade VG - 10, including heating the bitumen, spraying the bitumen with mechanically operated spray unit fitted on bitumen boiler, cleaning and preparing the existing road surface as per specifications : On W.B.M. @ 0.75 Kg / sqm	sqm	35663.00	34.48	1229660.00
12	2 cm premix carpet surfacing with 1.8 cum and 0.90 cum of stone chippings of 13.2 mm size and 11.2 mm size respectively per 100 sqm. and 52 kg. and 56 kg. of hot bitumen per cum of stone chippings of 13.2 mm and 11.2 mm size respectively including a tack coat with hot straight run bitumen including consolidation with road roller of 6 to 9 tonne capacity etc. complete: (tack coat to be paid for separately). With Refinery Modified Bitumen CRMB 55 conforming to IRC: SP: 53-1999. (Laying of Pre-mix carpet shall be done by Paver only.)	sqm	35663.00	151.37	5398308.00

UNPRICED PRICE BID (GSECL 100MW RAGHANESDA PH-II)

CONSTRUCTION OF ROADS, DRAINS, CULVERT AND 4 Nos OF 2.5 LAKH LITRES CAPACITY UNDERGROUND RCC WATER TANK FOR 100 MWp SOLAR PV PLANT FOR GSECL, RAGHANESDA PHASE-II

Sl.no	DESCRIPTION	UNIT	QTY	ITEM RATE (Excluding GST)	Amount in Rs.
13	Providing and applying tack coat using hot straight run bitumen of grade VG - 10 including heating the bitumen, spraying the bitumen with mechanically operated spray unit fitted on bitumen boiler, cleaning and preparing the existing road surface as per specifications : On bituminous surface @ 0.50 Kg / sqm.	sqm	35663.00	27.59	983942.00
14	Providing and laying seal coat (TYPE A) of premixed fine aggregate (passing 2.36 mm and retained on 180 micron sieve) with bitumen using 128 kg of bitumen of grade VG - 10 bitumen per cum of fine aggregate and 0.60 cum of fine aggregate per 100 sqm of road surface including rolling and finishing with road roller all complete.	sqm	35663.00	60.43	2155115.00
15	Conducting laboratory test on soil samples at an NABL accredited laboratory including preparation of soil samples to determine the CBR test and consolidation in report as per specification	Each	18.00	4250.00	76500.00
16	Earth work in excavation by mechanical means (Hydraulic excavator) / manual means in foundation trenches or drains (exceeding 1.5 m in width or 10 sqm on plan), including dressing, ramming, stabilisation of sides and bottoms, lift upto 1.5 m, including getting out the excavated soil and disposal of surplus excavated soil as directed,within a lead of 5km,disposed earth to be levelled and neatly dressed. All kinds of soil	cum	7962.68	206.89	1647398.00
17	Excavation work by mechanical means (Hydraulic excavator)/ manual means in foundation trenches or drains (exceeding 1.5 m in width or 10 sqm on plan), including dressing, ramming, stabilisation of sides and bottoms, lift upto 1.5 m, including getting out the excavated soil and disposal of surplus excavated soil as directed,within a lead of 5km,disposed earth to be levelled and neatly dressed. Ordinary rock	cum	5.00	367.48	1837.00
18	Filling (borrowed approved soil) (excluding rock) in trenches, plinth, sides of foundations etc. in layers not exceeding 20cm in depth, consolidating each deposited layer by ramming and watering, lead up to 1.5km and lift upto 1.5 m.	cum	52.00	180.11	9366.00
19	Providing and laying in position cement concrete of specified grade excluding the cost of centering and shuttering - All work up to plinth level 1:2:4 (1 cement : 2 coarse sand : 4 graded stone aggregate 20 mm nominal size) with smooth finish.	cum	1525.00	5566.65	8489141.00
20	Providing and laying in position cement concrete of specified grade excluding the cost of centering and shuttering - All work up to plinth level 1:4:8 (1 cement : 4 coarse sand : 8 graded stone aggregate 40 mm/20mm nominal size) with smooth finish	cum	541.00	4747.47	2568381.00
21	Providing and laying in position machine batched and machine mixed designmix M-25 grade cement concrete for reinforced cement concrete work, using cement content as per approved design mix, including pumping of concrete to site of laying but excluding the cost of centering, shuttering, finishing and reinforcement, including admixtures in recommended proportions as per IS: 9103 to accelerate, retard setting of concrete, improve workability without impairing strength and durability as per direction of Engineer-in-charge. All works upto plinth level.	cum	10.00	6557.79	65578.00
22	Steel reinforcement for R.C.C. work including straightening, cutting,bending, placing in position and binding all complete upto all level. Thermo-Mechanically Treated bars of grade Fe-415 CRS .	kg	50.00	68.47	3424.00
23	Centering and shuttering including strutting, propping etc. and removal of form for :Foundations, footings , bases of columns, cover slabs etc. for mass concrete	sqm	149.00	233.58	34803.00

UNPRICED PRICE BID (GSECL 100MW RAGHANESDA PH-II)

CONSTRUCTION OF ROADS, DRAINS, CULVERT AND 4 Nos OF 2.5 LAKH LITRES CAPACITY UNDERGROUND RCC WATER TANK FOR 100 MWp SOLAR PV PLANT FOR GSECL, RAGHANESDA PHASE-II

Sl.no	DESCRIPTION	UNIT	QTY	ITEM RATE (Excluding GST)	Amount in Rs.
24	Steel work welded in built up sections/ framed work including cutting, hoisting, fixing in position and applying a priming coat of approved steel primer and Paint using structural steel etc. as required in gratings, frames, guard bar, ladder, railings, brackets, gates and similar works.	kg	50.00	107.42	5371.00
25	Providing and laying Non Pressure NP-3 class (Medium duty) R.C.C. pipes including collars/spigot jointed with stiff mixture of cement mortar in the proportion of 1:2 (1 cement : 2 fine sand) including testing of joints etc. complete : 450 mm dia. R.C.C. pipe	meter	200.00	1905.60	381120.00
26	Providing and laying Non Pressure NP-3 class (Medium duty) R.C.C. pipes including collars/spigot jointed with stiff mixture of cement mortar in the proportion of 1:2 (1 cement : 2 fine sand) including testing of joints etc. complete :600 mm dia. R.C.C. pipe	meter	5.00	2447.33	12237.00
27	Brick work with common burnt clay F.P.S. (non modular) bricks of class designation 7.5 in foundation and plinth in Cement mortar 1:4 (1 cement : 4 coarse sand)	Cum	17.30	5228.53	90454.00
28	Finishing with 12mm thick cement plaster 1:4 (1 cement: 4 fine sand)	Sqm	79.20	218.82	17331.00
29	Finishing walls with water proofing cement paint of required shade on New work (Two or more coats applied @ 3.84 kg/10 sqm)	Sqm	79.20	74.83	5927.00
30	Random rubble masonry with hard stone in foundation and plinth including levelling up with cement concrete 1:6:12 (1 cement : 6 coarse sand : 12 graded stone aggregate 20 mm nominal size) upto plinth level with Cement mortar 1:6 (1	cum	84.30	5019.06	423127.00
TOTAL AMOUNT OF WORKS (I) (Rs)					70,929,796.00
II	4 Nos. OF 2.5 LAKH LITRE CAPACITY UNDERGROUND RCC WATER TANK	UNIT	QTY	ITEM RATE (Excluding GST)	Amount in Rs.
1	Earth work in excavation by mechanical means (Hydraulic excavator) /manual means over areas (exceeding 30cm in depth. 1.5 m in width as well as 10 sqm on plan) as per required level/camber/gradient including, rolling and compacting the cut surface to achieve 95% or more of standard proctor's MDD , disposal of excavated earth, lead upto 5Km and lift upto 1.5m, disposed earth to be levelled and neatly dressed. (All kinds of soil)	Cum	2966.00	149.12	442289.92
2	Earth work in excavation by mechanical means (Hydraulic excavator)/ manual means over areas (exceeding 30 cm in depth, 1.5 m in width as well as 10 sqm on plan) including getting out and disposal of excavated earth lead upto 5Km and lift upto 1.5 m, as directed by Engineer-in-charge. Ordinary rock	Cum	5.00	289.01	1445.05
3	Filling available excavated earth (excluding rock) in trenches, plinth, sides of foundations etc. in layers not exceeding 20cm in depth, consolidating each deposited layer by ramming and watering, lead up to 5Km and lift upto 1.5 m.	Cum	2003.30	180.11	360814.36
4	Providing and laying in position cement concrete of specified grade excluding the cost of centering and shuttering - All work up to plinth level : 1:2:4 (1 cement : 2 coarse sand (zone-III) : 4 graded stone aggregate 20 mm nominal size).	Cum	58.28	5566.65	324396.53
5	Providing and laying in position machine batched and machine mixed design mix M-30 grade cement concrete for reinforced cement concrete work for water retaining tanks, using cement content as per approved design mix, including pumping of concrete to site of laying but excluding the cost of centering, shuttering, finishing and reinforcement, including plasticiser cum water proofing cement additives in recommended proportions as per IS: 9103 to accelerate, retard setting of concrete, improve workability without impairing strength and durability as per direction of Engineer-in-charge.	Cum	488.29	6946.24	3391779.53

UNPRICED PRICE BID (GSECL 100MW RAGHANESDA PH-II)

CONSTRUCTION OF ROADS, DRAINS, CULVERT AND 4 Nos OF 2.5 LAKH LITRES CAPACITY UNDERGROUND RCC WATER TANK FOR 100 MWp SOLAR PV PLANT FOR GSECL, RAGHANESDA PHASE-II

Sl.no	DESCRIPTION	UNIT	QTY	ITEM RATE (Excluding GST)	Amount in Rs.
6	Providing and mixing integral crystalline admixture for waterproofing treatment to RCC structures like basement raft, retaining walls, reservoir, sewage & water treatment plant, tunnels / subway and bridge deck etc. at the time of transporting of concrete into the drum of the ready-mix truck, using integral crystalline admixture @0.80% (minimum) to the weight of cement content per cubic meter of concrete) or higher as recommended by the manufacturer's specification in reinforced cement concrete at site of work. The material shall meet the requirements as specified in ACI-212-3R-2010 i.e.by reducing permeability of concrete by more than 90%,compared with control concrete as per DIN 1048 and resistant to 16 bar hydrostatic pressure. The crystalline admixture shall be capable of self-healing of cracks up to a width of 0.50mm. The work shall be carried out all complete as per specification and the direction of the Engineer-in-charge. The product performance shall carry guarantee for 10 years against any leakage. water proofing by FOSROC or PIDILITE, SIKA	Kg	1562.53	317.50	496102.64
7	Steel reinforcement for R.C.C. work including straightening, cutting,bending, placing in position and binding all complete upto all level. Thermo-Mechanically Treated bars of grade Fe-415 CRS .	Kg	39063.20	68.47	2674657.30
8	Centering and shuttering including strutting, propping etc. and removal of form for all heights : Foundations, footings, bases of columns, etc. for mass concrete.	sqm	133.20	233.58	31112.86
9	Centering and shuttering including strutting, propping etc. and removal of form for all heights : Walls (any thickness) including attached pilasters, buttersesses, plinth and string courses etc.	Sqm	1051.44	499.63	525330.97
10	Centering and shuttering including strutting, propping etc. and removal of form for all heights : Suspended floors, roofs, landings, balconies and access platform.	Sqm	441.80	568.30	251074.94
11	Centering and shuttering including strutting, propping etc. and removal of form for all heights :Lintels, beams, plinth beams, girders, bressumers and cantilevers	Sqm	64.80	452.68	29333.66
12	12 mm cement plaster finished with a floating coat of neat cement of mix : 1:4 (1 cement: 4 fine sand)-Internal Plaster.	Sqm	1356.72	269.17	365188.32
13	12 mm cement plaster of mix : 1:4 (1 cement: 4 fine sand)-External Plaster.	Sqm	582.16	218.82	127388.25
14	Applying one coat of water thinnable cement primer of approved brand and manufacture on wall surface : Water thinnable cement primer.	Sqm	1938.88	49.20	95392.90
15	Finishing walls with water proofing cement paint of required shade : New work (Two or more coats applied @ 3.84 kg/10 sqm)-Make asian ace paint.	Sqm	1938.88	74.83	145086.39
16	Painting with black anti-corrosive bitumastic paint of approved brand and manufacture to give an even shade : Two or more coats on new work Make Berger/Asian paints.	Sqm	582.16	86.96	50624.63
17	Structural steel work riveted, bolted or welded in built up sections,(such as supply & fixing of CI rung work & puddle pipe work req. dia) including cutting, hoisting, fixing in position and applying a priming coat of approved steel primer all complete.	kg	1000.00	83.44	83440.00
18	Painting with synthetic enamel paint of approved brand and manufacture to give an even shade : Two or more coats on new work .Make-Berger/Asian paints.	Sqm	100.00	99.67	9967.00
19	Providing and Placing in position suitable PVC water stops conforming to IS:12200 for construction/ expansion joints between two RCC members and fixed to the reinforcement with binding wire before pouring concrete etc. complete : Serrated with central bulb (225 mm wide, 8-11 mm thick).	meter	250.00	232.22	58055.00
20	Water supply for tank leakage test. Filling the tank with 250000 Litre water and keep it for 24 hrs.	5000L	200.00	738.00	147600.00
21	Hire charges of Pump set of capacity 4000 litres/hour for draining out the water after leakage test.	day	30.00	574.00	17220.00

UNPRICED PRICE BID (GSECL 100MW RAGHANESDA PH-II)

CONSTRUCTION OF ROADS, DRAINS, CULVERT AND 4 Nos OF 2.5 LAKH LITRES CAPACITY UNDERGROUND RCC WATER TANK FOR 100 MWp SOLAR PV PLANT FOR GSECL, RAGHANESDA PHASE-II

Sl.no	DESCRIPTION	UNIT	QTY	ITEM RATE (Excluding GST)	Amount in Rs.
22	Providing and applying of swellable type water stop tape, 19mm x 25mm thick in linear meter (expansive nature) for construction joints treatment of RCC structure, such as raft slab, retaining walls, water storage tank and at the junctions of raft slab with the retaining walls etc.. After cleaning the surface, one coat of required primer for swellable water stop tape shall be applied throughout the length of the joint @3.78 litre per 240 running meter. Over the primed surface swellable type water stop tape shall be placed. The work shall be carried out all complete as per specification and the direction of the engineer-in-charge. The product performance shall carry guaranteed for 10 years against any leakage.	meter	250.00	452.80	113200.00
23	Providing and fixing Chlorinated Polyvinyl Chloride (CPVC) pipes, having thermal stability for hot & cold water supply including all CPVC plain & brass threaded fittings This includes jointing of pipes & fittings with one step CPVC solvent cement, trenching, refilling & testing of joints complete as per direction of Engineer in Charge:				
a	40 mm nominal outer dia Pipes	meter	20.00	440.14	8802.80
b	100 mm nominal inner dia Pipes	meter	20.00	2279.23	45584.60
c	150 mm nominal inner dia Pipes	meter	20.00	4773.92	95478.40
24	Supplying and filling with stone dust as CNS filling material below tank raft, including watering, ramming, consolidating and dressing complete.	cum	555.00	902.00	500610.00
25	Rubble soling 230 mm thick including supply of stones, compaction, filling of voids, preparing surface etc complete in all respect and as per direction of Engineer-in-charge.	Sqm	555.00	598.76	332311.80
TOTAL AMOUNT OF WORKS (II) (Rs)					10,724,288.00
TOTAL AMOUNT OF WORKS (I+II) (Rs)					81,654,084.00
QUOTE PERCENTAGE (%) ABOVE/BELOW (+/-) (OR) AT PAR TO TOTAL AMOUNT					XXXXXXXX
QUOTED PERCENTAGE (%) IN WORDS ABOVE/BELOW (OR) AT PAR TO TOTAL AMOUNT					XXXXXXXX
Plus applicable GST					
NOTE:					
1. CONTRACTOR SHOULD QUOTE PERCENTAGE (%) ABOVE/BELOW (OR) AT PAR TO TOTAL AMOUNT					
2. QUOTED PERCENTAGE (%) IS APPLICABLE ON ALL ITEM RATES UNIFORMLY.					



TECHNICAL AND GENERAL SPECIFICATION

The all material, installations, fixtures, accessories etc. to be provided shall be as per the relevant I.S. specifications. These shall be of best quality and of standard manufacturer as approved by the EIC, when there are no standard specifications. The fresh OPC/PPC cement and TMT steel reinforcement bars Fe 415 CRS shall be used confirming to relevant I.S Specifications of the approved manufacturers of GSECL. The agency has to keep the full proof records of purchase and consumption along with original purchase bills of Cement and Steel as per the GSECL procedures and rules. The agency has to provide best workmanship with skilled manpower for all the civil items as per the standard specifications/ best practice as approved by the EIC. The booklet Standard Specifications for Civil Works will be applicable wherever there is dispute in the items of civil works. GSECL will not supply any material for this work.

Topographical Survey: Topographical survey shall have to be done by the Contractor of the proposed site at 5 m interval with the help of Total Station or any other suitable standard method of survey. All necessary Reduced Levels (RL) as entered in the Field Book/Soft Copy have to be submitted along with pre contour layout of the total site. The formation levels of the proposed power plant have to be fixed with reference to High Flood Level of the proposed site. The ground level and plinth level of structures shall be fixed taking into consideration the highest flood level and surrounding ground profiles.

Soil Test: Company has provided soil test report in Annexure-A5 which is meant to indicate kind of soil condition site may have and Contractor shall treat it accordingly. Contractor is advised to and is solely responsible to carry out detailed Geotechnical investigation to ascertain soil parameters of the proposed site for the use of planning / designing / construction / providing guarantee / warranty of all civil work including but not limited to foundations / piling for module mounting structures, HT lines, 66 kV switchyard equipment etc. The Contractor shall carry out soil investigation through either KCT (Ahmedabad), MK soil(Ahmedabad) and Unique Lab(Surat) and NABL accredited labs. These reports shall be furnished to the Company prior to commencing work. All RCC works shall be provided of required grade of concrete as per relevant IS specifications as well as soil data considering appropriate earthquake seismic zone, wind velocity, whether effect, soil characteristics etc.

The scope of soil investigation covers execution of complete soil exploration including boring, drilling, collection of undisturbed soil sample where possible, otherwise disturbed



soil samples, conducting laboratory test of samples to find out the various parameters mainly related to load bearing capacity, ground water level, settlement, and soil condition and submission of detail reports along with recommendation regarding suitable type of foundations for each bore hole along with recommendation for soil improvement where necessary. The design will done based on considering the worst result among the bore holes. Contractor has to carry out also Electrical Resistivity Test.

The Contractor shall carry out Shadow Analysis at the site and accordingly design strings and arrays layout considering optimal use of space, material and man power and submit all the details / design to Company for its review / suggestions /approval.

The Contractor shall obtain and study earthquake and wind velocity data for design of module mounting structure, and considering all parameters related to the weathers conditions like Temperature, humidity, flood, rainfall, ambient air etc.

The foundations should be designed considering the weight and distribution of the structure and assembly, and a maximum wind speed of 180 Km per hour for the site have to be considered while making the design of the foundation. Successful Bidder shall also plan for transport and storage of materials at site and shall arrange for its own construction power and water. However, the Contractor can avail construction power connection from Discom by applying for temporary connection and has to borne all cost for the same. Client will help for supporting documents. However, the Contractor can avail construction water from concern Solar Park Authority and pay for the same at the prevailing existing rates for the usage of water.

The Bidder shall estimate the water requirements for cleaning the photovoltaic modules at least once in every week in order to operate the plant at its guaranteed plant performance.

Prefabricated structures for control room and inverter rooms shall be strictly as per relevant IS standards.

Land Development and Cleaning: Site is found to be more or less flat. However, the Contractor shall visit the site to ensure the land development work and do the topographical survey to ensure land development work such that land is perfectly flat. The Contractor has to clean the site from small trees and shrubs; removal of debris, if any; filled the depression area and excavates and level the high level areas wherever required even though contractor follows the natural ground level for entire plant execution. The Contractor can also use the



natural contour of the land, if shadow is not affecting the generation. However, the Contractor shall take reasonable care to ensure that the plant is aesthetically designed.

Storm Water Drainage System: The Contractor has to design, submit and take approval from the Client/Consultant for storm water of the plant. It shall be designed in a such way that it can be easily drain off rain water and water required for module cleaning by providing sufficient slope. Storm water drain shall be of Trapezoidal section. Storm water drain should be paved by 50 mm thick concrete lining in c.c. 1.:2:4 & 75 mm thick bedding in c.c. 1 : 4 : 8 with Manhole chamber and R.C.C.cover. Necessary arrangement is to be made for disposing of storm water at end by naturally or lifting of water by pump or any mechanical arrangement out side the plant.

All other internal drains i.e. on both side of central road, pathways to inverter room, control room, switchyard are to be done by simply excavating and by carrying out dressing and maintaining the side slope of the drain of required size and with required trapezoidal section in which no brick pitching is required. Also, the Contractor shall provide RCC home pipe (NP3 grade) at the crossing of road and drains and at required locations. And also necessary arrangement for disposing / lifting of accumulated surface water is to be made by providing pump and RCC sump of required capacity is to be made by agency as per site requirement.

Security Cabin: The Contractor shall provide 4 (four) numbers of prefabricated Watchman's portable cabin at minimum 4 (four) corners of the boundary of each plant such that safety of the plant is ensured along with one Watchman's cabin at the Main Gate of the plant as mentioned in the Clause 5.1.5. The minimum size of watchmen's (Security Cabin) cabin is 1.2 metre x 1.8 metre size and height of 2.4m with appropriate roof at the top. Location of the watch Cabin (Security Cabin) will be as directed by GSECL.

Area lighting arrangement shall be made to illuminate the entire site at an appropriate lug level for night hours or bad light hours. Road and Perimeter LUX level min 10 and rest area as per NBC 2016. Area lighting arrangement shall have adequate numbers of lights poles on the sides of roads, periphery, etc.

The connector box shall be made of stainless steel, Dust & Vermin Proof, which is to be recessed at the base of each Yard Lighting system. The connector box shall have suitable brass or copper made connector terminal.



The lighting fixtures with control gear shall be mounted on tubular poles of approved height and mounting arrangement.

All the yard lighting towers and lighting fixtures shall be effectively grounded using adequate size of GI earthing wires / GI earthing strips.

The light pole shall be fixed in separate foundation. The lighting poles shall be concreted with 600 mm coping above ground level for pole protection and 1 m below ground with minimum reinforcement as per IS requirement.,.

The control gear box (non-integral type) shall be encased in the coping.

Loop in – Loop out power cables shall be brought up to the control gear box through of adequate size for cable protection.

The cables shall be properly glanded to the control gear box gland plate.

XLPE / PVC insulated armored Cu/Al cables of adequate size shall be used for interconnection and supply of power to Yard lighting systems.

Cable terminations shall be made with suitable cable lugs & sockets etc. crimped properly and passed through brass compression type cable glands at the entry & exit point of the connector box and at the entry point to MCB distribution Box for controlling the yard lighting system.

The height of the area lighting fixtures should not exceed 2.0 meters from ground. Lighting fixtures shall be installed close to fencing.

Fencing: Plant shall be protected by PVC coated chain link fencing. The minimum height of the fencing shall be 2.00 mt. above ground. The chain link of 50mm x 50mm diamond mesh of 10 gauge galvanized steel wire with 12 gauge barbed wires at top (3 numbers) is to be provided. Providing and fabricating and fixing aligning vertical post of 75mm x 75mm x 6mm with cross bracing both side of ISA 45mm x 45mm x 5mm and 40mm x 6mm G.I. flat is to be provided. Also line wire at top and bottom of chain link mesh of 8 gauges is to be provided as per drawing. The detail drawing of the Fencing is attached. Contractor has to strictly follow the drawing for implementation.

Watchman's Cabin and Main Entrance Gate



An all-weather main gate with width of at least 6 meter shall be erected at the entrance of the plant site.

The Prefabricated Security Cabin of size 3.5 metre x 3.5 metre at the main entrance gate shall be designed in the Bid document and constructed by the Successful Bidder keeping in view the safety and security of the power plant.

The Bidder shall provide detailed civil, electrical, plumbing, etc. drawings and equipment specifications for the security cabin in “(B) Technical Offer” of the Bid document.

Roads: The Contractor has to design as per relevant IS, submit and take approval from the Company /Consultant for Asphalt roads. All the roads connecting the main gate to control room, switch yard and inverter room shall be accessed by Asphalt road with sufficient base courses like WBM layer, Wet Mix layer, WBM layer and at top Seal Coat. Asphalt road width shall be of 4mtr plus shoulder and with sufficient thickness to access heavy equipment like transformers/inverters/switchyard equipment transportation.

Underground RCC water Tank: The Contractor has to design as per relevant IS codes, submit and take approval from client / consultant and construct 5 lacs liter (2 x 2.5 lacs litre) underground RCC water tank for each plot with silting chamber for filtration of the water before the inlet which will match with invert level of Storm Water drain. Design of RCC water tank shall be such that it shall resist Earth pressure and Water pressure and satisfy all IS codes. Design of water tank shall be done strictly based on Soil Investigation Report with complying all latest IS codes.

Water supply: All necessary arrangement for wet cleaning of the solar panels shall be in the scope of the bidders and accordingly the agency has to provide all the necessary equipment, accessories, tool & tackles, pumps, tankers, tractors and piping arrangement which are required for the same.

Pre-fab Inverter/Pre-fab Control cum Conference Room

Civil work for Pre-fab Inverter Room/Pre-fab Control cum Conference room shall be of adequate size and of be of standard manufacturer with sufficient lighting points and RCC cable trenches with oil painted edge angle of 65mm x 65mm x 6mm and checker plate covers of 8 mm thickness and shall have exhaust chimney and also sufficient ventilation. All prefab inverter room and Control cum Conference Room shall be laid on RCC plinth with sufficient foundation and reinforced grade slab with finished Kotah of 25mm thickness /Vitrified of 8-10mmthickness tile flooring and 100 mm skirting of same tiles. The plinth shall be minimum 600 mm high from formation level of the plant. Plinth protection shall be given throughout perimeter of width 1.2m with rough kotah of 25mm



thickness on its top for Inverter rooms and Control cum Conference Rooms. Sufficient steps at the entry of the room with rough Kotah on its top and RCC ramp of sufficient angle shall be provided for shifting the equipment in the rooms for all Inverter rooms and Control cum Conference Room. Rainwater pipe at various locations with gutter at the top shall be provided to discharge rainwater.

i. RCC frame structure below plinth for Inverter Rooms/Control cum Conference Room shall have adequate size of footing, pedestal columns, plinth beam, grade slab with reinforcement as per relevant IS specifications considering seismic zone, wind and soil detail etc. Backfilling material shall be of Laboratory tested Murram or sand. Grade slab shall be laid on 100mm thick PCC. Also, Termite proofing is required before preparation of grade slab and plinth protection. The Control cum Conference Room shall have a rolling shutter at the front side.

ii. Control cum Conference room shall be of adequate size (minimum height 3.6 mtr) for fixing the panels, battery banks etc. With a) Conference room; b) SCADA Room with Work station with Desktop and Chairs; c) Store Room with almirah; d) Pantry unit of sufficient size with sandwich type of platform with plumbing fixture and exhaust fan; e) Toilet unit for Gents with urinals and Ladies having wash basins in each; f) RCC cable trenches with covers and cable trays and all openings of cable entry shall have vemin proofing using spray foam or mortar; g) Furniture like conference table, chair and sofa etc.; h) Lighting points and fixtures; and i) Plumbing fixtures.

Facilities required for Control cum Conference Room: It shall also have adequate size SCADA cabin with necessary 2 numbers of work station with drawers of Godrej/ Durian/ Zuari make, 2 numbers Computer and 1 number of LED TV of 48 inch of Sony/ Phillips / Samsung make, 4 numbers of chairs for workstation, 2 Nos. of almirah and split A.C of 1.5 Ton of Voltas/ Hitachi/ Samsung/LG make for operating staff for work station. Conference Room shall also be equipped with conference table of 10 persons with Power Sockets with 10 chairs of Godrej/Durian/Zuari/Usha/ Lexus and sofas. In Control cum Conference room, except control room (where panels are fixed) all other rooms like SCADA cabin, conference room, store, pantry and passage shall have False ceiling that shall consist of 600 x 600 x 20 mm gypsum board with one coat of primer and two or more coat of Acrylic emulsion paint. The suspension system shall consist of 6 mm diameter galvanized steel rods suspended from ceiling supporting by aluminum grid of 38 x 25 x 1.5 mm and cross tie of 25 x 25 x 1.5 mm and aluminum angle of 25 x 25 x 1.5 mm. Conference room shall be equipped with an all-in-one printer cum scanner, landline phone, refrigerator (150 litre) of Voltas/Godrej/Whirlpool make, projector and screen of 2m x 2m. All material,



installations, accessories to be provided shall be of best quality and of standard manufacturer as approved by the EIC/ the Company. All units of the Control cum Conference Room shall have marked signage of SS sheet of 1mm along with engraving words and filled with black color at all facilities within Control cum Conference room and on all equipment. The lighting points and fixtures shall be of Anchor/Philips make. The fans shall be of Khaitan/Usha/Bajaj make and lights (only LED shall be used) shall be of Philips/Syska/Havells make.

Structural Steel, Insulated Walls and Roof for Super structure:

Design of Super-Structure i.e. Steel Structure like purlin, rafter, columns, truss etc. for fixing the Pre-Fabricated Panels conforming to relevant IS codes and of Jindal/ Tata/ RINL make. It shall include all necessary fitting like nuts, bolts, washers etc. of good quality. All structural steel shall be treated with two coats of red oxide and three coats of Oil paint (Asian Paints, Berger, Durex). The gap between base plate of structural members and concrete top of foundation shall be filled with GP-2 grouting material of reputed make. The material of all J-bolts shall be of 8.8 Class.

The Insulated panels should be of required size for roof and walls. The insulated wall and roof panels shall be sandwich type. The panels shall be made out with 0.35mm thick pre coated steel sheet on both side of Poly Urethane Foam (PUF) for both wall and roof. The density of PUF shall be 40 ± 2 kg/m³ and thermal conductivity shall be within range of 0.019-0.021 W/m[°] K at 10[°] C. The total thickness of the panels for walls shall be 60mm and for roof is 40mm. The panels shall be joined together by tongue and groove method. The joints of the panels shall be filled with silicon or equivalent filling material. Panels shall be cuts such that the exposure of PUF and patch work is avoided. The fixing of the panels shall be such that there should not be any gaps at joints like wall and roof, wall to wall, etc. from which air and water particle can pass (Air and Water tight). Roof panel shall be extended 300mm from the eaves wall and 150mm from Gable walls. Rain water gutter shall be provided throughout the periphery with rain water pipes (CPVC pipes) with proper clamping at regular interval. Provision of future installation of Solar panels on the top of the roof shall be done by I or C section with Small base plate assembly.

Landscaping: Landscaping in surrounding area of 2 meter of MCR is to be done using aesthetically pleasing and suitable varieties of flora.

Electrical requirements for Control cum Conference Room:

The Panels shall have adequate inputs to take in from the centralized Push Button Switching Unit having Suitable Mimic with Power flow Indicator & Status Indicator of different PCU's.



The Panel shall be floor mounted type. All the measuring instruments such as feeder voltmeter, ammeter, frequency meter, Electronic Energy Meter (for measuring the deliverable units (kWh) for sale), selector switches, Mimic etc. shall be in the front panel.

All the Power cables shall be taken through backside of the Panel via sufficient /concrete cable trench and cable trays with cover at top.

The Panel shall be fitted with suitable rating & size, HRC fuses/circuit breaker/isolator indicators for all incomer and outgoing terminals, voltmeter & ammeter with suitable selector switches to monitor & measure the power to be evacuated.

Nuts & bolts including metallic cubicle shall have to be adequately protected against atmosphere and weather prevailing in the area.

The overall dimension shall be fitted with other Power Conditioning Units of the Power Plant. However, dimension, weight, sheet thickness, painting etc. should be indicated by the Bidder. The bill of material associated with the equipment should be clearly indicated while delivering the equipment.

The Contractor shall provide to the Company detailed civil, electrical, plumbing, etc. drawings and equipment specifications for the inverter/ control room and take approval from client/consultant. The drawings of Panels with the make of components should be approved from the Company.

All the design & drawing related to switch yard / interconnection with grid should be as per requirement of GETCO and approved from GETCO.

Pre-fab structure shall have sufficient number of lighting point/ACDB/MCB board.

Flooring: Best quality Vitrified tile flooring having min size of 600 mm x 600 mm x 8-10 mm thickness of standard manufacturers as approved by EIC.

Toilet: Toilet shall be designed for 10 persons; and constructed with following finish

- Floor: Vitrified tiles
- Door and window: made out of aluminum sections, 6mm float glass
- Ventilators : Mechanical exhaust facility
- Plumbing fixtures : Jaquar and Kohler make
- Sanitary ware : Hindware, Cera or equivalent make
- EWC : 390 mm high with health facet, toilet paper roll holder and all fittings
- Urinal (430 x 260 x 350 mm size) with all fittings.
- Wash basin (550 x 400 mm) with all fittings.
- Bathroom mirror (600 x 450 x 6 mm thick) hard board backing
- CP brass towel rail (600 x 20 mm) with C.P. brass brackets
- Soap holder and liquid soap dispenser.



Doors and Windows: Doors and windows shall be made of aluminum sections. All sections shall be 20 microns anodized. Sections of door frame and window frame shall be adopted as per industrial standards. Door shutters shall be made of aluminum sections and combination of compact sheet and clear float/wired glass. All windows of Control cum conference room shall be protected by Sun film protection sheet. The control room shall require a number of windows/louvers to provide ventilation/ fresh air circulations. All fixtures for doors and windows shall be of Dorma, Godrej and Kich make.

Water Supply for Toilets: GI pipes (B class) Tata or equivalent make. Separate Overhead water tank Sintex or equivalent of 2,000 litre capacity.

Drainage for Toilets: Drainage pipes shall be of CPVC (6 kg/cm²) Supreme, Prince or equivalent make. Gully trap, inspection chambers, septic tank for 10 person and soak well to be constructed for abovementioned requirement.

Air Conditioner for Control Room: The control room shall be equipped with appropriate numbers of fans for effective heat dissipation. The SCADA cabin and Conference room shall have split type air conditioning units.

Fire Extinguishers: Liquefied CO₂ fire extinguisher shall be upright type of capacity 10 kg having IS: 2171. 7 IS: 10658 marked. The fire extinguisher shall be suitable for fighting fire of Oils, Solvents, Gases, Paints, Varnishes, Electrical Wiring, Live Machinery Fires, and All Flammable Liquid & Gas. Bidder shall provide 10 no. of portable fire extinguisher as given below.

Sand Bucket: Sand buckets should be wall mounted made from at least 24 SWG sheet with bracket fixing on wall conforming to IS 2546. Bucket stands with four buckets on each stand shall be provided in the Transformer Yard – 4 Nos.

Sign Boards: The sign board containing brief description of various components of the power plant as well as the complete power plant in general shall be installed at appropriate locations of the power plant.

- For Switchyard and Transformer Yard: The Signboards shall be made of steel plate of not less than 3 mm. Letters on the board shall be with appropriate illumination arrangements.
- All Inverter Rooms and Control and Conference Room: The name boards shall be made of acrylic sheet of 300mm height and fixed at the entry of the all facilities.



- The Contractor shall provide to the Company, detailed specifications of the sign boards.
Module Mounting Structures (MMS)
 - i. The MMS should be designed for an optimum tilt angle (fixed / season / single axis tracking) so as to meet the offered NEEGG. The angle should be systematically optimized for maximum energy generation throughout the year based on location and local weather variables for each module technology.
 - ii. The MMS should be safe, and designed to allow easy replacement of any module and easy access to the O&M staff. It should be designed for simple mechanical and electrical installation, should support Solar PV modules at a given orientation, absorb and transfer the mechanical loads to the ground properly and there should be no requirement of welding or complex machinery at site.
 - iii. The array structure shall be so designed that it will occupy minimum space without sacrificing the output from Solar PV panels at the same time it will withstand severe cyclonic storm with wind speed up to maximum 180 Kmph.
 - iv. It shall support Solar PV modules at a given orientation, absorb and transfer the mechanical loads to the ground properly. There shall be no requirement of welding or complex machinery at site and is strictly not allowed.
 - v. Seismic factors for the site to be considered while making the design of the foundation/ramming etc. Or any technology. The design of array structure shall be based on soil test report of the site and shall be approved from the Company/Consultant.
 - vi. The Contractor has to plan for pilot test like pull out, lateral and compression of minimum 10,10,3 are required to be conducted for each floor at strategic location, immediately after receiving LoI. Based on the results of above-mentioned tests, final approval for design of pile shall be provided.
 - vii. Modules shall be mounted on a non-corrosive support structures (EPDM rubber gasket is to be provided as separator) which is mandatory. The frames and leg assemblies of the array structures shall be made of hot dip Galvanized steel per ASTM A123.
 - viii. In case of galvanization of structures, specific requirement for thickness of galvanization should be at least minimum 80 microns at any point of the galvanized structure. Galvanization shall be measure with elcometer or the material can be sent for testing laboratory as and when required. No averaging is allowed for measuring the thickness of galvanization. Inner side galvanization with same specification of any hollow components of module mounting structure is mandatory.
 - ix. All nuts and bolts shall be of SS type for module structure connection and for other structures, superstructure or switchyard, inverter room, control room, etc. in the plant premises bolts shall be of minimum Grade HDG: 8.8 according to the connection design requirement..
 - x. Modules shall be clamped / bolted with the structure properly. The material of



- construction shall be Al / Steel. Clamps / bolts shall be designed in such a way so as not to cast any shadow on the active part of a module.
- xi. Modules shall be isolated electrically from the MMS through EPDM sheet of appropriate thickness and all the modules shall be separately earthed through proper earthing. Module to module earthing is mandatory.
 - xii. Module mounting structures shall also be earthed through proper separate earthing.
 - xiii. The material of construction, structural design and workmanship shall be appropriate with a factor of safety of not less than 1.5.
 - xiv. For multiple module mounting structures located in a single row, the alignment of all modules shall be within an error limit of 5 mm in vertical / horizontal line.
 - xv. The Contractor shall provide to the Company the detailed design, specifications and calculations of the MMS and take approval from the Company/Consultant.
 - xvi. The Contractor shall specify installation details of the Solar PV modules and the support structures with appropriate diagrams and drawings.
 - xvii. The Module Mounting Structure design shall be certified by a chartered structural engineer and it is mandatory.
 - xviii. The Contractor should design the structure height considering highest flood level at the site. The minimum clearance between the lower edge of the module and the ground shall be the higher of (i) above highest flood level at the site and (ii) minimum 500mm. String Cables should be passed from Pipes and Cable-ties shall be used to hold and guide the Pipes (cables/wires) from the modules to inverters or junction boxes.
 - xx. The Contractor shall provide to the Company the detailed design, specifications and calculations of the MMS.
 - xxi. Curing of all piles shall be done thrice a day and be maintained for a period of seven days from the date of casting.
 - xxii. The Contractor has to ensure sufficient lighting arrangement for all concreting activities during night time. Sufficient illumination should be ensured in and around areas wherever civil and construction activities take place during night time.
 - xxiii. The Contractor shall specify installation details of the Solar PV modules and the support structures with appropriate diagrams and drawings.
 - xxiv. The Bidder shall be permitted ramming of the module mounting structure provided that they obtain consent of EIC. EIC shall provide such consent once it is convinced that such ramming shall not in any way deteriorate the strength of the structure and shall not reduce the structure's strength to enjoy a working life of more than 25 years.
 - xxv. Civil foundation design for Module Mounting Structures (MMS) as well as control room, inverter room shall be made in accordance with the Indian Standard Codes and soil conditions, with the help of Chartered Structural Designer having substantial experience in



similar work. The Successful Bidder shall submit the detailed structural design analysis along with calculations and bases/ standards in the Bid.

xxvi. Module Mounting Structures Design is to be certified by Chartered Structure Engineer and certificate to be produced along with the design details for approval by GERM / GSECL.

Switchyard structures / transmission line structure designs shall be strictly as per GETCO design.



GENERAL CONDITIONS OF CONTRACT

2019

ಭಾರತ್ ಹೆವಿ ಎಲೆಕ್ಟ್ರಿಕಲ್ಸ್ ಲಿಮಿಟೆಡ್, ವಿದ್ಯುನ್ಮಾನ ವಿಭಾಗ, ಬೆಂಗಳೂರು
भारत हेवी इलेक्ट्रिकल्स लिमिटेड, इलेक्ट्रॉनिक्स डिवीज़न, बेंगलुरु
Bharat Heavy Electricals Limited, Electronics Division, Bengaluru

CONTENTS

Chapter-1

1. General Instructions to Tenderers

1.1. Dispatch Instructions

1.2. Submission of Tenders

1.3. Language

1.4. Price Discrepancy

1.5. Evaluation of Bids

1.6. Data to be enclosed

1.7. Authorisation and Attestation

1.8. Earnest Money Deposit

1.9. Security Deposit

1.10. Return of Security Deposit

1.11. Bank Guarantee

1.12. Validity of offer

1.13. Execution of Contract Agreement

1.14. Rejection of Tender and other Conditions

1.15 BHEL Fraud Prevention Policy

2. Chapter-2

2.1. Definitions

2.2. Law Governing Contract and Court Jurisdiction

2.3. Issue of Notice

2.4. Use of land

2.5. Commencement of Work

2.6. Measurement of Work and Mode of Payment

2.7. Rights of BHEL

2.8. Responsibilities of Contractor in respect of Local Laws, Employment of Workers etc

2.9. Progress Monitoring, Monthly Review and Performance Evaluation

2.10. Time of Completion

2.11. Extension of Time for Completion

2.12. Over Run Compensation

2.13. Quantity Variation

2.14. Extra Works

2.15. Supplementary Items

2.16. Strikes & Lockout

2.17. Force Majeure

2.18. Arbitration and Reconciliation

2.19. Payments

2.20. Performance Guarantee for Workmanship

2.21. Closing of Contracts

2.22. Reverse Auction

2.23. Suspension of Business Dealings

2.24. Other Issues

CHAPTER -1

1. GENERAL INSTRUCTION TO TENDERERS

1.1. DESPATCH INSTRUCTION

i) The General Conditions of Contract form part of the Tender specifications. All pages of the tender documents shall be duly signed, stamped and submitted along with the offer in token of complete acceptance thereof. The information furnished shall be complete by itself. The tenderer is required to furnish all the details and other documents as required in the following pages

ii) Tenderers are advised to study all the tender documents carefully. Any submission of tender by the tenderer shall be deemed to have been done after careful study and examination of the tender documents and with the full understanding of the implications thereof. Should the tenderers have any doubt about the meaning of any portion of the Tender Specification or find discrepancies or omissions in the drawings or the tender documents issued are incomplete or shall require clarification on any aspects, the scope of work etc., he shall contact the authority inviting the tender well in time (so as not to affect last date of submission) for clarification before the submission of the tender. Tenderer's request for clarifications shall be with reference to Sections and Clause numbers given in the tender documents. The tender specifications and terms and conditions shall be deemed to have been accepted by the tenderer in the offer. Pre requirements and conditions shall be liable for rejection.

iii) Integrity pact (IP): If NIT calls for Integrity Pact, the same shall be duly signed & stamped by the authorised signatory & submitted along with tender document.

1.2. SUBMISSION OF TENDERS

1.2.1 The tenderers must submit their tenders as per instructions in the NIT

1.2.2 BHEL takes no responsibility for delay, loss or non-receipt of tenders sent by post/courier. The tenders received after the specified time of their submission are treated as 'Late Tenders' and shall not be considered under any circumstances. Offers received by Fax/Email/Internet shall be considered as per terms of NIT.

1.2.3 Tenders shall be opened by authorised Officer of BHEL at his office at the time and date as specified in the NIT, in the presence of such of those tenderers or their authorised representatives who may be present

1.2.4 Tenderers whose bids are found techno commercially qualified shall be informed the date and time of opening of the Price Bids and such Tenderers may depute their representatives to witness the opening of the price bids. BHEL's decision in this regard shall be final and binding.

1.2.5 Before submission of Offer, the tenderers are advised to inspect the site of work and the environments and be well acquainted with the actual working and other prevalent conditions, facilities available, position of material and labour, means of transport and access to Site, accommodation, etc. No claim will be entertained later on the grounds of lack of knowledge of any of these conditions.

1.3. LANGUAGE

1.3.1 The tenderer shall quote the rates in English language and international numerals. These rates shall be entered in figures as well as in words. For the purpose of the tenders, the metric system of units shall be used.

1.3.2 All entries in the tender shall either be typed or written legibly in ink. Erasing and over-writing is not permitted and may render such tenders liable for rejection. All cancellations and insertions shall be duly attested by the tenderer.

1.4 PRICE DISCREPANCY:

1.4.1 Conventional (Manual) Price Bid opening:

i) If, in the price structure quoted for the required goods/services/works, there is discrepancy between the unit price and the total price (which is obtained by multiplying the unit price by the quantity), the unit price shall prevail and the total price corrected accordingly, unless in the opinion of BHEL there is obvious misplacement of decimal point in the unit price, in which case the total price as quoted shall govern and the unit price corrected accordingly

ii) If there is an error in a total corresponding to the addition or subtraction of subtotals, the subtotals shall prevail and the total shall be corrected;

iii) If there is a discrepancy between words and figures, the amount in words shall prevail, unless the amount expressed in words is related to an arithmetic error, in which case the amount in figures shall prevail subject of (i) and (ii) above.

iv) If there is such discrepancy in an offer, the same shall be conveyed to the bidder with target date up to which the bidder has to send his acceptance on the above lines and if the bidder does not agree to the decision of BHEL, the bid is liable to be ignored.

v) In case of lump sum price, if there is any difference between the amount in figures and in words, the amount quoted by the bidder in words shall be taken as correct.

vi) *In case of omission in quoting any rate for one or more items, the evaluation shall be done considering the highest quoted rate obtained against the respective items by other tenderers for the subject tender. If the tenderer becomes L-1, the notional rates for the omission items shall be the lowest rates quoted for the respective items by the other tenderers against the respective omission items for the subject job and the 'Total quoted price (loaded for omissions)' shall be arrived at. However the overall price remaining the same as quoted originally, the rates for all the items in the 'Total quoted price (loaded for omissions)' shall be reduced item wise in proportion to the ratio of 'Original' total price and the 'Total quoted price (loaded for omissions)'.*

1.4.2 Reverse Auction: *In case of Reverse Auction, the successful bidder shall undertake to execute the work as per overall price offered by him during the Reverse Auction process. In case of omission of rates, the procedure shall be as per 'Guidelines for Reverse Auction' enclosed.*

i) *Offers from tenderers who are under suspension (banned) by any Unit/Region/Division of BHEL shall not be considered.*

ii) *Offers from tenderers who do not comply with the latest guidelines of Ministry/Commissions of Govt of India shall not be considered.*

1.5. EVALUATION OF BIDS

i) *Technical Bids submitted by the tenderer will be opened first and evaluated for fulfilling the Pre-Qualification criteria and other conditions in NIT/Tender documents, based on documentary evidences submitted along with the offer, BHEL reserves the right to ask for proofs/documents, clarification in relation to Technical/commercial data during tender evaluation*

ii) *Price Bids of shortlisted bidders shall only be opened either through the conventional price bid opening or through electronic Reverse Auction, at the discretion of BHEL*

iii) *Price Bids of unqualified bidders shall not be opened. Reasons for rejection shall be intimated to the vendor before the opening of Price bid.*

1.6. DATA TO BE ENCLOSED

The following information in full shall be furnished by the tenderer. Non-submission of this information may lead to rejection of the offer.

i) *INCOME TAX PERMANENT ACCOUNT NUMBER, GSTIN, SAC, HSN Certified copies of PAN, GSTIN shall be furnished along with tender. The names, addresses and contact information of the Directors/Partners shall be furnished along with the offer.*

ii) *An attested copy of the Power of Attorney, in case the tender is signed by an individual other than the sole proprietor.*

iii) IN CASE OF INDIVIDUAL TENDERER:

His / her full name, address, PAN, GSTIN and place & nature of business to be furnished.

iv) IN CASE OF PARTNERSHIP FIRM

The names of all the partners and their addresses, a copy of the partnership deed/instrument of partnership shall be enclosed.

v) IN CASE OF COMPANIES:

Date and place of registration including date of commencement certificate in case of Public Companies (certified copies of Memorandum and articles of Association are also to be furnished). Nature of business carried on by the Company and the provisions of the Memorandum relating thereof.

1.7. AUTHORISATION AND ATTESTATION

Tenders shall be signed by a person duly authorised/empowered to do so. An attested copy of the Power of Attorney, in case the tender is signed by an individual other than the sole proprietor shall be submitted along with the tenders

1.8. EARNEST MONEY DEPOSIT

1.8.1 Every tender must be accompanied by the prescribed amount of Earnest Money Deposit (EMD) in the manner described herein.

The EMD may be accepted only in the following forms:

- (i) Electronic Fund Transfer credited in BHEL account (before tender opening)*
- (ii) Banker's cheque/ Pay order/ Demand draft, in favor of BHEL (along with offer) In case total EMD amount is more than Rs 20 Lakh, the amount in excess of Rs 20 lakh maybe accepted in the form of Bank Guarantee from scheduled bank. The Bank Guarantee in such cases shall be valid for at-least six months.*
- (iii) Through SBI collect (before tender opening)*
- (iv) No other form of EMD remittance shall be acceptable to BHEL*

1.8.2 EMD by the bidder will be forfeited as per Tender Documents if

- i) After opening the tender and within the offer validity period, the tenderer revokes his/her tender or makes any modification in his tender which is not acceptable to BHEL.*
- ii) The Contractor fails to deposit the required Security deposit or commence the work within the period as per LOI/ Contract.*
- iii) EMD by the tenderer shall be withheld in case any action on the tenderer is envisaged in derailing the tender process by unlawful means*

1.8.3 EMD shall not carry any interest.

1.8.4 In the case of unsuccessful bidders, the Earnest Money will be refunded to them within a reasonable time after acceptance of award by successful tenderer.

1.8.5 EMD of successful tenderer will be converted as part of Security Deposit

1.9. SECURITY DEPOSIT

The total amount of Security Deposit will be 5% of the contract value (including all applicable taxes) EMD of the successful tenderer shall be converted and adjusted towards the required amount of Security Deposit.

1.9.1 Modes of Security deposit:

The balance amount to make up the required Security Deposit of 5% of the contract value may be accepted in the following forms:

- i) Cash (as permissible under the extant Income Tax Act)*
- ii) Local cheques of Scheduled Banks (subject to realization)/ Pay Order/ Demand Draft/ Electronic Fund Transfer in favour of BHEL*
- iii) Bank Guarantee from Scheduled Banks/ Public Financial Institutions as defined in the Companies Act. The Bank Guarantee format should have the approval of BHEL*
- iv) Fixed Deposit Receipt issued by Scheduled Banks/ Public Financial Institutions as defined in the Companies Act (FDR should be in the name of the Contractor, a/c BHEL)*
- v) Securities available from Indian Post offices such as National Savings Certificates, Kisan Vikas Patras etc. (held in the name of Contractor furnishing the security and duly endorsed/ hypothecated/ pledged, as applicable, in favour of BHEL) (Note: BHEL will not be liable or responsible in any manner for the collection of interest or renewal of the documents or in any other matter connected therewith)*
- vi) 50% of the required Security Deposit, including the EMD, should be paid before start of the work. Balance of the Security Deposit can be collected by deducting 10% of the gross amount progressively from each of the running bills of the Contractor till the total amount of the required Security Deposit is collected. If the value of work done at any time exceeds the contract value, the amount of Security Deposit shall be correspondingly enhanced and the additional Security Deposit shall be immediately deposited by the Contractor or recovered from payment/s due to the Contractor. Security Deposit shall be released to the Contractor upon fulfilment of contractual obligations as per terms of the contract.*

1.9.2 The Security Deposit shall not carry any interest.

1.9.3 The validity of Bank Guarantees towards Security Deposit shall be initially up to the completion period as stipulated in the Letter of Intent/Award (plus maintenance period if applicable), and 03 months claim period. The same shall be kept valid by proper renewal till the acceptance of Final Bills of the Contractor, by BHEL

1.9.4 BHEL reserves the right of forfeiture of Security Deposit in addition to other claims and penalties in the event of the Contractor's failure to fulfill any of the contractual obligations or in the event of termination of contract as per terms and conditions of contract. BHEL reserves the right to set off the Security Deposit against any claims of other contracts with BHEL.

1.10. REFUND OF SECURITY DEPOSIT

50% of the security deposit may be refunded on completion of the work after payment of the final bill and the balance 50% of the security deposit is refunded only after the expiry of the maintenance period from date of completion of work as stipulated in the contract concerned.

1.10.1 DEFECTS LIABILITY PERIOD:

The contractor shall be responsible to make good and remedy at his own expenses within such period as may be stipulated by the Engineer-in-charge, any defect which may develop or may be noticed before the expiry of the maintenance period of six months or as stipulated in NIT hereto from the certified date of completion and intimation of which has been sent to the contractor within seven days of the expiry of the said period by a letter sent by hand delivery or by registered post or Email. If contractor fails to attend to the above, defect will be rectified at contractor's risk & cost and same will be deducted from the security deposit/payable amounts available with BHEL.

1.11. BANK GUARANTEES

Where ever Bank Guarantees are to be furnished/submitted by the contractor, the following shall be complied with

i) Bank Guarantees shall be from Scheduled Banks / Public Financial Institutions as defined in the Companies Act.

ii) The Bank Guarantees shall be as per prescribed BHEL formats.

iii) It is the responsibility of the bidder to get the Bank Guarantees revalidated/extended for the required period (subject to a minimum period of six months), as per the advice of BHEL. BHEL shall not be liable for issue of any reminders regarding expiry of the Bank Guarantees.

iv) In case extension/further extensions of any Bank Guarantees are not required, the bidders shall ensure that the same is explicitly endorsed by BHEL

v) In case the Bank Guarantees are not extended before the expiry date, BHEL reserves the right to invoke the same by informing the concerned Bank in writing, without any advance notice/communication to the concerned bidder.

vi) Bidders to note that any corrections to Bank Guarantees shall be done by the issuing Bank, only through an amendment in an appropriate non judicial stamp paper.

vii) The Original Bank Guarantee shall be sent directly by the Bank to BHEL under Registered Post (Acknowledgement Due).

1.12. VALIDITY OF OFFER

The rates in the Tender shall be kept open for acceptance for a minimum period of Ninety (90) DAYS from latest due date of offer submission (including extension, if any). In case BHEL calls for negotiations, such negotiations shall not amount to cancellation or withdrawal of the original offer which shall be binding on the tenderers.

1.13 EXECUTION OF CONTRACT AGREEMENT

The successful tenderer's responsibility under this contract commences from the date of issue of the Letter of Intent by BHEL. The Tenderer shall submit an unqualified acceptance to the Letter of Intent/Award within the period stipulated therein.

The successful tenderer shall be required to execute an agreement in the prescribed form, with BHEL, within fifteen days (15 days) after the acceptance of the Letter of Intent/Award, and in any case before releasing the first running bill. The contract agreement shall be signed by a person duly authorized/empowered by the tenderer. The expenses for preparation of agreement document shall be borne by Tenderer.

1.14. REJECTION OF TENDER AND OTHER CONDITIONS

1.14.1 The acceptance of tender will rest with BHEL which does not bind itself to accept the lowest tender or any tender and reserves to itself full rights for the following without assigning any reasons whatsoever:-

- a. To reject any or all of the tenders.*
- b. To split up the work amongst two or more tenderers as per NIT*
- c. To award the work in part if specified in NIT*
- d. In case of either of the contingencies stated in (b) and (c) above, the time for completion as stipulated in the tender shall be applicable.*

1.14.2 Conditional tenders, unsolicited tenders, tenders which are incomplete or not in the form specified or defective or have been materially altered or not in accordance with the tender conditions, specifications etc., are liable to be rejected.

1.14.3 Tenders are liable to be rejected in case of unsatisfactory performance of the tenderer with BHEL, or tenderer under suspension (hold/banning /delisted) by any unit / region / division of BHEL or tenderers who do not comply with the latest guidelines of Ministry/Commissions of Govt of India. BHEL reserves the right to reject a bidder in case it is observed that they are overloaded and may not be in a position to execute this job. The decision of BHEL will be final in this regard.

1.14.4 If a tenderer who is a proprietor expires after the submission of his tender or after the acceptance of his tender, BHEL may at their discretion, cancel such tender. If a partner of a firm expires after the submission of tender or after the acceptance of the tender, BHEL may then cancel such tender at their discretion, unless the firm retains its character.

1.14.5 BHEL will not be bound by any Power of Attorney granted by changes in the composition of the firm made subsequent to the execution of the contract. They may, however, recognize such power of Attorney and changes after obtaining proper legal advice, the cost of which will be chargeable to the contractor concerned.

1.14.6 If the tenderer deliberately gives wrong information in his tender, BHEL reserves the right to reject such tender at any stage or to cancel the contract if awarded and forfeit the Earnest Money/Security Deposit/any other money due.

1.14.7 Canvassing in any form in connection with the tenders submitted by the Tenderer shall make his offer liable to rejection.

1.14.8 In case the Proprietor, Partner or Director of the Company/Firm submitting the Tender, has any relative or relation employed in BHEL, the authority inviting the Tender shall be informed, along with the Offer. Failing to do so, BHEL may, at its sole discretion, reject the tender or cancel the contract and forfeit the Earnest Money/Security Deposit.

1.14.9 The successful tenderer should not sub-contract part or complete work detailed in the tender specification undertaken by him without written permission of BHEL's Construction Manager/Site Incharge. The tenderer is solely responsible to BHEL for the work awarded to him.

1.14.10 The Tender submitted by a techno commercially qualified tenderer shall become the property of BHEL who shall be under no obligation to return the same to the bidder. However unopened price bids and late tenders shall be returned to the bidders after finalization of contract.

1.14.11 Unsolicited discount received after the due date and time of Bid Submission shall not be considered for evaluation. However, if the party who has submitted the unsolicited discount/rebate becomes the L-I party, then the awarded price i.e contract value shall be worked out after considering the discount so offered.

1.14.12 BHEL shall not be liable for any expenses incurred by the bidder in the preparation of the tender irrespective of whether the tender is accepted or not.

1.15 BHEL Fraud Prevention Policy :

The bidder along with its associate/ collaborators/sub-contractors/ Sub-Vendors/ Consultants/service providers shall strictly adhere to BHEL Fraud Prevention Policy displayed on BHEL website <http://www.bhel.com> and shall immediately bring to the notice of BHEL Management about any fraud or suspected fraud as soon as it comes to their notice. Fraud prevention policy and list of Nodal officers shall be hosted on BHEL website, vendor portals of Units/Regions Internet.

CHAPTER-2

2.1 DEFINITION: The following terms shall have the meaning hereby assigned to them except where the context otherwise requires

i) BHEL shall mean Bharat Heavy Electricals Limited, a company registered under Companies Act 1956, with its Registered Office at BHEL HOUSE, SIRI FORT, NEW DELHI – 110 049, or its Authorised Officers or its Site Engineers or other employees authorised to deal with any matters with which these persons are concerned on its behalf.

ii) “EXECUTIVE DIRECTOR” or ‘GROUP GENERAL MANAGER’ or “GENERAL MANAGER (Incharge)” or “GENERAL MANAGER” shall mean the Officer in Electronics Division, Mysore road, Bengaluru-560026

iii) “COMPETENT AUTHORITY” shall mean Executive Director or Group General Manager or General Manager (In-charge) or General Manager or BHEL Officers who are empowered to act on behalf of the Executive Director or General Manager (In-charge) or General Manager of BHEL.

iv) “ENGINEER” or “ENGINEER IN CHARGE” shall mean an Officer of BHEL as may be duly appointed and authorized by BHEL to act as “Engineer” on his behalf for the purpose of the Contract, to perform the duty set forth in this General Conditions of Contract and other Contract documents. The term also includes ‘CONSTRUCTION MANAGER’ or ‘SITE INCHARGE’ as well as Officers

v) “SITE” shall mean the places or place at which the plants/equipment are to be erected and services are to be performed as per the specification of this Tender.

vi) “CLIENT OF BHEL” or “CUSTOMER” shall mean the project authorities with whom BHEL has entered into a contract for supply of equipment or provision of services.

vii) “CONTRACTOR” shall mean the successful Bidder/Tenderer who is awarded the Contract and shall include the Contractor’s successors, heirs, executors, administrators and permitted assigns.

viii) “CONTRACT” or “CONTRACT DOCUMENT” shall mean and include the Work Order, Contract Agreement, the accepted appendices of Rates, Schedules, Quantities if any, General Conditions of Contract, Special Conditions of Contract, Instructions to the Tenderers, Drawings, Technical Specifications, the Special Specifications if any, the Tender documents, subsequent amendments mutually agreed upon and the Letter of Intent/Acceptance issued by BHEL. Any conditions or terms stipulated by the contractor in the tender documents or subsequent letters shall not form part of the contract unless, specifically accepted in writing by BHEL in the Letter of Intent/Award and incorporated in the agreement.

ix) “GENERAL CONDITIONS OF CONTRACT” shall mean the ‘Instructions to Tenderers’ and ‘General Conditions of Contract’ pertaining to the work for which above tenders have been called for.

x) “TENDER SPECIFICATION” or “TENDER” or “TENDER DOCUMENTS” shall mean General Conditions, Common Conditions, Special Conditions, Price Bid, Rate Schedule, Technical Specifications, Appendices, Annexures, Corrigendum’s, Amendments, Forms, procedures, Site information, etc and drawings/documents pertaining to the work for which the tenderers are required to submit their offers. Individual specification number will be assigned to each Tender Specification.

xi) “LETTER OF INTENT” shall mean the intimation by a Post/Fax/email to the tenderer that the tender has been accepted in accordance with provisions contained in the letter. The responsibility of the contractor commences from the date of issue of this letter and all terms and conditions of the contract are applicable from this date.

xii) “COMPLETION TIME” shall mean the period by ‘date/month’ specified in the ‘Letter of Intent/Award’ or date mutually agreed upon for handing over of the intended scope of work, the erected equipment/plant which are found acceptable by the Engineer, being of required standard and conforming to the specifications of the Contract.

xiii) “PLANT” shall mean and connote the entire assembly of the plant and equipment’s covered by the contract.

xiv) “EQUIPMENT” shall mean equipment, machineries, materials, structural, electrical and other components of the plant covered by the contract.

xv) “TESTS” shall mean and include such test or tests to be carried out on the part of the contractor as are prescribed in the contract or considered necessary by BHEL, in order to ascertain the quality, workmanship, performance and efficiency of the contractor or part thereof.

xvi) “APPROVED”, “DIRECTED” or “INSTRUCTED” shall mean approved, directed or instructed by BHEL.

xvii) *“WORK or CONTRACT WORK” shall mean and include supply of all categories of labour, specified consumables, tools and tackles and Plants required for complete and satisfactory site transportation, handling, stacking, storing, erecting, testing and commissioning of the equipment’s to the entire satisfaction of BHEL.*

xviii) *“SINGULAR AND PLURALS ETC” words carrying singular number shall also include plural and vice versa, where the context so requires. Words imparting the masculine Gender shall be taken to include the feminine Gender and words imparting persons shall include any Company or Associations or Body of Individuals, whether incorporated or not.*

xix) *“HEADING” – The heading in these General Conditions are solely for the purpose of facilitating reference and shall not be deemed to be part thereof or be taken as instructions thereof or of the contract.*

xx) *“MONTH” shall mean calendar month unless otherwise specified in the Tender.*

xxi) *Day’ or ‘Days’ unless herein otherwise expressly defined shall mean calendar day or days of twenty four (24) hours each. A week shall mean continuous period of seven (7) days.*

xxii) *“COMMISSIONING” shall mean the synchronization testing and achieving functional operation of the Equipment with associated system after all initial adjustments, trials, cleaning, re-assembly required at site if any, have been completed and Equipment with associated system is ready for taking into service.*

xxiii) *“WRITING” shall include any manuscript type written or hand written or printed statement or electronically transmitted messages, under the signature or seal or transmittal of BHEL.*

xxiv) *“TEMPORARY WORK” shall mean all temporary works for every kind required in or for the execution, completion, maintenance of the work.*

xxv) *‘CONTRACT PRICE’ or ‘CONTRACT VALUE’ shall mean the sum including applicable taxes mentioned in the LOI/LOA/Contract Agreement subject to such additions thereto or deductions there from as may be made under provisions hereinafter contained*

xxvi) *“COMMENCEMENT DATE” or “START DATE” shall mean the commencement/start of work at Site as per terms defined in the Tender*

xxvii) *“SHORT CLOSING” or “FORE CLOSING” of Contract shall mean the premature closing of Contract, for reasons not attributable to the contractor and mutually agreed between BHEL and the contractor*

xxviii) *“TERMINATION” of Contract shall mean the pre mature closing of contract due to reasons as mentioned in the contract*

2.2 LAW GOVERNING THE CONTRACT AND COURT JURISDICTION

The contract shall be governed by the Law for the time being in force in the Republic of India. The Civil Court having original Civil Jurisdiction at Bengaluru, shall alone have exclusive jurisdiction in regard to all claims in respect of the Contract. No other Civil Court shall have jurisdiction in case of any dispute, under this contract

2.3 ISSUE OF NOTICE

2.3.1 Service of notice on contractor: Any notice to be given to the Contractor under the terms of the contract shall be served by sending the same by Registered Post / Speed Post / FAX / Email to or leaving the same at the Contractor's last known address of the principal place of business (or in the event of the contractor being a company, to or at its Registered Office). In case of change of address, the notice shall be served at changed address as notified in writing by the Contractor to BHEL. Such posting or leaving of the notice shall be deemed to be good service of such notice and the time mentioned to the condition for doing any act after notice shall be reckoned from the date so mentioned in such notice.

2.3.2 Service of notice on BHEL Any notice to be given to BHEL in-charge under the terms of the Contract shall be served by sending the same by post or Email or leaving the same at BHEL address or changed address as notified in writing by BHEL to the Contractor.

2.4 USE OF LAND

No land belonging to BHEL or their Customer under temporary possession of BHEL shall be occupied by the contractor without written permission of BHEL.

2.4.1 STORES AND MATERIALS:

The contractor shall, at his own expense, supply all stores and materials required for the contract, other than those which may be provided by BHEL at the rates detailed therein subject to their availability at the place of issue indicated therein. All stores and materials to be supplied by the Contractor shall be of the best kind as described in the Specifications and the Contractor shall, if required by the Engineer –in- charge furnish him with proof to his satisfaction that the store and materials so comply with the specifications.

The contractor shall, at his own expense and without delay, supply samples of stores and materials proposed to be used in the execution of the work for the approval of the Engineer-in charge, who may reject all stores and materials not corresponding either in quality or character to the approved samples.

In the case of stores provided by BHEL, the Contractor shall bear the cost of loading, transporting to site, unloading, storing under cover as required, assembling & jointing the several parts together as necessary and incorporating & fixing these stores & materials in the work, including all preparatory work of whatever description that may be required, and closing, preparing, loading and returning empty cases or containers to the place of issue without any extra charges.

Contractor is responsible for safe & secure storage of above material.

2.4.2 PATENT RIGHTS:

The contractor shall fully indemnify BHEL, or the agent, servant, or employee of BHEL, against any action, claim or proceeding relating to infringement or the use of any patent or design or any alleged patent or design rights, and shall pay any royalties which may be payable in respect of any article/ or part thereof included in the contract.

In the event of any claims being made or action brought against BHEL, or any agent, or servant or employee of BHEL., in respect of any of the matters aforesaid, the contractor shall not apply when such increment has taken place in complying with the specific directions issued by the BHEL but the contractor shall pay any royalties payable in respect of any such use.

2.4.3 WATER :

The contractor shall allow in his tender and provide at his cost all water required for the work or his employees on the work, together with all pipes and fittings or other means that may be necessary or required to ensure a proper and ample supply of water for all purpose connected with the work.

In the event of a provision existing in the Tender documents for supply of water on payment by BHEL, water will be supplied from the BHEL supply System, or other sources at any points fixed by the Site Engineer/ Engineer-in-charge on the site of work. The contractor shall make necessary arrangement for lifting, pumping, carrying or conveying the water as required at his own cost. The levy of water charges to be borne by the Contractor in such case shall be specifically mentioned in the Tender documents.

2.4.4 TEMPORARY WORKSHOPS, STORES ETC :

The Contractor shall, during the progress of the work provide, erect and maintain at his own expense all necessary temporary workshops, store, offices, toilets etc., required for the proper and efficient execution of the work. The planning, siting and erection of these building shall have the approval of the Engineer-in-charge and the Contractor shall at all times keep them in a clean and sanitized condition to the entire satisfaction of the Engineer-in-charge.

On completion of the work all such temporary buildings shall be cleared and the site restored to its original state in a clean and tidy condition to the entire satisfaction of the Engineer-in-charge.

2.5 COMMENCEMENT OF WORK

2.5.1 Time is essence of contract and is specified in the tender document or in each individual work order.

2.5.2 The contractor shall commence the work within seven(07) days from LOI/work order or as intimated by BHEL and shall proceed with the same with due expedition without delay.

2.5.3 If the contractor fails to start the work within stipulated time as per LOI or as intimated by BHEL, then BHEL at its sole discretion will have the right to cancel the contract. The Earnest Money and/or Security Deposit with BHEL will stand forfeited without any further reference to him without prejudice to any and all of BHEL's other rights and remedies in this regard.

2.5.4 All the work shall be carried out under the direction and to the satisfaction of BHEL.

2.6 MEASUREMENT OF WORK AND MODE OF PAYMENT:

2.6.1 All payments due to the contractors shall be made by electronic mode only, unless otherwise found operationally difficult.

2.6.2 For progress running bill payments: - The Contractor shall present detailed measurement sheets in triplicate, duly indicating all relevant details based on technical documents and connected drawings for work done during the month/period under various categories in line with terms of payment as per contract. The basis of arriving at the quantities, weights shall be relevant documents and drawings released by BHEL. These measurement sheets shall be prepared jointly with BHEL Engineers and signed by both the parties.

2.6.3 These measurement sheets will be checked by BHEL Engineer and quantities and percentage eligible for payment under various groups shall be decided by BHEL Engineer. The abstract of quantities and percentage so arrived at based on the terms of payment shall be entered in Measurement Book and signed by both the parties.

2.6.4 Based on the above quantities, contractor shall prepare the bills in prescribed format and work out the financial value. These will be entered in Measurement Book and signed by both the parties. Payment shall be made by BHEL after effecting the recoveries due from the contractor.

2.6.5 All recoveries due from the contractor for the month/period shall be effected in full from the corresponding running bills unless specific approval from the competent authorities is obtained to the contrary.

2.6.6 Measurement shall be restricted to that portion of work for which it is required to ascertain the financial liability of BHEL under this contract.

2.6.7 The measurement shall be taken jointly by persons duly authorized on the part of BHEL and by the Contractor.

2.6.8 The Contractor shall bear the expenditure involved if any, in making the measurements and testing of materials to be used/used in the work. The contractor shall, without extra charges, provide all the assistance with appliances and other things necessary for measurement.

2.6.9 *If at any time due to any reason whatsoever, it becomes necessary to re-measure the work done in full or in part, the expenses towards such re measurements shall be borne by the contractor unless such re measurements are warranted solely for reasons not attributable to contractor.*

2.6.10 *Passing of bills covered by such measurements does not amount to acceptance of the completion of the work measured. Any left out work has to be completed, if pointed out at a later date by BHEL.*

2.6.11 *Final measurement bill shall be prepared in the final bill format prescribed for the purpose based on the certificate issued by BHEL Engineer that entire works as stipulated in tender specification has been completed in all respects to the entire satisfaction of BHEL. Contractor shall give unqualified "No Claim" Certificate. All the tools and tackles loaned to him should be returned in satisfactory condition to BHEL. The abstract of final quantities and financial values shall also be entered in the Measurement Books and signed by both parties to the contract. The Final Bill shall be prepared and paid within a reasonable time after completion of work.*

2.7 RIGHTS OF BHEL

BHEL reserves the following rights in respect of this contract during the original contract period or its extensions if any, as per the provisions of the contract, without entitling the contractor for any compensation.

2.7.1 *To withdraw any portion of work and/or to restrict/alter quantum of work as indicated in the contract during the progress of work and get it done through other agencies to suit BHEL's commitment to its customer or in case BHEL decides to advance the date of completion due to other emergent reasons/ BHEL's obligation to its customer.*

2.7.2 *To terminate the contract or get any part of the work done through other agency or deploy BHEL's own/hired/otherwise arranged resources , at the risk and cost of the contractor after due notice of a period of two weeks by BHEL, in the event of:-*

- i) Contractor's continued poor progress*
- ii) Withdrawal from or abandonment of the work before completion of the work*
- iii) Contractor's inability to progress the work for completion as stipulated in the contract*
- iv) Poor quality of work*
- v) Corrupt act of Contractor*
- vi) Insolvency of the Contractor*

vii) *Persistent disregard to the instructions of BHEL*

viii) *Assignment, transfer, sub-letting of contract without BHEL's written permission*

ix) *Non fulfillment of any contractual obligations / non-compliance of statutory requirements*

x) *In the opinion of BHEL, the contractor is overloaded and is not in a position to execute the job as per required schedule*

2.7.3 To meet the expenses including BHEL overheads of 35% & Liquidated damage/penalties arising out of "Risk & Cost" as explained above under Sl.No. 2.7.2. BHEL shall recover the amount from any money due from Contractor, from any money due to the Contractor including Security Deposit or by forfeiting any T&P or material of the contractor under this contract or any other contract of BHEL or by any other means or any combination thereof

2.7.4 To terminate the contract or to restrict the quantum of work and pay for the portion of work executed in case BHEL's contract with their customer are terminated for any reason, as per mutual agreement.

2.7.5 To effect recovery from any amounts due to the contractor under this or any other contract or in any other form, the moneys BHEL is statutorily forced to pay to anybody, due to contractor's failure to fulfill any of his obligations. BHEL shall levy overheads of 35% on all such payments.

2.7.6 While every endeavor will be made by BHEL to this end, they cannot guarantee uninterrupted work due to conditions beyond their control. The Contractor will not be normally entitled for any compensation/extra payment on this account unless otherwise specified elsewhere in the contract.

2.7.7 In case the execution of works comes to a complete halt or reaches a stage wherein worthwhile works cannot be executed and there is no possibility of commencement of work for a period of not less than two months, due to reasons not attributable to the contractor and other than Force Majeure conditions, BHEL may consider permitting the contractor to demobilize forthwith and re mobilize at an agreed future date. Cost of such demobilization/remobilization shall be mutually agreed. ORC (Over run Charges) in such cases shall not be applicable for the period between the period of demobilization and re mobilisation. The duration of contract/time extension shall accordingly get modified suitably. In case of any conflict, BHEL decision in this regard shall be final and binding on the contractor.

2.7.8 In the unforeseen event of inordinate delay in receipt of materials, drawings, fronts, etc, due to which inordinate discontinuity of work is anticipated, BHEL at its discretion may consider contractor's request to short close the contract, provided that the balance works are minor vis a vis the scope of work envisaged as per the contract. At the point of requesting for

short closure, contractor shall establish that he has completed all works possible of completion and he is not able to proceed with the balance works due to constraints beyond his control. In such a case, the estimated value of the unexecuted portion of work as mutually agreed, shall however be reduced from the final contract value-

2.7.9 LIQUIDATED DAMAGES/PENALTY

COMPENSATION FOR DELAY:

If the contractor fails to maintain the required progress in terms of condition 2.10 or to complete the work and clear the site on or before the contracted or extended the period of completion, he shall, without prejudice to any other right or remedy of the BHEL on account of such breach, pay as agreed compensation an amount calculated as stipulated below

For unfinished anticipated value of work where finished portion is fit for use

Rate of compensation as follows:

- *Completion period (as originally stipulated) not exceeding 6 months.@ 1 percent per week*
- *Completion period (as originally stipulated) Exceeding 6 months and not exceeding 2 years...@ 0.5 percent per week*
- *Completion period (as originally stipulated) exceeding 2 years..... @ 0.25 percent per week*

Provided always that the total amount of compensation for delay to be paid under condition shall not exceed the under noted percentage of the anticipated contract value

- *Completion period (as originally stipulated) not exceeding 6 months.@ 10 percent of anticipated value of work*
- *Completion period (as originally stipulated) Exceeding 6 months and not exceeding 2 years...@ 7.5 percent of anticipated value of work*
- *Completion period (as originally stipulated) Exceeding 2 years.....@ 5 percent of anticipated value of work*

The amount of compensation may be adjusted or set off against any sum payable to the Contractor under this or any other contract with the BHEL.

2.7.10 POST TECHNICAL AUDIT OF WORK AND BILLS: *BHEL reserve the right to carry out a post-payment audit and technical examination of the work and final bill including all supporting vouchers, abstract etc., and to enforce recovery of any sums becoming due as a result thereof in the manner provided in the proceeding sub-paragraph's provided however that no such recovery shall be enforced after three years of passing the final bill*

2.8 RESPONSIBILITIES OF THE CONTRACTOR IN RESPECT OF LOCAL LAWS, EMPLOYMENT OF WORKERS ETC.

The following are the responsibilities of the contractor in respect of observance of local laws, employment of personnel, payment of taxes etc. The subcontractor shall fully indemnify BHEL against any claims of whatsoever nature arising due to the failure of the contractor in discharging any of his responsibilities hereunder:

2.8.1 The contractor at all times during the continuance of this contract shall, in all his dealings with local labour for the time being employed on or in connection with the work, have due regard to all local festivals and religious and other customs.

2.8.2 The contractor shall comply with all applicable State and Central Laws, Statutory Rules, Maternity act, Regulations etc. such as contract labour(R&A) Act 1970, Minimum wage Act 1948, Payment of wages Act 1936,ESI Act 1948, EPF Act 1952, Employees' compensation Act 1923, Provision of Companies Act 1948 & rules thereof, The interstate Migrant Workmen 1979, The Karnataka Factories Rules 1969, Payment of Bonus Act 1965, Payment of Gratuity Act 1972. Child labour Prohibition act 1986, Karnataka Minimum Wage Act , Prevention of sexual harassment at work place Act 2013, Guidelines/notification related to Safai Karamchari Act , Equal Remuneration Act 1976, The company's instructions as issued from time to time in regard to working hours, wages, leaves, holidays etc. for labour as may be enacted by the Government during the tenure of the Contract and having force or jurisdiction at Site. The Contractor shall also give to the local Governing Body, Police and other relevant Authorities all such notices as may be required by the Law.

The contractor shall produce the following registers and forms:

- Form XIII- Register of work men employed by contractor(Rule 75)*
- Form XIV- Employment Card issued by contractor(Rule 76)*
- Form XVI- Muster Roll (Rule 78(1) (a)(i))*
- Form XVII- Register of Wages (Rule 78(1) (a)(i))*
- Form XVIII- Register of wages cum Muster Roll(in case of weekly payment)*
- Form XIX- Wage slip (Rule 78(b))*
- Form XX- Register of deduction for damages Or Loss Rule 78(1) (a)(ii)*
- Form XXI- Register of files Rule 78(1) (a)(ii)*
- Form XXII- Register of Advance Rule 78(1) (a)(ii)*
- Form XXIII- Register of Overtime Rule 78(1) (a)(iii)*
- Form XXIV- Return to be sent by the contractor to the Licensing officer (Rule 82(1))*

2.8.3 The contractor shall obtain independent License under the Contract Labour (Regulations and Abolition Act)as required from the concerned Authorities based on the certificate (Form-V) issued by the Principal Employer/Customer

2.8.4 The contractor shall pay all taxes, fees, license charges, deposits, duties, tolls, royalties, commission or other charges which may be levied on account of his operations in executing the contract.

2.8.5 While BHEL would pay the inspection fees and Registration fees of Boiler & explosive/Electrical Inspectorate, all other arrangements for site visits periodically by the Inspectorate to site, Inspection certificate etc. will have to be made by contractor. However, BHEL will not make any payment to the Inspectorate in connection with contractor's Welders/Electricians qualification tests etc.

2.8.6 Contractor shall be responsible for provision of Health and Sanitary arrangements (more particularly described in Contract Labour Regulation & Abolition Act), Safety precautions etc. as may be required for safe and satisfactory execution of contract.

2.8.7 The contractor shall be responsible for proper accommodation including adequate medical facilities for personnel employed by him.

2.8.8 The contractor shall be responsible for the proper behavior and observance of all regulations by the staff employed by him.

2.8.9 The contractor shall ensure that no damage is caused to any person/property of other parties working at site. If any such damage is caused, it is responsibility of the contractor to make good the losses or compensate for the same.

2.8.10 All the properties/equipment/components of BHEL/their Client loaned with or without deposit to the contractor in connection with the contract shall remain properties of BHEL/their Client.

2.8.11 The contractor shall use such properties for the purpose of execution of this contract. All such properties/equipment/components shall be deemed to be in good condition when received by the contractor unless he notifies within 48 hours to the contrary. The contractor shall return them in good condition as and when required by BHEL/their Client. In case of non-return, loss, damage, repairs etc, the cost thereof as may be fixed by BHEL Engineer will be recovered from the contractor

2.8.12 Any delay in completion of works/or non-achievement of periodical targets due to the reasons attributable to the contractor, the same may have to be compensated by the contractor either by increasing manpower and resources or by working extra hours and/or by working more than one shift. All these are to be carried out by the contractor at no extra cost.

2.8.13 The contractor shall arrange, coordinate his work in such a manner as to cause no hindrance to other agencies working in the same premises.

2.8.14 All safety rules and codes applied by the Client/BHEL at site shall be observed by the contractor without exception. The contractor shall be responsible for the safety of the equipment/material and works to be performed by him and shall maintain all light, fencing guards, slings etc. or other protection necessary for the purpose. Contractor shall also take such additional precautions as may be indicated from time to time by the Engineer with a view to prevent pilferage, accidents, fire hazards. Due precautions shall be taken against fire hazards and atmospheric conditions. Suitable number of Clerical staff, watch and ward, store keepers to take care of equipment/materials and construction tools and tackles shall be posted at site by the contractor till the completion of work under this contract. The contractor shall arrange for such safety devices as are necessary for such type of work and carry out the requisite site tests of handling equipment, lifting tools, tackles etc. as per prescribed standards and practices. Contractor has to ensure the implementation of Health, Safety and Environment (HSE) requirements as per directions given by BHEL/Customer. The contractor has to assist in HSE audit by BHEL/Customer and submit compliance Report. The contractor has to generate and submit record/reports as per HSE plan/activities as per instruction of BHEL/Customer. All tools, plant and equipment brought to the site shall become the property of BHEL and shall not be removed from the site without the prior written approval from BHEL. When the work is finally completed or the Contractor is determined for reasons other than the defaults of the contract, he shall forthwith remove from the site all tools, plants, equipment etc., (other than those as may have been provided by BHEL) and upon such removal, the same shall revert in, and become the property of the contractor.

2.8.15 The contractor will be directly responsible for payment of wages to his workmen on specified date of respective month declared as per applicable Labour Act. A pay roll sheet giving all the payments given to the workers and duly signed by the contractor's representative should be furnished to BHEL site for record purpose.

2.8.16 In case of any class of work for which there is no such specification as laid down in the contract, such work shall be carried out in accordance with the instructions and requirements of the Engineer.

2.8.17 Also, no idle charges will be admissible in the event of any stoppage caused in the work resulting in contractor's labour and Tools & Plants being rendered idle due to any reason at any time.

2.8.18 The contractor shall take all reasonable care to protect the materials and work till such time the plant/equipment has been taken over by BHEL or their Client whichever is earlier.

2.8.19 The contractor shall not stop the work or abandon the site for whatsoever reason of dispute, excepting force majeure conditions. All such problems/disputes shall be separately discussed and settled without affecting the progress of work. Such stoppage or abandonment shall be treated as breach of contract and dealt with accordingly

2.8.20 The contractor shall keep the area of work clean and shall remove the debris etc. while executing day-to-day work. Upon completion of work, the contractor shall remove from the vicinity of work, all scrap, packing materials, rubbish, unused and other materials and deposit them in places specified by the Engineer. The contractor will also demolish all the hutments, sheds, offices, etc. constructed and used by him and shall clean the debris. In the event of his failure to do so, the same will be arranged to be done by the Engineer and the expenses recovered from the contractor. If the work is executed in Factory premises, no hutment will be allowed.

2.8.21 The contractor shall execute the work in the most substantial and workman like manner in the stipulated time. Accuracy of work and timely execution shall be the essence of this contract. The contractor shall be responsible to ensure that the quality, assembly and workmanship conform to the dimensions and clearance given in the drawings and/ or as per the instructions of the Engineer.

2.8.22 The Contractor to note that some of BHEL's T&Ps/MMDs may not be insured. The Contractor will take necessary precautions and due care to protect the same while in his custody from any damage/ loss till the same is handed over back to BHEL. In case the damage / loss is due to carelessness/ negligence on the part of the contractor, the Contractor is liable to get them repair/ replaced immediately and in case of his failure to do so within a reasonable time, BHEL will reserve the right to recover the loss from the contractor.

2.8.23 The contractor shall provide all watchmen necessary, for the protection of the site, the work, the materials, the tools , plant, equipment and anything else lying on the site during the progress of the work. He shall solely be responsible for and shall take all reasonable and proper steps for protecting, securing , lighting and watching all places on or about the work and the site which may be dangerous to any person whom so ever.

2.8.24 **SITE DRAINAGE:** All water that may accumulate on the site during the process of the work, or in trenches and excavations shall be removed to the entire satisfaction of the Engineer-in-charge and at Contractors expense.

2.8.25 **INSPECTION OF THE WORK:** BHEL Officers concerned with the Contract shall have power at any time to inspect and examine any part of the work and the contractor shall give such facilities as may be required to given for such inspection and examination.

2.8.26 In case the contractor is required to undertake any work outside the scope of this contract, the rates payable shall be those mutually agreed upon if the item rates are not mentioned in existing contract

- i. For any item of wok required to be carried out after the contract has been awarded and which is not covered by Contractors Schedule but is covered by C.P.W.D. schedule of rates the rate payable for such a fresh item will be derived from updated C.P.W.D. schedule of rates by the method of proportion as follows:

- ii. *Rate as per estimated updated C.P.W.D DSR and loading tender excess (plus or minus) on pro-rata basis for nearest analogous items. For other items rate as per estimated C.P.W.D DSR and loading tender excess(plus or minus)*
- iii. *If rates are not available in C.P.W.D. DSR, deviated item rates will be derived from market rate with 15% profit and overheads.*

2.9 PROGRESS MONITORING, MONTHLY REVIEW AND PERFORMANCE EVALUATION

2.9.1 A detailed plan/programme for completion of the contractual scope of work as per the time schedule given in the contract shall be jointly agreed between BHEL and Contractor, before commencement of work . The above programme shall be supported by month wise deployment of resources viz Manpower, T&P, Consumables, etc. Progress will be reviewed periodically (Daily/Weekly/Monthly) vis a vis this jointly agreed programme. The Contractor shall submit periodical progress reports (Daily/Weekly/Monthly) and other reports/information including manpower, consumables, T&P mobilization etc as desired by BHEL.

2.9.2 Monthly progress review between BHEL and Contractor shall be based on the agreed programme as above, availability of inputs/fronts etc, and constraints if any, as per prescribed formats. Manpower, T&P and consumable reports as per prescribed formats shall be submitted by contractor every month. Release of RA Bills shall be contingent upon certification by BHEL Site Engineer of the availability of the above prescribed formats duly filled in and signed.

2.9.3 The burden of proof that the causes leading to any shortfall is not due to any reasons attributable to the contractor is on the contractor himself. The monthly progress review shall record shortfalls attributable to (i) Contractor, (ii) Force Majeure Conditions, and (iii) BHEL

2.10 TIME OF COMPLETION

2.10.1 Time is essence of the contract. The time schedule shall be as prescribed in the Contract. The time for completion shall be reckoned from the date of commencement of work at Site as certified by BHEL Engineers

2.10.2 The entire work shall be completed by the contractor within the time schedule or within such extended periods of time as may be allowed by BHEL under clause 2.11

2.11 EXTENSION OF TIME FOR COMPLETION

2.11.1 If the completion of work as detailed in the scope of work gets delayed beyond the contract period, the contractor shall request for an extension of the contract and BHEL at its discretion may extend the Contract.

2.11.2 Based on the monthly reviews jointly signed, the works balance at the end of original contract period less the backlog attributable to the contractor shall be quantified, and the number of months of 'Time extension' required for completion of the same shall be jointly worked out. Within this period of 'Time extension', the contractor is bound to complete the portion of backlog attributable to the contractor. Any further 'Time extension' or 'Time extensions' at the end of the previous extension shall be worked out similarly.

2.11.3 However if any 'Time extension' is granted to the contractor to facilitate continuation of work and completion of contract, due to backlog attributable to the contractor alone, then it shall be without prejudice to the rights of BHEL to impose penalty/LD for the delays attributable to the contractor, in addition to any other actions BHEL may wish to take at the risk and cost of contractor.

2.11.4 A joint programme shall be drawn for the balance amount of work to be completed during the period of 'Time Extension', along with matching resources (with weightages) to be deployed by the contractor as per specified format. Review of the programme and record of shortfall shall be done every month of the 'Time extension' period in the same manner as is done for the regular contract period.

2.11.5 During the period of 'Time extension', contractor shall maintain their resources as per mutually agreed program

2.11.6 At the end of total work completion as certified by BHEL Engineer, and upon analysis of the total delay, the portion of time extensions attributable to (i) Contractor, (ii) Force majeure conditions, and (iii) BHEL, shall be worked out and shall be considered to be exhausted in the same order. The total period of time extensions shall be the sum of (i), (ii) and (iii) above and shall be equal to period between the scheduled date of completion and the actual date of completion of contract. LD shall be imposed/levied for the portion of time extensions attributable to contractor and recoverable from the dues payable to the contractor.

2.12 OVERRUN COMPENSATION (THIS CLAUSE IS NOT APPLICABLE IN BHEL FACTORY & TOWNSHIP PREMISES)

2.12.1 Over Run Compensation (ORC) is payable by way of rate revisions for periods beyond original, contract period subject to the following terms and conditions.

2.12.2 Rates shall be increased by 10% for the first twelve months of one or more extensions beyond original contract period. For the next twelve months of further extensions if any, rates shall be increased as above by 10% over the previous twelve months, and similarly for each subsequent twelve months extension.

2.12.3 Should there be any 'Time extension' for reasons attributable only to the contractor, then the work shall be executed by the contractor at the rates applicable for the period the work was planned

2.12.4 Payment of ORC shall be regulated as follows:

i) Contractor is entitled to Over Run Compensation (ORC) only for the portion of backlog attributable to BHEL.

ii) 50% of the compensation is allocated for deployment of resources agreed as per the joint programme drawn vide 2.11.4. Payment shall however be based on the actual deployment of resources for the month as certified by BHEL, as per weightages assigned therein

iii) 50% of the compensation, is allocated for achieving of planned progress agreed as per the joint programme drawn vide 2.11.4. Payment shall be on pro rata basis for actual achieved quantities

iv) Total Over Run Compensation shall be limited to 10% of the executed contract value as certified in Final Bill. For this purpose executed contract value excludes PVC, ORC, Supplementary/Additional Items and Extra Works done on Man-day rate basis

2.12.5 Contractor shall not be entitled for any Over Run Compensation (ORC) for the portion of backlog attributable to the contractor. Such works shall be executed at the rates applicable for the period the work was planned

2.13 QUANTITY VARIATION

2.13.1 The quoted rates shall remain firm irrespective of any variations in the individual quantities.

2.14 EXTRA WORKS

2.14.1 All rectifications/modifications, revamping, and reworks required for any reasons not attributable to the contractor, or needed due to any change in deviation from drawings and design of equipment, operation/maintenance requirements, mismatching, or due to damages in transit, storage and erection/commissioning, and other allied works which are not very specifically indicated in the drawings, but are found essential for satisfactory completion of the work, will be considered as extra works.

2.14.2 Extra works arising on account of the contractor's fault, irrespective of time consumed in rectification of the damage/loss, will have to be carried out by the contractor free of cost. Under such circumstances, any material and consumable required for this purpose will also have to be arranged by the contractor at his cost.

2.14.3 All the extra work should be carried out by a separately identifiable gang, without affecting routine activities. Daily log sheets in the pro-forma prescribed by BHEL should be maintained and shall be signed by the contractor's representative and BHEL engineer. No claim for extra work will be considered/entertained in the absence of the said supporting documents i.e. daily log sheets. Signing of log sheets by BHEL engineer does not necessarily mean the acceptance of such works as extra works.

2.14.4 BHEL retains the right to award or not to award any of the major repair/rework/modification/rectification/fabrication works to the contractor, at their discretion without assigning any reason for the same

2.14.5 After eligibility of extra works is established and finally accepted by BHEL engineer/designer, payment will be released on competent authority's approval at the following rate.

MAN-HOUR RATE FOR ELIGIBLE EXTRA WORKS: Single composite average labour man-hour rate, including overtime if any, supervision, use of tools and tackles and other site expenses and incidentals, consumables for carrying out any major rework/repairs/rectification/modification/fabrication as certified by site as may arise during the course of erection, testing, commissioning or extra works arising out of transit, storage and erection damages, payment, if found due will be as per applicable minimum wage act

2.14.6 The above composite labour man hour rate towards extra works shall remain firm and not subject to any variation during execution of the work. PVC will not be applicable for extra works. Rate revision, Over Run Charges/compensation etc will not be applicable due to extra works.

2.14.7 Extra Works for Civil Packages shall be regulated as follows

i) Rates for Extra Works arising due to (1) non availability of BOQ (Rate Schedule), OR (2) change in Specifications of materials/works (3) rectification/modification/dismantling & re erecting etc due to no fault of Contractor, shall be in the order of the following:

a) Item rates are to be derived from similar nature of items in the BOQ (Rate Schedule) with applicable escalation derived from All India Consumer Price Index for Whole Sale Commodities.

b) As per applicable updated CPWD-DSR (or latest edition) with applicable escalation derived; Notification issued by the office of CPWD for 'Cost Index' in that Region where the project is being executed,

c) Item rates are to be worked out on the basis of prevailing market rates mutually agreed between BHEL and Contractor, plus 15% towards Contractor's overheads and profit.

ii) PVC and ORC will not applicable be for (i) above.

2.15 SUPPLEMENTARY ITEMS

2.15.1 For NON Civil Works

Supplementary items are items/works required for completion of entire work but not specified in the scope of work. Subject to certification of such items/works as supplementary items by BHEL Engineer, rates shall be derived on the basis of any one of the following on mutual agreement:

i) Based on percentage breakup/rates indicated for similar/nearby items

ii) In case (i) above does not exist, then BHEL/site may derive the percentage breakup/rates to suit the type of work

2.15.2 For Civil Works

i) Rates for Supplementary Works/Additional Works arising out due to additions/alterations in the original scope of works as per contract subject to certification of BHEL Engineer shall be worked out as under:

a) Item rates which are available in existing BOQ (Rate Schedule) shall be operated with applicable escalation derived from All India Consumer Price Index for Whole Sale Commodities

b) Items of works which are not available in existing BOQ shall be operated as an 'Extra Works' and rate shall be derived as per clause no 2.14

ii) Execution of Supplementary Works/Additional Works through the Contractor shall be at the sole discretion of BHEL, and shall be considered as part of executed contract value for the purpose of Quantity Variation as per clause 2.13

iii) BHEL Engineer's decision regarding fixing the rate as above is final and binding on the contractor.

iv) PVC and ORC will not be applicable for (i) above.

2.16 STRIKES & LOCKOUT

2.16.1 The contractor will be fully responsible for all disputes and other issues connected with his labour/employee. In the event of the contractor's labour/employee resorting to strike or the Contractor resorting to lockout and if the strike or lockout declared is not settled within a period of 15 days, BHEL shall have the right to get the work executed through any other

agencies and the cost so incurred by BHEL along with Overhead charges of 35% shall be deducted from the Contractor's bills along with overhead of 35%

2.16.2 For all purposes whatsoever, the employees of the contractor shall not be deemed to be in the employment of BHEL

2.17 FORCE MAJEURE

The following shall amount to Force Majeure:-

2.17.1 Acts of God, act of any Government, War, Sabotage, Riots, Strike, Civil commotion, Police action, Revolution, Flood, Fire, Cyclones, Earth quake and Epidemic and other similar causes over which the contractor has no control.

2.17.2 If the contractor suffers delay in the due execution of the contractual obligation due to delays caused by force majeure as defined above, the agreed time of completion of the job covered by this contract or the obligations of the contractor shall be extended by a period of time equal to period of delay, provided that on the occurrence of any such contingency, the contractor immediately reports to BHEL in writing the causes of delay and the contractor shall not be eligible for any compensation.

2.18 ARBITRATION & RECONCILIATION

2.18.1 In case amicable settlement is not reached in the event of any dispute or difference arising out of the execution of the Contract or the respective rights and liabilities of the parties or in relation to interpretation of any provision by the Contractor in any manner touching upon the Contract, such dispute or difference shall (except as to any matters, the decision of which is specifically provided for therein) be referred to the sole arbitration of the arbitrator appointed by BHEL/In charge.

The award of the Arbitrator shall be binding upon the parties to the dispute Subject as aforesaid, the provisions of Arbitration and Reconciliation Act 1996 (India) or statutory modifications or reenactments thereof and the rules made there under and for the time being in force shall apply to the arbitration proceedings under this clause. The venue of the arbitration shall be the place from which the contract is issued or such other place as the Arbitrator at his discretion may determine

2.18.2 In case of Contract with Public Sector Enterprise (PSE) or a Government Department, the following shall be applicable:

In the event of any dispute or difference relating to the interpretation and application of the provisions of the Contract, such dispute or difference shall be referred to by either party to the arbitration of one of the arbitrators in the department of public enterprises. The award of the arbitrator shall be binding upon the parties to the dispute, provided, however, any party aggrieved by such award may make further reference for setting aside or revision of the award to the Law Secretary, Department of Legal Affairs, Ministry of Law and Justice, Government of India. Upon such reference the dispute shall be decided by the Law Secretary or the Special Secretary or Additional Secretary when so authorized by the Law Secretary, whose decision shall bind the parties hereto finally and conclusively.

2.18.3 The cost of arbitration shall be borne equally by the parties.

2.18.4 Work under the contract shall be continued during the arbitration proceedings

2.19 PAYMENTS

Payments to Contractors are made in any one of the following forms

2.19.1 Running Account Bills (RA Bills)

i) These are for interim payments when the contracts are in progress. The bills for such interim payments are to be prepared by Contractor in prescribed formats (RA Bill forms).

ii) Payments shall be made according to the extent of work done as per measurements taken up to the end of the calendar month and in line with the terms of payments described in the Tender documents along with relevant statutory documents applicable for the work.

iii) Recoveries on account of electricity, water, statutory deductions, etc are made as per terms of contract

iv) Full rates for the work done shall be allowed only if the quantum of work has been done as per the specifications stipulated in the contract. If the work is not executed as per the stipulated specifications, BHEL may ask the contractor to re do the work according to the required specifications, without any extra cost. However, where this is not considered necessary 'OR' where the part work is done due to factors like non-availability of material to be supplied by BHEL 'OR' non availability of fronts 'OR' non availability of drawings, fraction payment against full rate, as is considered reasonable, may be allowed with due regard for the work remaining to be done. BHEL decision in this regard will be final and binding on the contractor.

v) In order to facilitate part payment, BHEL Site Engineer at his discretion may further split the contracted rates/percentages to suit site conditions, cash flow requirements according to the progress of work

2.19.2 Final Bill

Final Bill is used for final payment on closing of Running Account for works or for single payment after completion of works. *Final Bill* shall be submitted as per prescribed format after completion of works as per scope and upon material reconciliation, along with the following.

i) *No Claim Certificate* by contractor

ii) *Clearance certificates* where ever applicable viz *Clearance Certificates* from Customer, various *Statutory Authorities* like Labour department, PF Authorities, Commercial Tax Department, etc

iii) *Indemnity bond* as per prescribed format BHEL shall settle the final bills after deducting all liabilities of Contractor to BHEL

2.20 PERFORMANCE GUARANTEE FOR WORKMANSHIP

2.20.1 Even though the work will be carried out under the supervision of BHEL Engineers the Contractor will be responsible for the quality of the workmanship and shall guarantee the work done for a period of as mentioned in the contract/NIT from the date of commencement of guarantee period as defined in Technical Conditions of Contract, for good workmanship and shall rectify free of cost all defects due to faulty erection detected during the guarantee period. In the event of the Contractor failing to repair the defective works within the time specified by the Engineer, BHEL may proceed to undertake the repairs of such defective works at the Contractor's risk and cost, without prejudice to any other rights and recover the same from the balance security deposit.

2.20.2 BHEL shall release the balance security deposit subject to the following

i) Contractor has submitted *Final Bill*

ii) *Guarantee period* as per contract has expired

iii) Contractor has furnished *No Claim Certificate* in specified format

iv) BHEL Site Engineer/Construction Manager has furnished the *No Demand Certificate* in specified format

v) Contractor has carried out the works required to be carried out by him during the period of Guarantee and all expenses incurred by BHEL on carrying out such works is included for adjustment from the Guarantee money refundable.

2.21 CLOSING OF CONTRACTS

The Contract shall be considered completed and closed upon completion of all contractual obligations and settlement of Final Bill or completion of Guarantee period whichever is later. Upon closing of Contract, BHEL shall issue a completion certificate as per standard format, based on specific request of Contractor.

2.22 REVERSE AUCTION/PRICE BID OPENING:

- BHEL reserves the right to go for reverse auction at any point of time before opening of Price Bid.
- Bids with non-acceptance of reverse auction will be liable for rejection.
- Opening of Price Bid at discretion of BHEL.
- BHEL shall be at liberty to cancel the tender at any time, before ordering, without assigning any reason.

2.23 SUSPENSION OF BUSINESS DEALINGS

BHEL reserves the right to take action against Contractors who either fail to perform or Tenderers/Contractor who indulge in malpractices, by suspending business dealings with them in line with BHEL guidelines issued from time to time.

2.24 OTHER ISSUES

2.24.1 Value of Non judicial Stamp Paper for Bank Guarantees and for Contract Agreement shall be not less than Rs 200/- unless otherwise required under relevant statutes.

2.24.2 In case of any conflict between the General Conditions of Contract and Special Conditions of Contract, provisions contained in the Special Conditions of Contract shall prevail.

2.24.3 Unless otherwise specified in NIT, offers from consortium /JVs shall not be considered.

2.24.4 BHEL may not insist for signing of Contract Agreements in respect of low value and short time period contracts

COPYRIGHT AND CONFIDENTIAL

THE INFORMATION ON THIS DOCUMENT IS THE PROPERTY OF BHARAT HEAVY ELECTRICALS LTD. IT MUST NOT BE USED DIRECTLY OR INDIRECTLY IN ANY WAY DETRIMENTAL TO THE INTEREST OF THE COMPANY.

DRG. No. BHEL-GSECL-R2-CIV-DRAIN-018

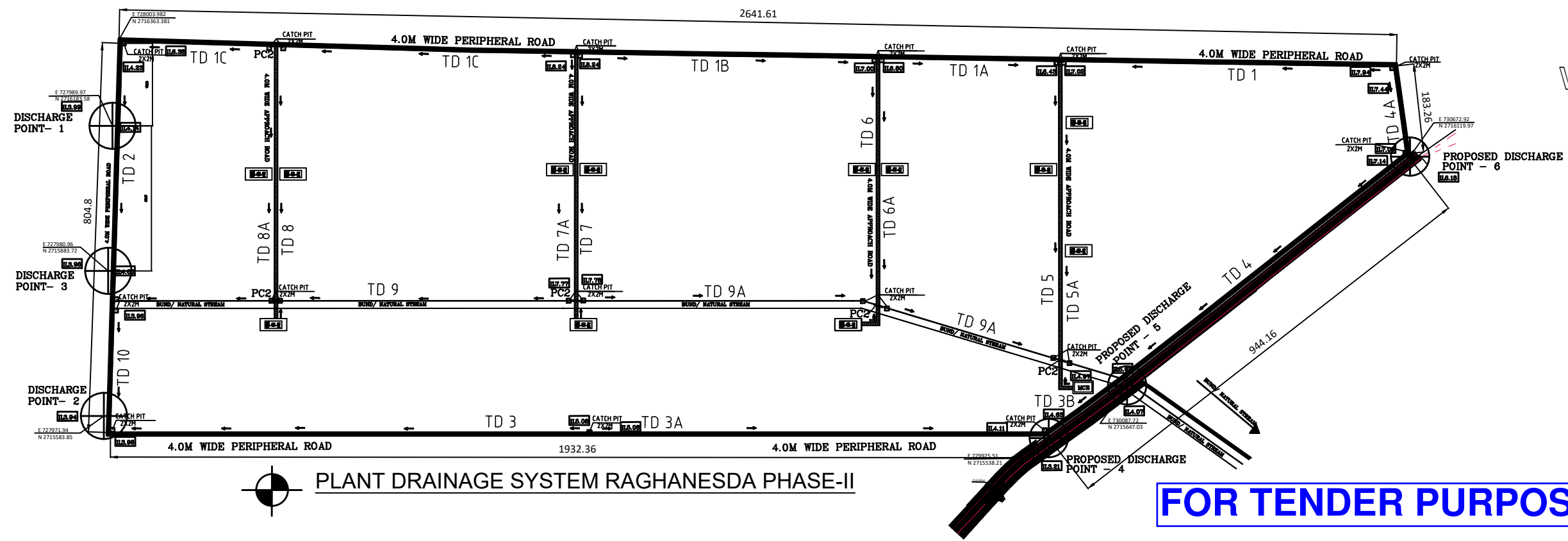
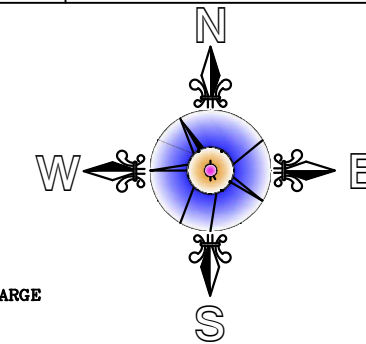

PLANT DRAINAGE SYSTEM RAGHANESDA PHASE-II

FOR TENDER PURPOSE ONLY

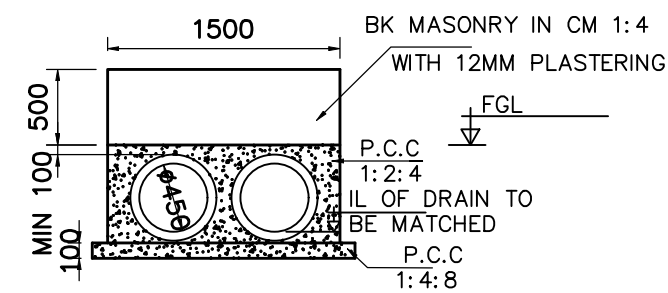

SECTION B-B FOR (PC-1)

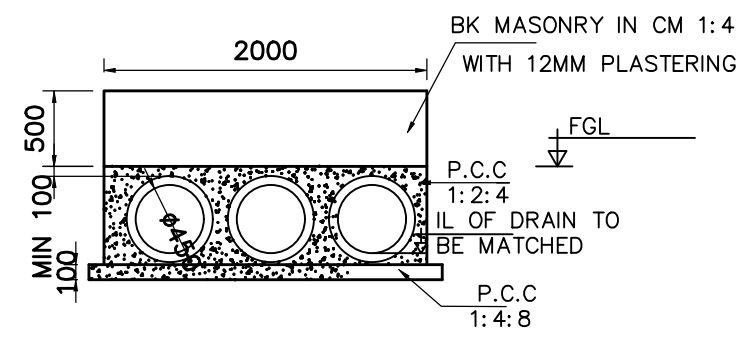

SECTION B-B FOR (PC-2)

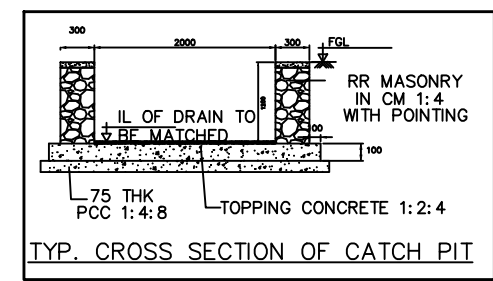

TYP. CROSS SECTION OF CATCH PIT

LEGEND	
	- DRAIN
	- FLOW DIRECTION AFTER LAND GRADING
	- TRAPEZOIDAL DRAIN NO
	- PIPE CULVERT
	- OUTFALL
	- FINISHED ROAD LEVEL
	- FINISHED GROUND LEVEL
	- WATER BOUND MACADAM

REFERENCE
PLOT DRAWING NO : BHEL-GSECL-R2-CIV-PLOT_PLAN-003

- NOTES**
1. ALL DIMENSIONS ARE IN MILLIMETERS AND LEVELS ARE IN METRES UNLESS NOTED OTHERWISE.
 2. DRAWING SHOULD NOT BE SCALED.
 3. GRADE OF CONCRETE SHALL BE OF M25.
 4. REINFORCEMENT STEEL SHALL BE OF Fe415 CRS GRADE, CONFORMING TO IS
 5. MINOR MODIFICATIONS OF DRAIN & PIPE CULVERT SHALL BE MADE SUIT TO SITE CONDITION.
 6. FRL OF ROADS SHALL BE MINIMUM 150MM ABOVE FGL.
 7. THE SHOULDERS SHALL BE MADE USING USABLE EXCAVATED SOIL/EARTH AT SITE OR FROM BORROW AREA AND SHALL BE FORMED IN LAYERS TO ACHIEVE 97% COMPACTION. NO EXPANSIVE SOIL SHALL BE USED.
 8. LONGITUDINAL SLOPE OF PIPE SHOULD BE MINIMUM OF 1 IN 2000
 9. RECTANGULAR DRAINS TD1 HAVE BEEN PROVIDED TO LEAD THE DRAIN UPTO OUTFALL OF THE PLANT.
 10. ALL R.C.C. PIPE OF NP3 TYPE CONFORMING TO I.S. 458:2013
 11. DRAIN WEEP HOLES SHALL BE PROVIDED WITH PVC PIPES AT 5M INTERVAL.

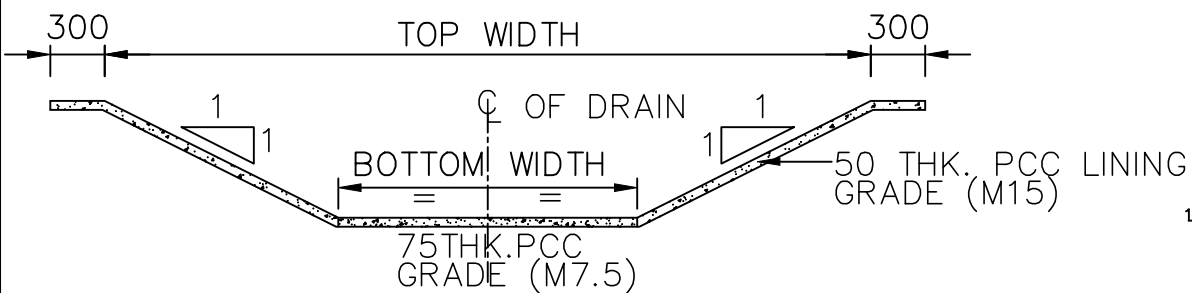

TYPICAL DETAIL OF PERIPHERAL DRAIN / INTERNAL DRAIN

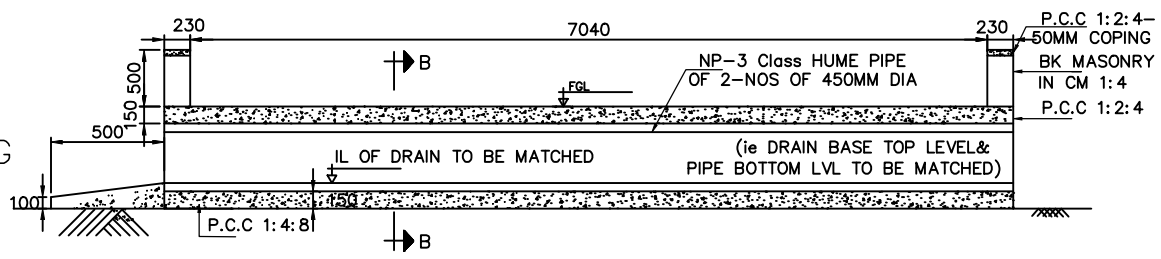

LONGITUDINAL SECTION OF PIPE CULVERT

PROJECT TITLE: GSECL 100 MW SOLAR PV PROJECT RAGHANESDA PH-II

BHARAT HEAVY ELECTRICALS LIMITED.
ELECTRONICS DIVISION, BANGALORE

TITLE:	PLANT DRAINAGE SYSTEM - LAYOUT AND CROSS SECTIONAL DETAILS	No. OF SHEETS	01
		SHEET No.	01
		REV	01

REV.	DATE	ALTERED	REV.	DATE	ALTERED	DRAWN	NAME	SIGN	DATE
		CHECKED			CHECKED				
		APPROVED			APPROVED				
			01.10.20				S.R		02.03.21
						CHECKED	T.C		
						APPROVED	T.C		
						DISTRIBUTION OF PRINTS		DEPT.	CODE



BHEL DRG. No. BHEL-GSECL-R2-CIV-DRAIN-018

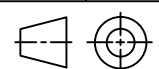

REF. DRG. No.

SIGN. & DATE

INVENTORY No.

1 2 3 4

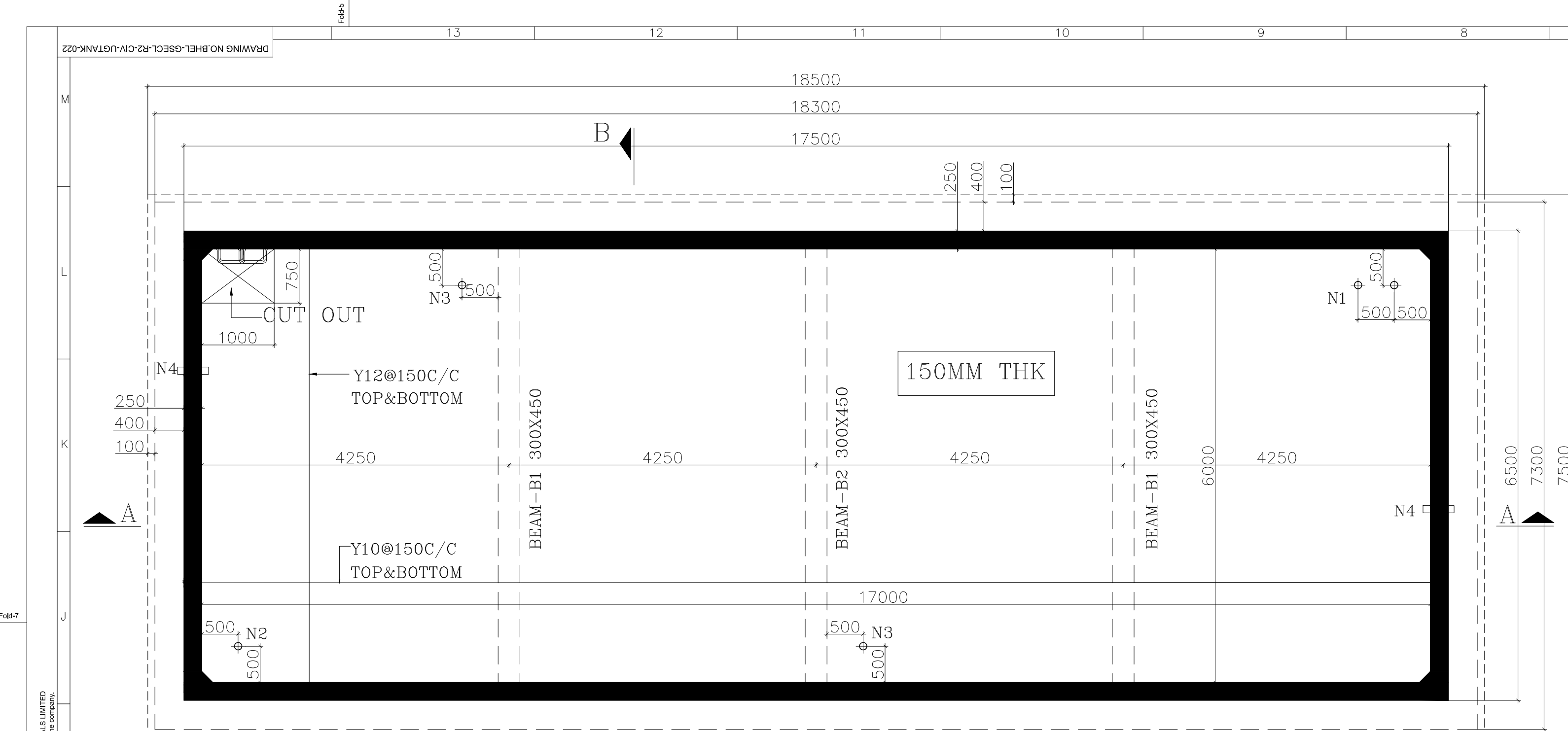

TOP SLAB PLAN @ +0.500 LVL (TOC)
T=150MM UNLESS SPECIFIED

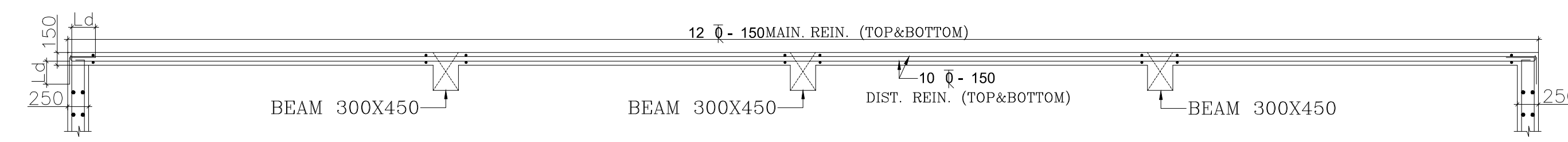

C/S OF ROOF SLAB(150MM THK) DETAIL

FOR TENDER PURPOSE ONLY

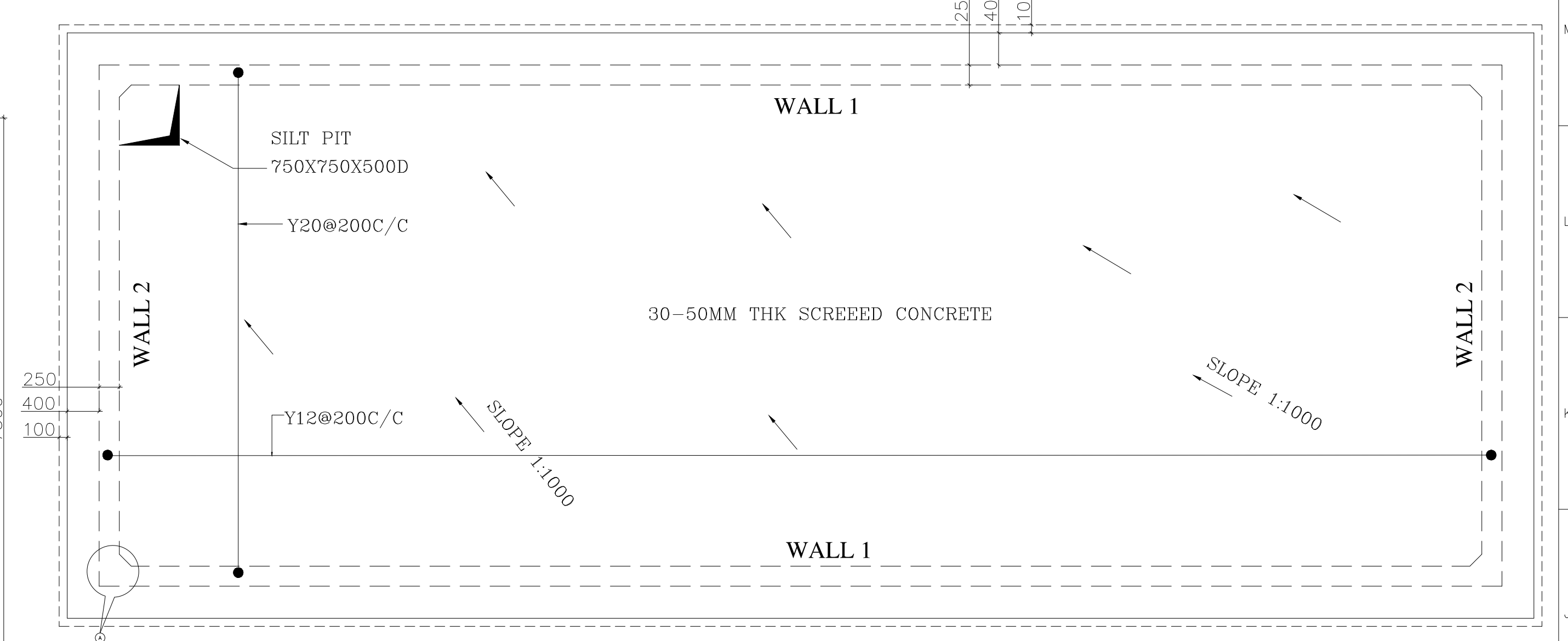

BASE SLAB BOTTOM REINFORCEMENT DETAILS
SLAB THICKNESS = 500MM
(PLAN)

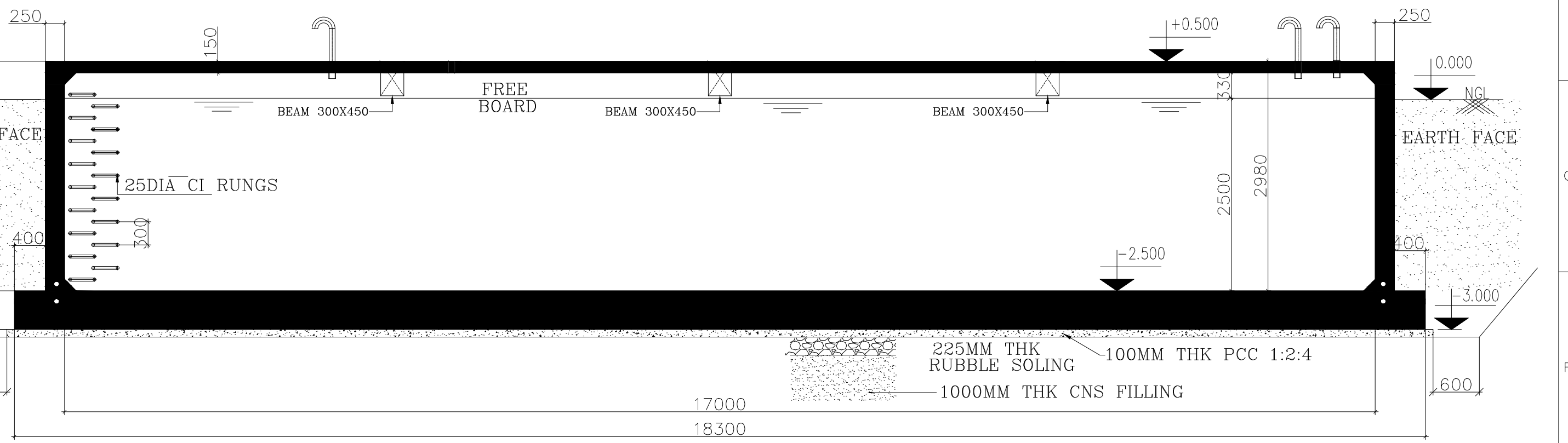

SECTION A-A

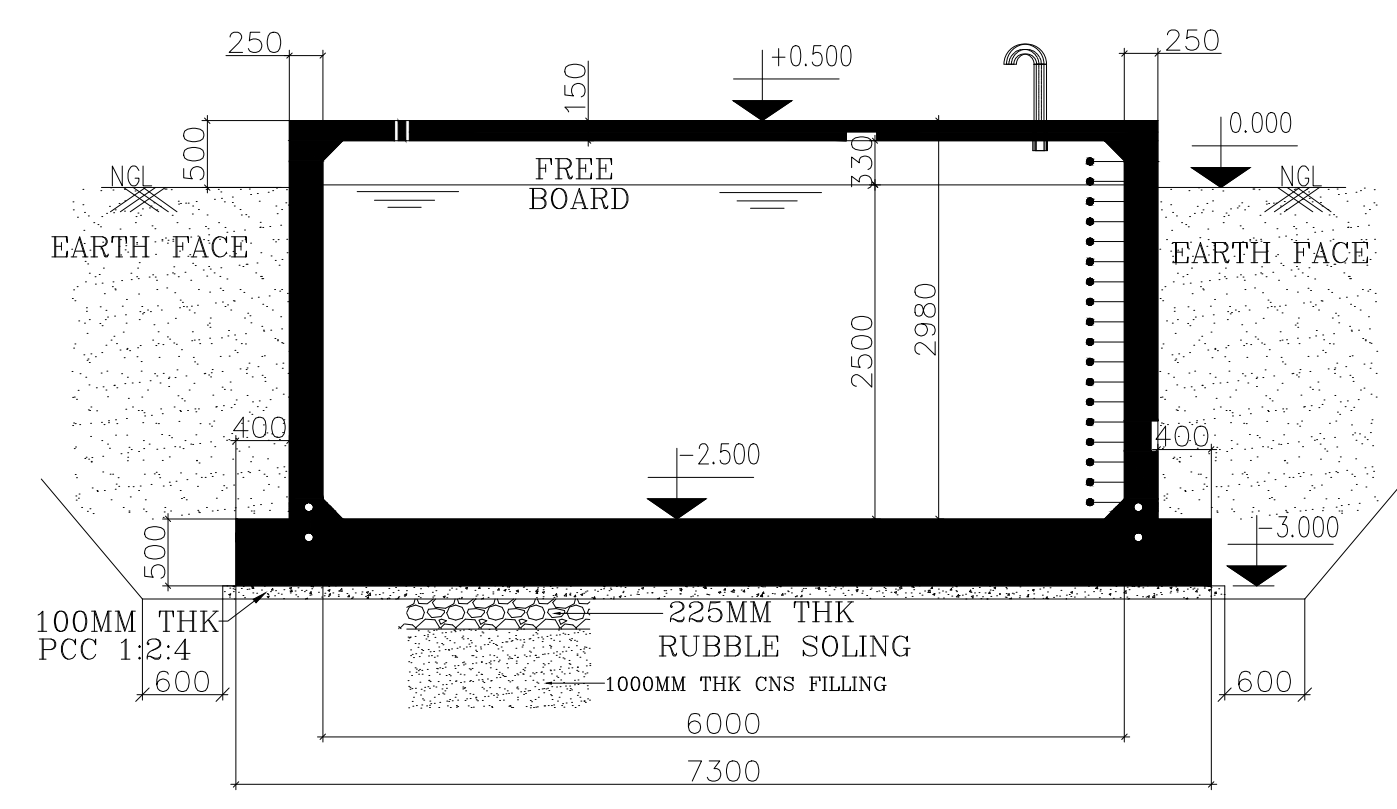

SECTION B-B

- NOTES
- THIS DRAWING SHALL BE READ IN CONJUNCTION WITH TECHNICAL SPECIFICATION.
 - ALL DIMENSIONS ARE IN MM.
 - MINIMUM PCC GRADE SHALL BE OF M15(1:2:4).
 - MINIMUM CONCRETE GRADE SHALL BE OF M30.
 - ALL REINFORCEMENT SHALL BE OF HIGH YIELD STRENGTH DEFORMED BARS (FE-415 CRS) CONFORMING TO IS.
 - CLEAR COVER SHALL BE 25MM.
 - BENT LENGTH SHALL BE AS PER SP34 & IS 2502.
 - DEVELOPMENT LENGTH "LD" & LAP LENGTH SHALL BE TAKEN AS 50 X DIA OF THE BAR UNLESS SPECIFIED.
 - ALL CONSTRUCTION WORK SHALL BE EXECUTED IN ACCORDANCE WITH RELEVANT IS CODES.
 - THE DEPTH OF FOUNDATION SHALL BE TAKEN FROM NGL.
 - ALL EXTERNAL PLASTER SURFACE SHALL BE AINTEG USING TWO COATES OF ASIAN MAKE ACE PAINT OVER ONE COAT OF PRIMER. (FOR WALLS ABOVE GL & COVER SLAB)
 - CONCRETE FOR THE UGWT SHALL HAVE PLASTICISER CUM WATERPROOFING CEMENT ADDITIVES CONFORMING TO IS:9103
 - THE OUTER FACE SHALL BE PROVIDED WITH MIN. TWO COATES OF BITUMINOUS PAINTING OF GRADE 85/25 CONFIRMING TO IS:702 @ 1.7KG PER Sq.m FOR WATER/DAMP PROOFING.(FOR WALLS BELOW GL)
 - BELOW THE FLOOR SLAB 100THK. PCC, 225THK. RUBBLE SOLING AND 1000THK. CNS MATERIAL SHALL BE PROVIDED.
 - IF ROCK STRATA IS FOUND AT PCC LEVEL NO CNS SHALL BE PROVIDED
 - MINIMUM CEMENT CONTENT AS PER IS:3370(2009)
 - BACKFILLING SHALL BE ONLY AFTER CASTING OF TOP SLAB AND ACHIEVING OF ITS FULL STRENGTH
 - SBC = 10.71T/Sq.m@2.0m DEPTH FROM NGL AS PER SOIL INVESTIGATION REPORT.
 - ALL CUT-OUT LOCATIONS SHALL BE REFERRED FROM APPROVED PLUMBING DRAWINGS
 - 6MM THICK CHEKERED PLATE SHALL BE PROVIDED AS MANHOLE COVER
 - HAUNCH BAR EXTENSION SHALL BE 150MM(TYP); EXTENSION OF BAR IN ADJACENT WALL AND EXTENSION OF FLOOR R/F INTO WALL SHALL BE Ld UNLESS SPECIFIED SPECIFICALLY

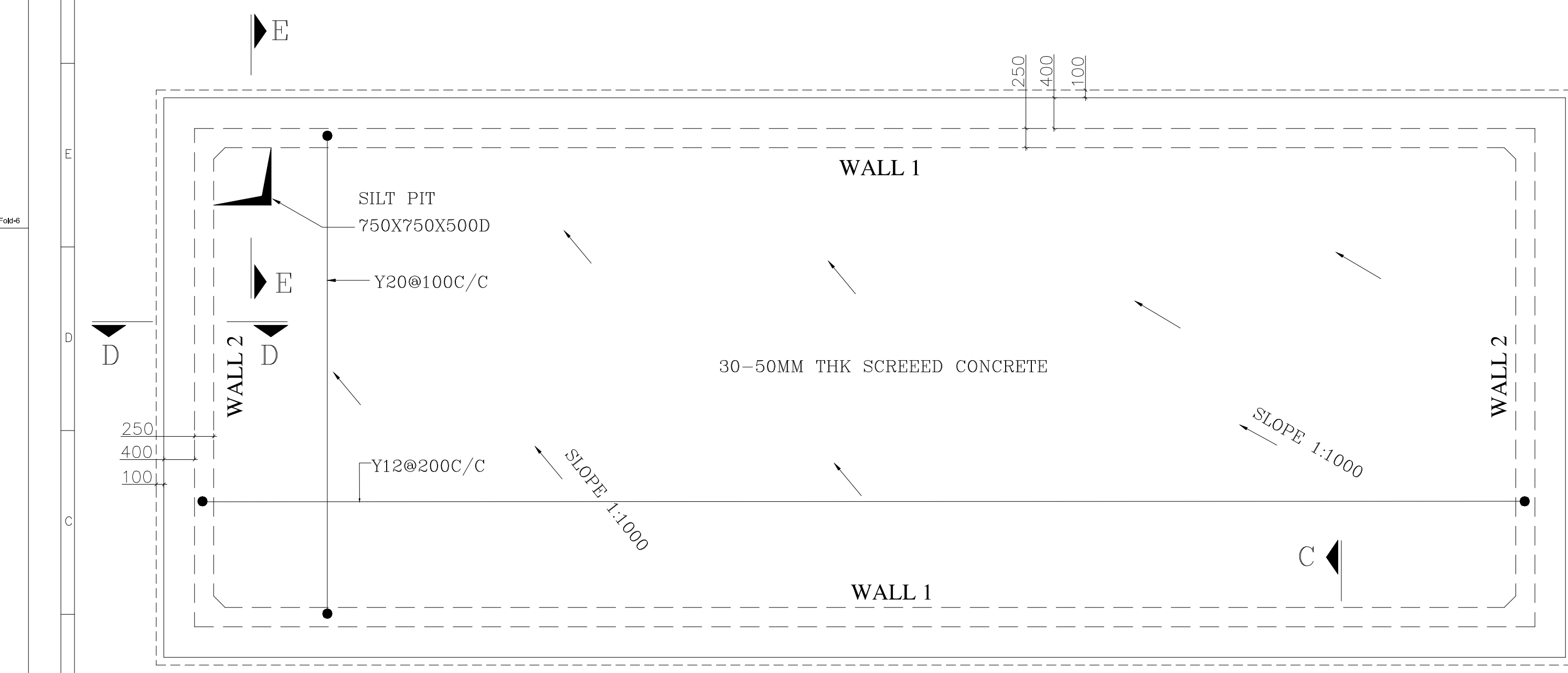

BASE SLAB TOP REINFORCEMENT DETAILS
SLAB THICKNESS = 500MM
(PLAN)

NOZZLE SCHEDULE							CL. = CENTRE LINE FOF = FACE OF FLANGE	
MARK NO	DESCRIPTION	'A' NB PIPES	'B' NB FLANGE	'C' SQ. BLK. 8 THK. PLATE	'D' ELEVATION OF NOZZLE	QTY.	M.O.C.	
N1	INLET	100	100	225	TOP OF SLAB	2NOS.	MS	
N2	OUTLET	100	100	250	TOP OF SLAB	1NO.	MS	
N3	VENTS	150	150	270	TOP OF SLAB	2NOS.	MS	
N4	OVERFLOW	40	40	150	CL +0.1 M	2NOS.	MS	

PROJECT: 100MWp SOLAR PV PLANT AT RAGHANESDA PH-II,GUJARAT

OWNER: GUJARAT STATE ELECTRICITY CORPORATION LIMITED

DEPT. SC&PV
STATUS CONTRACT
DISTRIBUTION

CONTRACTOR: BHARAT HEAVY ELECTRICALS LTD
ELECTRONICS DIVISION, BANGALORE

TITLE: DETAILS OF 2.5L LITRE UNDERGROUND WATER TANK

SCALE 1:100 DRAWING NO. BHHEL-GSCL-R2-CIV-UGTANK-022
SHEET 01 OF 02 REV. 00

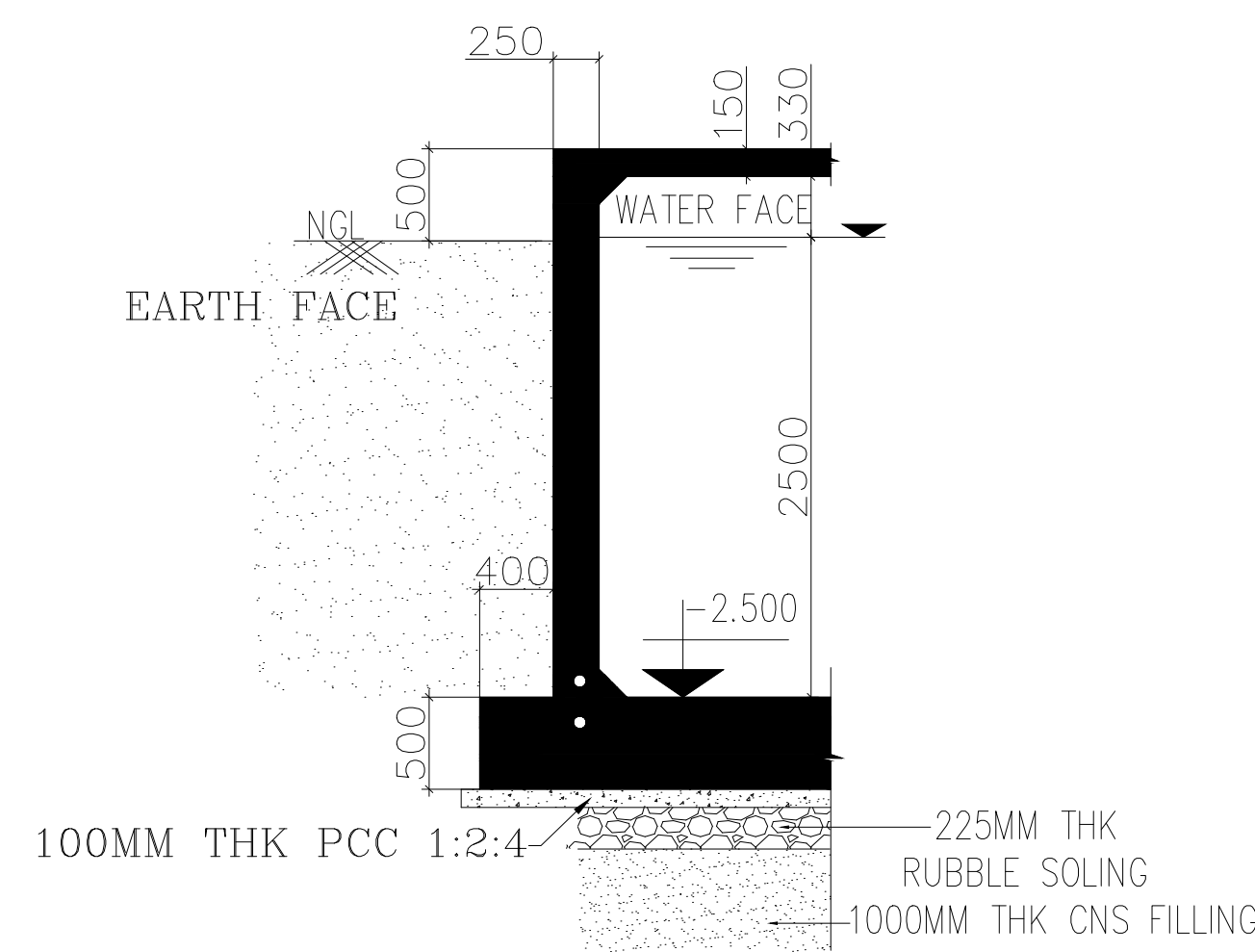

CONCRETE DIMENSION
WALL-1&2 DETAILS

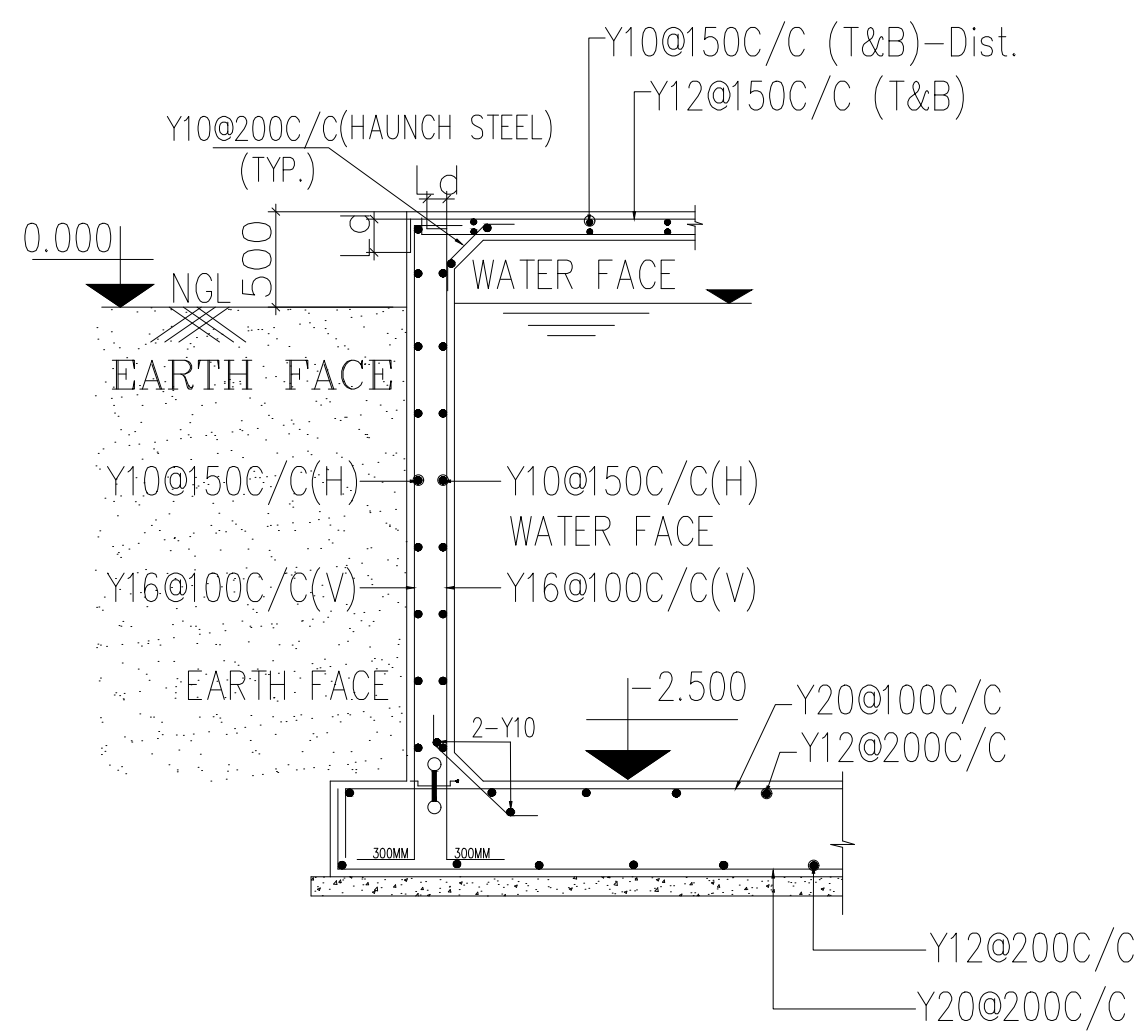

WALL-1 DETAIL SEC-CC
REINFORCEMENT DETAIL

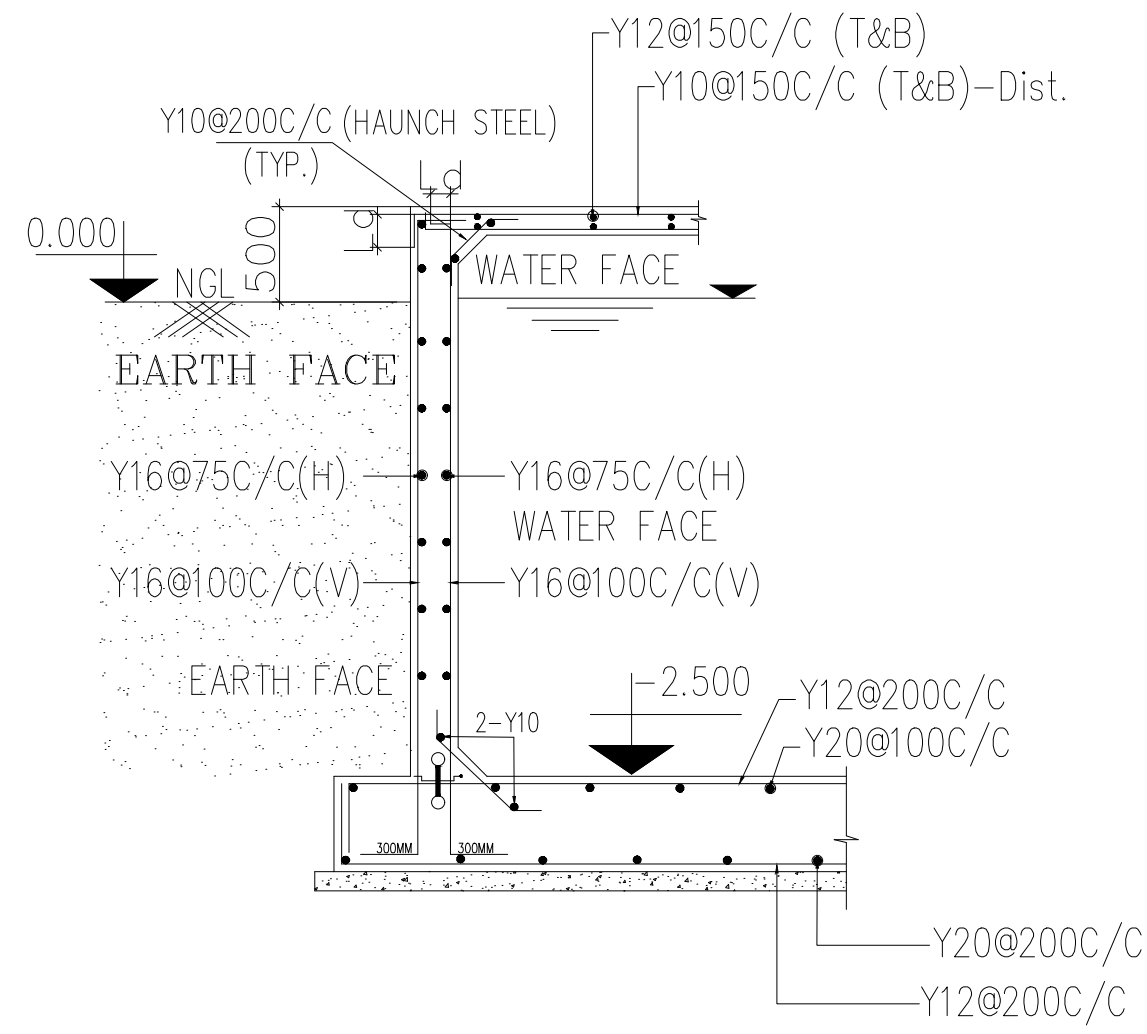

WALL-2 DETAIL SEC-DD
REINFORCEMENT DETAIL

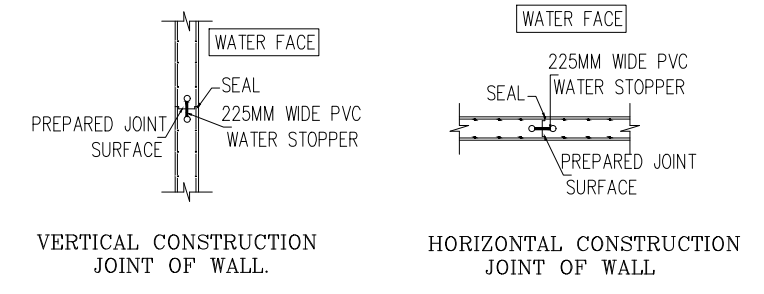

SCHEDULE OF COVER SLAB BEAMS (SCALE 1:25)		
BEAM MARK	SUPPORT	MID SPAN
B1		

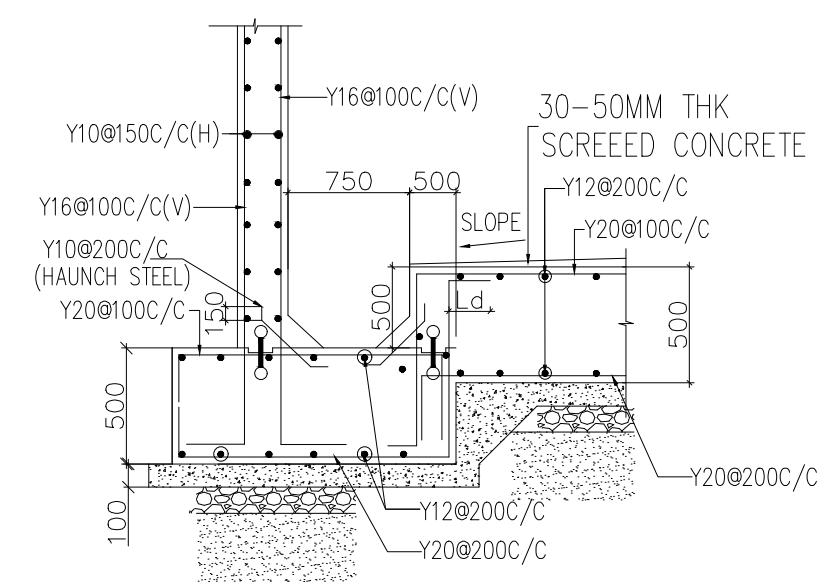

SILT PIT DETAIL
SECTION E-E

FOR TENDER PURPOSE ONLY

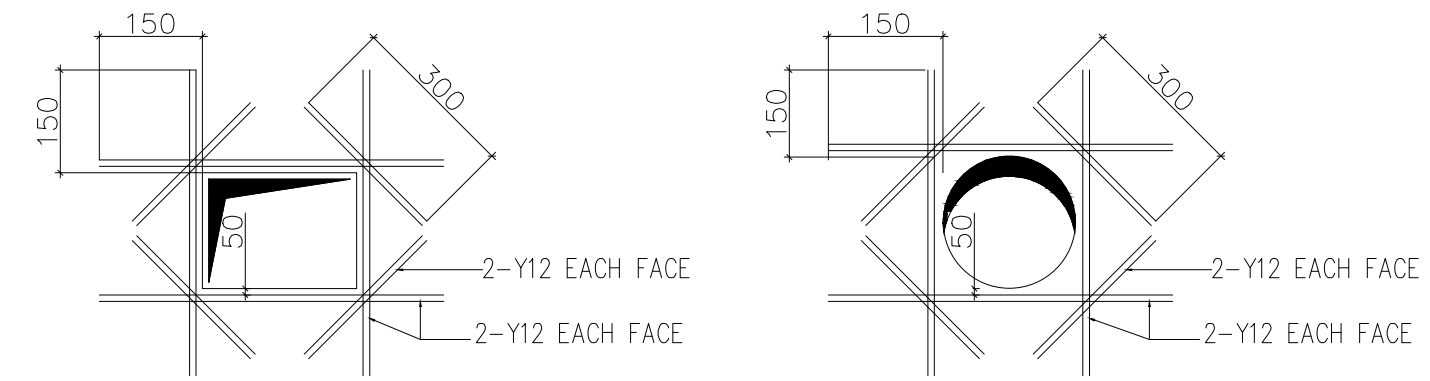
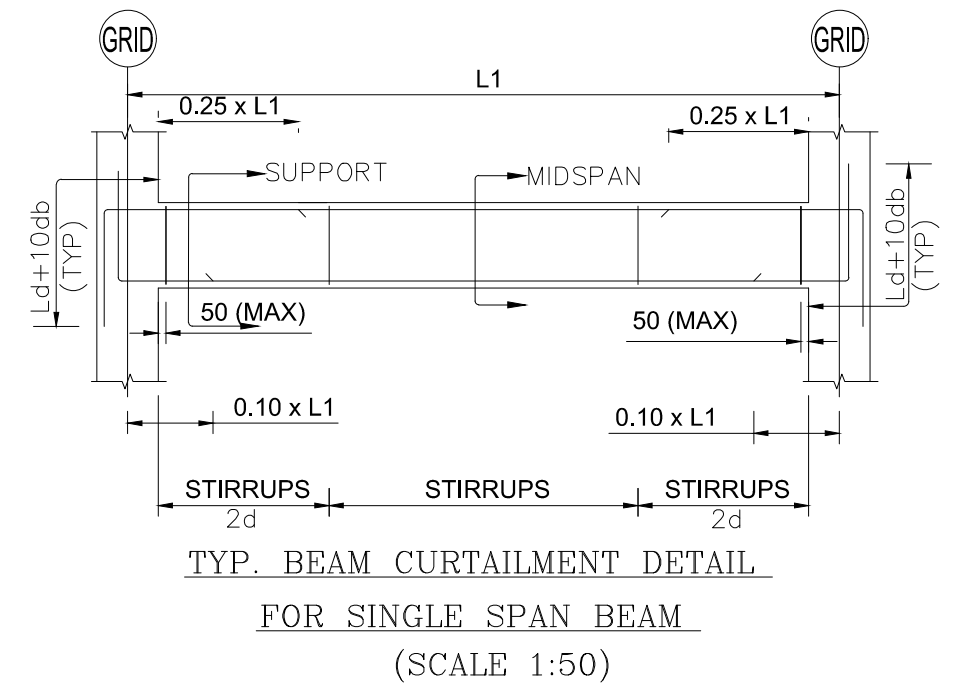
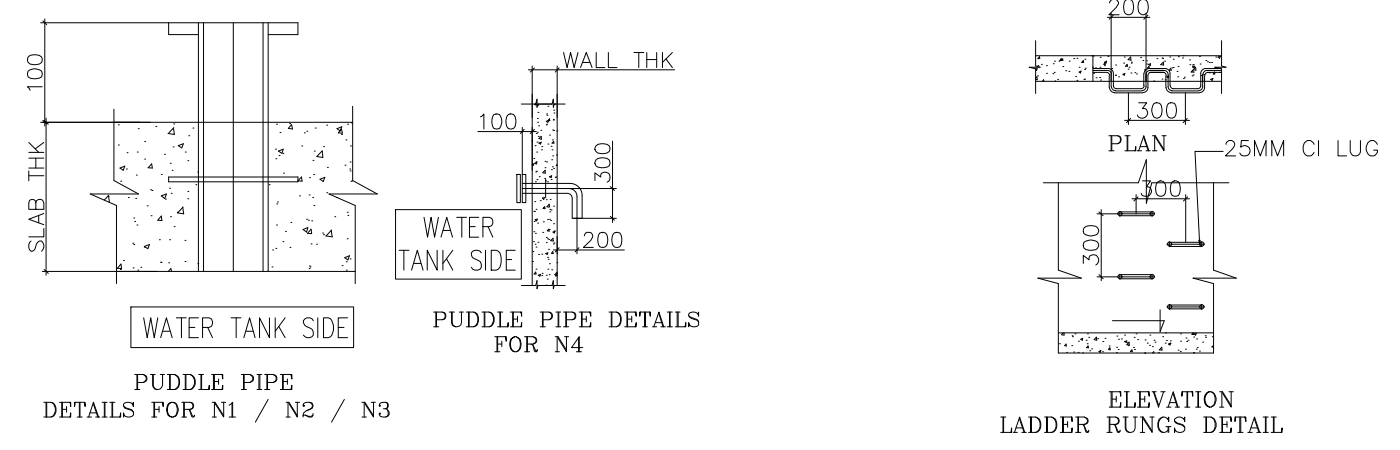

TYPICAL OPENING DETAIL

- NOTES
- THIS DRAWING SHALL BE READ IN CONJUNCTION WITH TECHNICAL SPECIFICATION.
 - ALL DIMENSIONS ARE IN MM.
 - MINIMUM PCC GRADE SHALL BE OF M15(1:2:4).
 - MINIMUM CONCRETE GRADE SHALL BE OF M30.
 - ALL REINFORCEMENT SHALL BE OF HIGH YIELD STRENGTH DEFORMED BARS (FE-415 CRS) CONFORMING TO IS.
 - CLEAR COVER SHALL BE 25MM.
 - BENT LENGTH SHALL BE AS PER SP34 & IS 2502.
 - DEVELOPMENT LENGTH "LD" & LAP LENGTH SHALL BE TAKEN AS 50 X DIA OF THE BAR UNLESS SPECIFIED.
 - ALL CONSTRUCTION WORK SHALL BE EXECUTED IN ACCORDANCE WITH RELEVANT IS CODES.
 - THE DEPTH OF FOUNDATION SHALL BE TAKEN FROM NGL.
 - ALL EXTERNAL PLASTER SURFACE SHALL BE AINTE USING TWO COATES OF ASIAN MAKE ACE PAINT OVER ONE COAT OF PRIMER. (FOR WALLS ABOVE GL & COVER SLAB)
 - CONCRETE FOR THE UGWT SHALL HAVE PLASTICISER CUM WATERPROOFING CEMENT ADDITIVES CONFORMING TO IS:9103
 - THE OUTER FACE SHALL BE PROVIDED WITH MIN. TWO COATS OF BITUMINOUS PAINTING OF GRADE 85/25 CONFIRMING TO IS:702 @ 1.7KG PER Sq.m FOR WATER/DAMP PROOFING.(FOR WALLS BELOW GL)
 - BELOW THE FLOOR SLAB 100THK. PCC, 225THK. RUBBLE SOLING AND 1000THK. CNS MATERIAL SHALL BE PROVIDED.
 - IF ROCK STRATA IS FOUND AT PCC LEVEL NO CNS SHALL BE PROVIDED
 - MINIMUM CEMENT CONTENT AS PER IS:3370(2009)
 - BACKFILLING SHALL BE ONLY AFTER CASTING OF TOP SLAB AND ACHIEVING OF ITS FULL STRENGTH
 - SBC = 10.71T/Sq.m@2.0m DEPTH FROM NGL AS PER SOIL INVESTIGATION REPORT.
 - ALL CUT-OUT LOCATIONS SHALL BE REFERRED FROM APPROVED PLUMBING DRAWINGS
 - 6MM THICK CHEKERED PLATE SHALL BE PROVIDED AS MANHOLE COVER
 - HAUNCH BAR EXTENSION SHALL BE 150MM(TYP); EXTENSION OF BAR IN ADJACENT WALL AND EXTENSION OF FLOOR R/F INTO WALL SHALL BE Ld UNLESS SPECIFIED SPECIFICALLY

DEPT. SC&PV		PROJECT- 100MWp SOLAR PV PLANT AT RAGHANESDA PH-II,GUJARAT	
STATUS CONTRACT		OWNER- GUJARAT STATE ELECTRICITY CORPORATION LIMITED	
DISTRIBUTION		EPC CONTRACTOR- BHARAT HEAVY ELECTRICALS LTD ELECTRONICS DIVISION, BANGALORE	
REV. 01	DATE 11.09.20	DRAWN BY	APPD BY
TITLE DETAILS OF 2.5LITRE UNDERGROUND WATER TANK			
SCALE 1:100		DRAWING NO. BHHEL-GSBCI-R2-CIV-UGTANK-022	
SHEET 02 OF 02		REV. 00	

FIELD QUALITY PLAN (FQP-CIVIL) FOR 100 MW_p SOLAR PV PROJECT - GSECL RAGHANESDA PHASE-II

Sl. No	Activity and operation	Characteristics / instruments	Class of Check	Type of Check	Quantum Of check	Reference Document	Remarks
1	2	3		4	5	6	7
1.0	EXCAVATION AND FILLING IN FOUNDATION WORKS (For Buildings, Transformer foundation, Cable Trench, Drains, Switch Yard, Water Tank ,Fencing and Septic Tank)						
	Excavations-						
1.1		Nature, type of soil/rock before and during excavations	As required	C	Visual	Random in each shift	Tech Specs or Const. Drawings
1.2		Initial ground level before start of excavations	As required	C	Measurement	100%	Tech Specs or Const. Drawings
1.3		Final shape and Dimensions of excavations.	As required	C	Measurement	100%	Tech Specs or Const. Drawings
1.4		Final excavation levels	As required	B	Measurement	100%	Tech Specs or Const. Drawings
	Filling						
1.5	Standard proctor Test	Optimum moisture content and max. dry density before fill	As per IS: 2720, Proctor needle apparatus,etc.	B	Physical	Once for each source & for every change of source	IS 2720 (Pt.VII), Tech Specs and Const. Drawings
1.6	Degree Of Compaction Of Filling						
i		Dry density by core cutter method	As per IS: 2720/compaction test (core cutter), balance, rapid moisture meter etc.	A	Physical	One Sample in every 2000 SQm area for each compacted layer	IS 2720 (Pt. XXIX), Tech Specs and Const. Drawings
2.0	MATERIALS						
2.1	CEMENT (43 grade only)						
i		cement	as per IS:4031	A	Review of MTC	For each lot received at site	As per relevant IS Codes & Each consignment of cement shall be duly correlated with manufactureres TC.
ii		Retesting of cement	as per IS:4031	A	Testing in NABL accredited Lab/Govt. Engg institutes only	For each lot received at site	As per relevant IS Codes & Each consignment of cement shall be duly correlated with manufactureres TC. If cement bags are stored for more than 3 months
2.2	Coarse Aggregate						
ii		Moisture content	as per IS:2386	A	Physical	Once for each source & for every change of source	IS : 456 IS : 383/Tech Spec Along with design mix
iii		Specific gravity, water absorption	IS:2386	A	Physical	Once for each source & for every change of source	IS: 2386 Part-III, IS:456, IS:383/Tech Spec Along with design mix
iii		Sieve analysis, flakiness index, elongation index,	IS:2386	A	Physical	Once for each source & for every change of source	IS: 2386 Part-I, IS:383/Tech Spec Along with design mix
iv		Deleterious materials (coal & lignite, clay lumps, material finer than 75 micron sieve, soft fragment, shale)	IS:2386	A	Physical	Once per source/ on every change of source	IS: 2386 Part-II, IS:383/Tech Spec Along with design mix
v		Soundness	IS:2386	A	Physical	-do-	IS: 2386 Part-V, IS:383 Along with design mix
vi		Impact value test	IS:2386	A	Physical	-do-	IS:383, IS-2386 Part IV/Tech Spec Along with design mix
2.3	Fine Aggregate						
i		Moisture content	balance , oven, rapid moisture meter etc	A	Physical	To be done every day before start of work	IS: 2386 Part-III, IS:383 Along with design mix
ii		Deleterious materials (coal & lignite, clay lumps, material finer than 75 micron sieve, soft fragment, shale)	IS:2386	A	Physical	Once per source& for on every change of source	IS: 2386 Part-II, IS:383 Along with design mix

FIELD QUALITY PLAN (FQP-CIVIL) FOR 100 MW_p SOLAR PV PROJECT - GSECL RAGHANESDA PHASE-II

Sl. No	Activity and operation	Characteristics / instruments		Class of Check	Type of Check	Quantum Of check	Reference Document	Remarks
1	2	3			4	5	6	7
2.4	Water							
i		Complete tests as per IS:456	as per IS:456	B	Testing	One for each source.	IS:3025 part 22 and 23 (for test procedure), IS:456(for acceptance criteria)	Along with design mix
2.5	CONCRETE (For Buildings, Transformer foundation, Cable Trench, Drains, Switch Yard, Water Tank,Fencing and Septic Tank)							
i		Compressive strength (works Tests cubes)	IS:516	A	Physical	One set of 6 cubes per 50 CuM or part thereof for M25 grade of concrete.	IS:516, IS:456.	Min. of 6 cubes for each sift shall be taken where the concrete quantity is low.
ii		Workability - slump test	IS:1199	A	Physical	At the time of concrete pouring at site	IS:456	
2.5.1	RMC CONCRETE	Design mix and cube test	IS:516	A	Physical	Review and approval of concrete mix design report from RMC supplier,Review and approval of concrete mix design reports for periodic cube tests from the supply	IS:456	
2.5.2	Admixtures for Concrete	Type of admixture	As per IS:9103	A	Review of MTC	For each lot received at site	Designed mix and IS:9103	*MTC = Manufacturer's Test Certificate
2.6	REINFORCEMENT STEEL							
i		Physical & Chemical Properties.	As required	A	Review of MTC	For each lot received at site	IS : 1786, IS:432, IS:1566, Tech Specs and Const. Drawings	1.Each consignment of steel shall be duly correlated with manufactureres TC. 2.TMT bars of grade Fe500D to be used
2.7	PLACEMENT OF REINFORCEMENT STEEL							
i		Bar bending schedule with necessary lap, Spacers & Chairs	As required	A	Visual & Measurement	Random in each shift	Approved Drawings, Tech Specs and Const. Drawings, IS:2502	
ii		Bending of bars, cutting tolerance	As required	B	Visual & Measurement	Random in each shift	Approved Drawings, Tech Specs and Const. Drawings, IS:2502	
iii		Acceptance - Cover, spacing of bars, spacers and chairs after the reinforcement cage is put inside the formwork	As required	A	Visual & Measurement	Random in each shift	Approved Drawings, Tech Specs and Const. Drawings	
2.8	STAGING AND FORMS							
i		Materials and accessories	As required	A	Visual	Once before start of work	As per relevant IS, Tech Specs and Const. Drawings	
ii		Soundness of staging, shuttering and scaffolding including application of mould oil / release agent	As required	A	Visual	Once before start of work	As per manufacturer's spec.and as per 3696,4014, 4990, Tech Specs and Const. Drawings	
iii		Acceptance of formwork before start of concreting		A	Physical / visual	Before start of each concreting	As per provisions and tolerances, Tech Specs and Const. Drawings	
2.9	BRICK MASONARY							
2.9.1	Test on Bricks							
		Dimensions , shape, compressive strength, water absorption, warpage, efflorescence.	As required	A	Measurement/ Physical Test/Testing in NABL accredited Lab/Govt. Engg institutes only	Once for each source & for every change of source	IS: 1077, IS:13757, IS: 12894 ,IS:2212,IS:3495/ Tech Specs and const. Drawings	Efflorescence shall be checked at each source.

FIELD QUALITY PLAN (FQP-CIVIL) FOR 100 MW_p SOLAR PV PROJECT - GSECL RAGHANESDA PHASE-II

Sl. No	Activity and operation	Characteristics / instruments		Class of Check	Type of Check	Quantum Of check	Reference Document	Remarks
1	2	3			4	5	6	7
2.9.2	Masonry construction	Workmanship, verticality and alignment	As required	A	Visual/ Physical	100%	IS 2212, IS 1905 , Tech Specs and Const. Drawings	
3.00 FINISHING AND ALLIED WORKS								
3.1 PLASTERING - WORKMANSHIP								
i		Curing	As required	C	Physical	100%	Tech specifications, construction drawings and agreed methodology	
ii		Thickness and finishing of plaster, grooves etc	As required	B	Visual/ Measurement	Random in each shift	Tech Specs and Const. Drawings	
iii		Truness of plastering system	As required	B	Visual/ Physical	Random in each shift	Tech Specs and Const. Drawings	
4.00 FENCING, GATES AND OTHER FINISHING WORKS								
4.1 Fencing and Gates								
i	GI Chain link mesh fabric, GI Concertina wire.	Materials	As required	B	Physical	Each batch of delivery	Tech Specs and Const. Drawings	
ii		Acceptance of the installation	As required	C	Physical / measurements	Each installation	Tech Specs and Const. Drawings	
4.2 FLOOR FINISHES AND ALIED WORKS								
4.2.1 Tiles								
i	Ceramic, vitrified, glass mosaic, acid alkali resistant, heavy duty cement concrete tiles	Materials	As required	A	Physical/Review of MTC	Each lot of delivery	Tech Specs and Const. Drawings	
ii		Finishing and acceptance	As required	A	Physical/Review of MTC	100%	Tech Specs and Const. Drawings	
4.2.2 Kota Stone, Granite and Marble								
i		Quality, texture, thickness, colour for each lot of delivery from approved source	As required	C	Physical	Each batch of delivery	Tech Specs and Const. Drawings	
ii		Finishing and acceptance	As required	B	Physical	100%	Tech Specs and Const. Drawings	
5.0 WATER SUPPLY / SANITORY INSTALLATIONS								
ii		Aceptance and leakage	As required	A	Acceptance/Review of MTC	Random	Tech Specs and Const. Drawings	
5.1 WATER PROOFING For Buildings								
		Methodology for the application of water proofing system	As required	B	Review / Review of MTC	for each type of treatment	Tech Specs and Const. Drawings	
5.1.1 General Requirement- 5 Layered Water Proofing								
i	Bitumen Primer	Material-Primer coat, finishing coat	As required	A	Physical / Review of MTC	For each batch received at site	Tech Specs /Const. Drawings	
ii	Binding material shall consists of Blown type bitumen of grade 85/25	Acceptance of water proofing work	As per IS:702	A	Physical / Review of MTC	For each batch received at site	Tech Specs and Const. Drawings	
iii	APP modified polymeric membrane		As required	A	Physical / Review of MTC	For each lot received at site	Tech Specs and Const. Drawings	
iv	Binding material shall consists of Blown type bitumen of grade 85/25		As per IS:702	A	Physical / Review of MTC	For each batch received at site	Tech Specs and Const. Drawings	

FIELD QUALITY PLAN (FQP-CIVIL) FOR 100 MW_p SOLAR PV PROJECT - GSECL RAGHANESDA PHASE-II

Sl. No	Activity and operation	Characteristics / instruments		Class of Check	Type of Check	Quantum Of check	Reference Document	Remarks
1	2	3			4	5	6	7
v	Brick tiles of CM 1:3		As required	A	Physical / Review of MTC	For each lot received at site	Tech Specs and Const. Drawings	
6.1	PAINTING SYSTEM - CONCRETE WORKS AND PLASTERED MASONRY SURFACES							
i	Materials and accessories- Oil Bound, Acrylic Emulsion, Chemical Resistant, Oil Resistant Paint etc.	Shade, type from brand and manufacturer as approved by BHEL/GSECL Civil Engineer	As agreed / required	A	BHEL/GSECL Approved source/Review of MTC	Invoice/DC from approved dealer/stockist	Tech Specs and Const. Drawings ,SR	
ii	Surface preparation	As required	As agreed / required	B	Physical /visual	Random in each shift	Tech Specs and Const. Drawings ,SR	
iii	Acceptance of painted surfaces	As required	As agreed / required	B	Physical	Each surface at random	Tech Specs and Const. Drawings ,SR	
6.1.1	PAINTING SYSTEM - STEEL WORKS (OTHER THAN STRUCTURAL STEEL WORKS)							
i		Painting Materials and accessories	-	A	BHEL/GSECL Approved source	Invoice/DC from approved dealer/stockist	Tech Specs and Const. Drawings,SR/DC/Invoice	
ii		Surface preparation	As agreed / required	A	Physical /visual	Applied area at random	Tech Specs and Const. Drawings, Relevant code/ standards ,SR	
iii		Acceptance of painted surfaces	As agreed / required	A	Visual and measurement	Applied area at random	Tech Specs and Const. Drawings,SR	
7.00	DOORS , WINDOWS VENTILATORS & GRILL							
7.1	Steel doors							
i		Materials (MS sheet, fasteners, hinges, jambs, lock strike plate etc	As agreed / required	C	Visual/ Physical dimensions report	For each lot received at site	IS 2062, IS 7452, IS 1081/ Tech Specs and Const. Drawings,SR / LB	Review of Manufacturer/Fabricator shop inspection report/Invoice/DC
ii		Flush Door shutters, teak beading	As agreed / required	C	BHEL/GSECL Approved source and review of DC/Invoice / Review of MTC	For each lot received at site	IS 2202, Tech Specs and Const. Drawings,SR	Review of Manufacturer/Fabricator shop inspection report/Invoice/DC
iii		Hollow metal doors (material and dimensions)	As agreed / required	C	Visual/ Physical dimensions report	For each lot received at site	Tech Specs and Const. Drawings	Review of Manufacturer/Fabricator shop inspection report/Invoice/DC
iv		Acceptance	As agreed / required	C	Visual/ Physical	Random	Tech Specs and Const. Drawings,SR/LB	
7.2	Aluminium works							
i		Materials- Aluminium sections	As agreed / required	B	Visual/ Physical dimensions report and review of Invoice/DC for source of approved make / Review of MTC	For each lot received at site	IS: 1948, IS: 1949, IS:733, IS1285, IS:1868, IS:11857/ Tech Specs and Const. Drawings,SR / LB	Review of Manufacturer/Fabricator shop inspection report/Invoice/DC
ii		Particle Door ,Toilet doors	As agreed / required	B	BHEL/GSECL Approved source and review of DC/Invoice / Review of MTC	For each lot received at site	IS:12823 (phenol formaldehyde sythetic resin, BWP type), FRP panels and frames, Tech Specs and Const. Drawings,SR	Review of Manufacturer/Fabricator shop inspection report/Invoice/DC
iii		Acceptance	As agreed / required	B	Visual/ Physical	Random	Tech Specs and Const. Drawings,SR	
7.3	Steel windows / Grills/ Louver/ Rolling shutter							

FIELD QUALITY PLAN (FQP-CIVIL) FOR 100 MW_p SOLAR PV PROJECT - GSECL RAGHANESDA PHASE-II

Sl. No	Activity and operation	Characteristics / instruments		Class of Check	Type of Check	Quantum Of check	Reference Document	Remarks
1	2	3			4	5	6	7
i		Material fabrication and fixtures	As agreed / required	B	BHEL/GSECL Approved source and review of DC/Invoice /Review of MTC	Each lot of delivery	IS: 1038 / IS:1361, IS: 7452 and Tech Specs and Const. Drawings,SR	Review of Manufacturer/Fabricator shop inspection report/Invoice/DC
ii		Finishing and acceptance	As agreed / required	B	Visual / physical	Random	IS: 1038 / IS:1361, IS: 7452 and Tech Specs and Const. Drawings,SR	Review of Manufacturer/Fabricator shop inspection report/Invoice/DC
7.4 Glass and glazing								
i	Clear float glass, tinted glass, curtain glass, hermetically sealed glass	Material	As agreed / required	A	BHEL/GSECL Approved source and review of Dealer/Suppliers Invoice /DC / Review of MTC	For each lot received at site	IS:1081, IS: 3548, Tech Specs and Const. Drawings,SR	
ii		Installation finishing and acceptance	As agreed / required	A	Visual/ Physical	Random	Tech Specs and Const. Drawings,SR	Leak proof installation with neoprene gasket
7.5 False Ceiling								
i		600*600*12mm gypsum tile false ceiling with AL grid	As agreed / required	B	BHEL/GSECL Approved source and review of Dealer/Suppliers Invoice /DC / Review of MTC	Physical inspection	Tech Specs and Const. Drawings,SR	
ii		Installation finishing and acceptance	As agreed / required	B	Visual / physical	Random	Tech Specs and Const. Drawings,SR	
8 Water Storage Tanks								
i	Material	Over head / loft type	As agreed / required	A	BHEL/GSECL Approved source /Review of MTC	Each lot of delivery as per Specifications	Tech Specs and Const. Drawings,SR	
ii		Acceptance and leakage	As agreed / required	A	Acceptance	Random	Tech Specs and Const. Drawings,SR	
9.0 ROAD WORKS								
9.1 Construction of Sub-Grade and earthen/hard soulders								
i		Coordinate and center line marking and checking	As agreed / required	A	Visual/ Physical dimensions report	Random	Tech Specs and Const. Drawings	
i		Standard proctor Test	As per IS: 2720	A	Physical	Once for each type and source of fill materials	As per Tech Specs and Const. Drawings,Section 900 of MORTH specification 5th Rev., IS 2720 (Pt.VII)	
ii		Moisture content of fill before compaction	As per IS: 2720	B	Physical	Once for each type and source of fill materials	As per Tech Specs and Const. Drawings, Section 900 of MORTH specification 5th Rev., IS 2720 (Pt.II)	
iii		Dry density by core cutter method	As per IS: 2720	A	Physical	Once in every 1000 SQM area of subgrade & 1000 SQM area of embankment for each compacted layer.	As per Tech Specs and Const. Drawings, Section 900 of MORTH specification 5th Rev., IS 2720 (Pt. XXIX)	
9.2 Water Bound Macadam (Non-Bituminous) for base course and sub-base course								

FIELD QUALITY PLAN (FQP-CIVIL) FOR 100 MW_p SOLAR PV PROJECT - GSECL RAGHANESDA PHASE-II

Sl. No	Activity and operation	Characteristics / instruments		Class of Check	Type of Check	Quantum Of check	Reference Document	Remarks
1	2	3			4	5	6	7
i		Aggregate Impact value	Aggregate Impact value Test Apparatus	A	Physical	One test of each source and whenever there is change in quality of aggregate	As per Tech Specs and Const. Drawings, Section 900 of MORTH specification 5th Rev.	
ii		Grading	Set of IS Sieves	B	Physical	One test of each source and whenever there is change in quality of aggregate	As per Tech Specs and Const. Drawings, Section 900 of MORTH specification 5th Rev.	
iii		Flakiness index and elongation index	Flakiness test gauge	B	Physical	One test of each source and whenever there is change in quality of aggregate	As per Tech Specs and Const. Drawings, Section 900 of MORTH specification,	
iv		Atterberg Limits of binding material	Atterberg limits determination	A	Physical	One test of each source and whenever there is change in quality of aggregate	As per Tech Specs and Const. Drawings, Section 900 of MORTH specification 5th Rev.	
9.3 Bituminous Surfacing - Open graded premix carpet and Seal coat								
i		Quality of binder	Penetrometre with St. needle	A	Physical / Review of MTC	No. of samples per Lot & tests as per IS:73, IS:217, IS:8887 as applicable	IS 73, Tech Specs and Const. Drawings, Section 900 of MORTH specification 5th Rev.	
ii		Aggregate Impact Value / Los angeles abrasion value	Aggregate Impact Value Test apparatus	B	Physical	One test of each source and whenever there is change in quality of aggregate	As per Tech Specs and Const. Drawings, Section 900 of MORTH specification 5th Rev.	
iii		Flakiness Index and elongation index of aggregates	Flakiness test gauge	B	Physical	One test of each source and whenever there is change in quality of aggregate	As per Tech Specs and Const. Drawings, Section 900 of MORTH specification 5th Rev.	
iv		Stripping value of aggregate (Immersion tray test)	As required	B	Physical	One test of each source and whenever there is change in quality of aggregate	As per Tech Specs and Const. Drawings, Section 900 of MORTH specification 5th Rev.	
v		Water absorption test	As required	A	Physical	One test of each source and whenever there is change in quality of aggregate	As per Tech Specs and Const. Drawings, Section 900 of MORTH specification 5th Rev.	
vi		Water sensitivity of mix	As required	A	Physical	One test of each source and whenever there is change in quality of aggregate	As per Tech Specs and Const. Drawings, Section 900 of MORTH specification 5th Rev.	
vii		Grading of aggregates	Set of Sieves	B	Physical	One test of each source and whenever there is change in quality of aggregate	As per Tech Specs and Const. Drawings, Section 900 of MORTH specification 5th Rev.	
viii		Soundness (Magnesium and Sodium Sulphate)	As required as per IS:2386	A	Physical	One test of each source and whenever there is change in quality of aggregate	As per Tech Specs and Const. Drawings, Section 900 of MORTH specification 5th Rev.	
ix		Polished stone value	As required as per BS:812(Part 114)	B	Physical	One test of each source and whenever there is change in quality of aggregate	As per Tech Specs and Const. Drawings, Section 900 of MORTH specification 5th Rev.	

FIELD QUALITY PLAN (FQP-CIVIL) FOR 100 MW_p SOLAR PV PROJECT - GSECL RAGHANESDA PHASE-II

Sl. No	Activity and operation	Characteristics / instruments		Class of Check	Type of Check	Quantum Of check	Reference Document	Remarks
1	2	3			4	5	6	7
x		Temperature of binder at application	Thermometer	A	Physical	At regular close intervals	As per Tech Specs and Const. Drawings, Section 900 of MORTH specification 5th Rev.	
xi		Bitumen content	Bitumen extractor	A	Physical / Review of MTC	one tests per day per plant	As per Tech Specs and Const. Drawings, Section 900 of MORTH specification 5th Rev.	
xii		Percentage of fractured faces	Bitumen extractor	A	Physical	When gravel is used one test per 100 cum of aggregates	As per Tech Specs and Const. Drawings, Section 900 of MORTH specification 5th Rev.	
9.4 Tack Coat/ Prime coat/ fog coat								
i		Quality of binder	Penetrometre with Standard needle	A	Physical / Review of MTC	One test of each source	IS 73, Tech Specs and Const. Drawings, Section 900 of MORTH specification 5th Rev.	
ii		Temperature of binder at application	Thermometer	B	Physical	At regular close intervals	As per Tech Specs and Const. Drawings, Section 900 of MORTH specification 5th Rev.	
iii		Rate of spread of binder	As required	B	Physical	three tests per day	As per Tech Specs and Const. Drawings, Section 900 of MORTH specification 5th Rev.	
9.50	Hot mix plant	Quality	As required	B	Physical	Review and approval of hot mix design report from supplier, Review and approval of periodic tests from supplier	As per Tech Specs and Const. Drawings,	
10.00 MMS PILING WORKS								
i		Coordinates of Pile	Marking with Total station	B	Physical	Each Pile	Tech Specs or Const. Drawings	RANDOM CHECK BY GSECL FQA ENGINEERS
ii		Drilling of Piles	DTH/Auger	B	Physical	Each Pile	Tech Specs or Const. Drawings	
iii	Dimensions of Pile	Depth and Dia	Measuring Tape	B	Physical	Each Pile	Tech Specs or Const. Drawings	
iv		Verticality	Spirit Level	B	Physical	Each Pile	Tech Specs or Const. Drawings	
v	Anchor Bolt	Length & Dia	Measuring Tape	B	Physical / Review of MTC	Each Pile	Tech Specs or Const. Drawings	
vi		Projection above first stage concrete	As required	B	Physical	Each Pile	Tech Specs or Const. Drawings	
vii	Pile cap	Height & Dia	Measuring Tape	B	Physical	Each Pile	Tech Specs or Const. Drawings	
viii		Verticality and alignment	Spirit Level	B	Physical	Each Pile	Tech Specs or Const. Drawings	
ix		acceptance of pile and pile cap	Visually	B	Physical	Each Pile	Tech Specs or Const. Drawings	
11.0 FURNITURE ITEMS								
i		Materials	As required	B	Physical / Review of MTC	Each batch of delivery	Tech Specs and Const. Drawings	
		Acceptance of the installation	As required	B	Physical / measurements	Each installation	Tech Specs and Const. Drawings	
12.0	Water Tank(Concrete underground)							

FIELD QUALITY PLAN (FQP-CIVIL) FOR 100 MW_p SOLAR PV PROJECT - GSECL RAGHANESDA PHASE-II

Sl. No	Activity and operation	Characteristics / instruments	Class of Check	Type of Check	Quantum Of check	Reference Document	Remarks	
1	2	3		4	5	6	7	
i		Acceptance of the installation	As required	A	Water tightness test /Physical / measurements	Each installation	Tech Specs and Const. Drawings	
<p>Legend to be used: Class # : A = Critical, B=Major, C=Minor;</p>								
Manufac turer/ Sub-supplier	Main-supplier	<p>Categorization Witnessing & Accepting Category 'A' GSECL FQA Engineer in association with BHEL and Sub-contractor Engineer, Category 'B' BHEL and Sub-contractor Engineer, Category 'C' Sub-contractor Engineer; MTC = Manufacturer's Test Certificate: SR = Site Register; TC =Test certificate from lab,external agency.</p>						
Signature		This document shall be read in conjunction with BHEL/GSECL Tech. Specifications, BOQ, Drawings				REVIEWED BY	APPROVED BY	APPROVAL SEAL

Guidelines for Reverse Auction – 2021

Doc. No. AA:SSP:RA:05
Dated: 08.03.2021

1.0 Scope

This document describes the guidelines to be followed by BHEL for conducting Reverse Auction (RA) for procurement of material/ works/ services. The RA shall follow the philosophy of English Reverse (No ties).

English Reverse (No ties) is a type of auction where the starting price and bid decrement are announced before start of online reverse auction. The interested bidders can thereupon start bidding in an iterative process wherein the lowest bidder at any given moment can be displaced by an even lower bid of a competing bidder, within a given time frame. The bidding is with reference to the current lowest bid in the reverse auction. All bidders will see the current lowest quoted price and their rank. The term 'No ties' is used since more than one bidder cannot give an identical price, at a given instant, during the reverse auction. In other words, there shall never be a tie in the bids.

3.0 Upfront declaration in NIT

Decision to go for RA would be taken before floating of the tender. In case it is decided to go for RA, same shall be declared upfront in NIT by inserting the following **clause**:

"BHEL shall be resorting to Reverse Auction (RA) (Guidelines as available on www.bhel.com) for this tender. RA shall be conducted among the techno-commercially qualified bidders.

Price bids of all techno-commercially qualified bidders shall be opened and same shall be considered for RA. In case any bidder(s) do(es) not participate in online Reverse Auction, their sealed envelope price bid along with applicable loading, if any, shall be considered for ranking."

6.0 Business rules for RA

Model Annexure-I is attached.

7.0 Role of Service Provider

- Acknowledge the receipt of mandate from BHEL.
- Contact the bidders, provide business rules and train them, as required.
- Get the process compliance form signed by all the participating bidders before RA event.

Guidelines for Reverse Auction – 2021

Doc. No. AA:SSP:RA:05
Dated: 08.03.2021

- Conduct the event as per the contract and business rules.
- Submit the Login Reports, Results, History sheet and authorized final bid from the bidders.
- To obtain price breakup from successful bidder and submit the same to BHEL.

10.0 Reverse Auction Process

10.1 Reverse Auction will be conducted if two or more bidders are techno-commercially qualified. In case of two or three qualified bidders, there shall be no elimination of H1 bidder (whose quote is highest in sealed envelope price bid). In case of four qualified bidders, the H1 bidder shall be eliminated whereas in case of five qualified bidders, H1 & H2 bidders shall be eliminated. However, in case of six or more qualified bidders are available, RA would be conducted amongst first 50% of the bidders arranged in the order of prices from lowest to highest. Number of bidders eligible for participating in RA would be rounded off to next higher integer value if number of qualified bidders is odd (e.g. if 7 bids are qualified, then RA will be conducted amongst lowest four bidders). However, there will be no elimination of qualified bidders who are MSE or qualifying under PPP-MII, Order 2017, irrespective of the number of bidders qualifying techno-commercially.

In case of multiple H1 bidders, all H1 bidders (excluding MSEs and bidders qualifying under PPP-MII, Order 2017) shall be removed provided minimum two bidders remain in fray, else no H1 removal.

10.2 During RA, all bidders will see their rank and current L1 price on the screen. Once the RA is done, the ranking status would be based on the last quoted price of the bidder(s) irrespective of the quote received in RA or sealed envelope price bid.

10.3 No bidder shall be allowed to lower its bid below the current L1 by more than 5 decrements at one go.

11.0 Processing of case after RA

11.2 In case of splitting requirement, bidders who were removed from participation in RA may also be considered for counter offer if the pre-stated (NIT) numbers of suppliers do not accept the counter offer.

Guidelines for Reverse Auction – 2021

Doc. No. AA:SSP:RA:05
Dated: 08.03.2021

13.0 Others

- 13.2 In case of enquiry through e-Procurement, the sealed electronic price bid (e-bid) is to be treated as sealed envelope price bid.
- 13.3 BHEL will inform bidders the details of service provider who will provide business rules, all necessary training and assistance before commencement of online bidding.
- 13.4 Bidders will be advised to read the 'Business Rules' indicating details of RA event carefully, before reverse auction event.

---XXX---

ABRIDGED VERSION

Guidelines for Reverse Auction – 2021

Doc. No. AA:SSP:RA:05

Dated: 08.03.2021

Business Rules for Reverse Auction

Annexure – I

This has reference to tender no **{tender number....date...}**. BHEL shall finalise the Rates for the supply of *{item name}* through Reverse Auction mode. BHEL has made arrangement with M/s. *{Service provider}*, who shall be BHEL's authorized service provider for the same. Bidders should go through the instructions given below and submit acceptance of the same.

The technical & commercial terms are as per (a) BHEL Tender Enq. No. {...} dated {...}, (b) Bidders' technical & commercial bid (in case of two part bid) and (c) subsequent correspondences between BHEL and the bidders, if any.

1. Procedure of Reverse Auctioning

- i. Price bids of all techno-commercially qualified bidders shall be opened.
- ii. **Reverse Auction:** The 'bid decrement' will be decided by BHEL.
- iv. Bidders by offering a minimum bid decrement or the multiples thereof can displace a standing lowest bid and become "L1" and this continues as an iterative process. However, no bidder shall be allowed to lower its bid below the current L1 by more than 5 decrements at one go.
- v. After the completion of the reverse auction, the Closing Price shall be available for further processing.
- vi. Wherever the evaluation is done on total cost basis, after Reverse Auction, prices of individual line items shall be reduced on pro-rata basis.

2. Schedule for reverse auction: The Reverse Auction is tentatively scheduled on *{date}*: *{start time}*: *{Close Time}*: *}*.

3. Auction extension time: If a bidder places a bid in the last {...} minutes of closing of the Reverse Auction and if that bid gets accepted, then the auction's duration shall get extended automatically for another {...} minutes, for the entire auction (i.e. for all the items in the auction), from the time that bid comes in. Please note that the auto-extension will take place only if a bid comes in those last {...} minutes and if that bid gets accepted as the lowest bid. If the bid does not get accepted as the lowest bid, the auto-extension will not take place even if that bid might have come in the last {...}

Guidelines for Reverse Auction – 2021

Doc. No. AA:SSP:RA:05

Dated: 08.03.2021

Business Rules for Reverse Auction

Annexure – I

minutes. In case, there is no bid in the last {...} minutes of closing of Reverse Auction, the auction shall get closed automatically without any extension. However, bidders are advised not to wait till the last minute or last few seconds to enter their bid during the auto-extension period to avoid complications related with internet connectivity, network problems, system crash down, power failure, etc.

The above process will continue till completion of Reverse Auction.

Complaints/ Grievances, if any, regarding denial of service or any related issue should be given in writing thru e-mail/ fax to M/s. {Service provider} with a copy to BHEL within 15 minutes prior to initial closing time of Reverse Auction.

4. **Bid price:** The Bidder has to quote the {...} Price inclusive of Packing & Forwarding charges, all the routine & type tests as per tender scope, taxes, duties, freight and insurance as specified in tender document, including loading (if indicated by BHEL due to deviations in technical/ commercial terms) for the Items specified. Details are as shown in Excel Sheet for calculation of total cost to BHEL (To be specified by Unit as per NIT conditions).
5. **Bidding currency and unit of measurement:** Bidding will be conducted in *Indian Rupees per Unit* of the material as per the specifications {...}

In case of foreign currency bids, exchange rate (TT selling rate of State Bank of India) as on scheduled date of tender opening (Part-I bid) shall be considered for conversion in Indian Rupees. If the relevant day happens to be a Bank holiday, then the forex rate as on the previous bank (SBI) working day shall be taken.
6. **Validity of bids:** Price shall be valid for {... days} from the date of reverse auction. These shall not be subjected to any change whatsoever.
7. **Lowest bid of a bidder:** In case the bidder submits more than one bid, the lowest bid at the end of Reverse Auction will be considered as the bidder's final offer to execute the work.
8. Unique user IDs shall be used by bidders during bidding process. All bids

Guidelines for Reverse Auction – 2021

Doc. No. AA:SSP:RA:05
Dated: 08.03.2021

Business Rules for Reverse Auction

Annexure – I

made from the Login ID given to the bidders will be deemed to have been made by the bidders/ bidders' company.

9. **Post auction procedure:** BHEL will proceed with the Lowest Bid in the Reverse Auction for further processing.
11. Reverse auction shall be conducted by BHEL (through M/s {Service Provider}), on pre-specified date, while the bidders shall be quoting from their own offices/ place of their choice. Internet connectivity shall have to be ensured by bidders themselves.

During the RA process if a bidder is not able to bid and requests for extension of time by FAX/ email/ phone then time extension of additional 15 minutes will be given by the service provider provided such requests come before 5 minutes of auction closing time. However, only one such request per bidder can be entertained.

In order to ward-off contingent situation of connectivity failure bidders are requested to make all the necessary arrangements/ alternatives whatever required so that they are able to circumvent such situation and still be able to participate in the reverse auction successfully. Failure of power or loss of connectivity at the premises of bidders during the Reverse auction cannot be the cause for not participating in the reverse auction. On account of this, the time for the auction cannot be extended and neither BHEL nor M/s. {Service provider} is responsible for such eventualities.

12. Proxy bids: Proxy bidding feature is a pro-bidder feature to safe guard the bidder's interest of any internet failure or to avoid last minute rush. The proxy feature allows bidders to place an automated bid in the system directly in an auction and bid without having to enter a new amount each time a competing bidder submits a new offer. The bid amount that a bidder enters is the minimum that the bidder is willing to offer. Here the software bids on behalf of the bidder. This obviates the need for the bidder participating in the bidding process until the proxy bid amount is decrementally reached by other bidders. When proxy bid amount is reached, the bidder (who has submitted the proxy bid) has an option to start participating in the bidding process.

The proxy amount is the minimum amount that the bidder is willing to offer.

Guidelines for Reverse Auction – 2021

Doc. No. AA:SSP:RA:05

Dated: 08.03.2021

Business Rules for Reverse Auction

Annexure – I

During the course of bidding, the bidder cannot delete or change the amount of a proxy bid.

Bids are submitted in decrements (decreasing bid amounts). The application automates proxy bidding by processing proxy bids automatically, according to the decrement that the auction originator originally established when creating the auction, submitting offers to the next bid decrement each time a competing bidder bids, regardless of the fact whether the competing bids are submitted as proxy or standard bids. However, it may please be noted that if a manual bid and proxy bid are submitted at the same instant manual bid will be recognized as the L1 at that instant.

In case of more than one proxy bid, the system shall bid till it crosses the threshold value of 'each lowest proxy bid' and thereafter allow the competition to decide the final L1 price.

Proxy bids are fed into the system directly by the respective bidders. As such this information is privy only to the respective bidder(s).

13. Bidders are advised to get fully trained and clear all their doubts such as refreshing of Screen, quantity being auctioned, tender value being auctioned etc from M/s {Service provider}.
14. M/s. {Service provider}, shall arrange to demonstrate/ train the bidder or bidder's nominated person(s), without any cost to bidders. M/s. {Service provider}, shall also explain the bidders, all the business rules related to the Reverse Auction. Bidders are required to submit their acceptance to the terms/ conditions/ modalities before participating in the Reverse Auction in the process compliance form as enclosed. Without this, the bidder will not be eligible to participate in the event.
15. Successful bidder shall be required to submit the final prices (L1) in prescribed format (Annexure – VI) for price breakup, quoted during the Reverse Auction, duly signed and stamped as token of acceptance without any new condition (other than those already agreed to before start of auction), after the completion of auction to M/s. {Service provider} besides BHEL within two working days of Auction without fail.
16. Any variation between the final bid value and that in the confirmatory

Guidelines for Reverse Auction – 2021

Doc. No. AA:SSP:RA:05
Dated: 08.03.2021

Business Rules for Reverse Auction

Annexure – I

signed price breakup document will be considered as tampering the tender process and will invite action by BHEL as per extant guidelines for suspension of business dealings (as available on www.bhel.com).

17. Bidders' bid will be taken as an offer to execute the work/ supplies the item as per enquiry no. {...} dt. {...}. Bids once made by the bidder, cannot be cancelled/ withdrawn and bidder shall be bound to execute the work as mentioned above at bidder's final bid price. Should bidder back out and not execute the contract as per the rates quoted, BHEL shall take action as per extant guidelines for suspension of business dealings (as available on www.bhel.com).
18. Bidders shall be able to view the following on their screen along with the necessary fields during Reverse Auction:
 - a. Leading (Running Lowest) Bid in the Auction (only total price of package)
 - b. Bid Placed by the bidder
 - c. Start Price
 - d. Decrement value
 - e. Rank of their own bid during bidding as well as at the close of auction.
19. BHEL's decision on award of contract shall be final and binding on all the Bidders.
20. BHEL reserves the right to extend, reschedule or cancel the Reverse Auction process at any time, before ordering, without assigning any reason, with intimation to bidders.
21. BHEL shall not have any liability to bidders for any interruption or delay in access to the site irrespective of the cause. In such cases, the decision of BHEL shall be binding on the bidders.
22. Other terms and conditions shall be as per bidder's techno-commercial offers and other correspondences, if any, till date.
23. If there is any clash between this business document and the FAQ available, if any, in the website of M/s. {*Service provider*}, the terms & conditions given in this business document will supersede the information contained in the FAQs. Any changes made by BHEL/ service provider (due to unforeseen

Guidelines for Reverse Auction – 2021

Doc. No. AA:SSP:RA:05

Dated: 08.03.2021

Business Rules for Reverse Auction

Annexure – I

contingencies) after the first posting shall be deemed to have been accepted if the bidder continues to access the portal after that time.

24. Bidder shall not divulge either his Bids or any other exclusive details of BHEL to any other party. If the Bidder or any of his representatives are found to be involved in Price manipulation/ cartel formation of any kind, directly or indirectly by communicating with other bidders, action as per extant BHEL guidelines for suspension of business dealings (as available on www.bhel.com), shall be initiated by BHEL.

ABRIDGED VERSION

INTEGRITY PACT

Between

Bharat Heavy Electricals Ltd. (BHEL), a company registered under the Companies Act 1956 and having its registered office at “BHEL House”, Siri Fort, New Delhi – 110049 (India) hereinafter referred to as “The Principal”, which expression unless repugnant to the context or meaning hereof shall include its successors or assigns of the ONE PART

and

_____, (description of the party along with address), hereinafter referred to as “The Bidder/ Contractor” which expression unless repugnant to the context or meaning hereof shall include its successors or assigns of the OTHER PART

Preamble

The Principal intends to award, under laid-down organizational procedures, contract/s for

_____. The Principal values full compliance with all relevant laws of the land, rules and regulations, and the principles of economic use of resources, and of fairness and transparency in its relations with its Bidder(s)/ Contractor(s).

In order to achieve these goals, the Principal will appoint Independent External Monitor(s), who will monitor the tender process and the execution of the contract for compliance with the principles mentioned above.

Section 1 – Commitments of the Principal

- 1.1 The Principal commits itself to take all measures necessary to prevent corruption and to observe the following principles:-
 - 1.1.1 No employee of the Principal, personally or through family members, will in connection with the tender for, or the execution of a contract, demand, take a promise for or accept, for self or third person, any material or immaterial benefit which the person is not legally entitled to.
 - 1.1.2 The Principal will, during the tender process treat all Bidder(s) with equity and reason. The Principal will in particular, before and during the tender process, provide to all Bidder(s) the same information and will not provide to any Bidder(s) confidential / additional information through which the Bidder(s) could obtain an advantage in relation to the tender process or the contract execution.
 - 1.1.3 The Principal will exclude from the process all known prejudiced persons.
- 1.2 If the Principal obtains information on the conduct of any of its employees which is a penal offence under the Indian Penal Code 1860 and Prevention of Corruption Act 1988 or any other statutory penal enactment, or if there be a substantive suspicion in this regard, the Principal will inform its Vigilance Office and in addition can initiate disciplinary actions.

Section 2 – Commitments of the Bidder(s)/ Contractor(s)

- 2.1 The Bidder(s)/ Contractor(s) commit himself to take all measures necessary to prevent corruption. He commits himself to observe the following principles during his participation in the tender process and during the contract execution.
 - 2.1.1 The Bidder(s)/ Contractor(s) will not, directly or through any other person or firm, offer, promise or give to the Principal or to any of the Principal's employees involved in the tender process or the execution of the contract or to any third person any material, immaterial or any other benefit which he / she is not legally entitled to, in

order to obtain in exchange any advantage of any kind whatsoever during the tender process or during the execution of the contract.

2.1.2 The Bidder(s)/ Contractor(s) will not enter with other Bidder(s) into any illegal or undisclosed agreement or understanding, whether formal or informal. This applies in particular to prices, specifications, certifications, subsidiary contracts, submission or non-submission of bids or any other actions to restrict competitiveness or to introduce cartelization in the bidding process.

2.1.3 The Bidder(s)/ Contractor(s) will not commit any penal offence under the relevant IPC/ PC Act; further the Bidder(s)/ Contractor(s) will not use improperly, for purposes of competition or personal gain, or pass on to others, any information or document provided by the Principal as part of the business relationship, regarding plans, technical proposals and business details, including information contained or transmitted electronically.

2.1.4 The Bidder(s)/ Contractor(s) will, when presenting his bid, disclose any and all payments he has made, and is committed to or intends to make to agents, brokers or any other intermediaries in connection with the award of the contract.

2.2 The Bidder(s)/ Contractor(s) will not instigate third persons to commit offences outlined above or be an accessory to such offences.

Section 3 – Disqualification from tender process and exclusion from future contracts

If the Bidder(s)/ Contractor(s), before award or during execution has committed a transgression through a violation of Section 2 above, or acts in any other manner such as to put his reliability or credibility in question, the Principal is entitled to disqualify the Bidders(s)/ Contractor(s) from the tender process or take action as per the separate “Guidelines for Suspension of Business Dealings with Suppliers/ Contractors” framed by the Principal.

Section 4 – Compensation for Damages

- 4.1 If the Principal has disqualified the Bidder(s) from the tender process prior to the award according to Section 3, the Principal is entitled to demand and recover the damages equivalent to Earnest Money Deposit/ Bid Security.
- 4.2 If the Principal has terminated the contract according to Section 3, or if the Principal is entitled to terminate the contract according to section 3, the Principal shall be entitled to demand and recover from the Contractor liquidated damages equivalent to 5% of the contract value or the amount equivalent to Security Deposit/Performance Bank Guarantee, whichever is higher.

Section 5 – Previous Transgression

- 5.1 The Bidder declares that no previous transgressions occurred in the last 3 years with any other company in any country conforming to the anti-corruption approach or with any other Public Sector Enterprise in India that could justify his exclusion from the tender process.
- 5.2 If the Bidder makes incorrect statement on this subject, he can be disqualified from the tender process or the contract, if already awarded, can be terminated for such reason.

Section 6 – Equal treatment of all Bidders/ Contractors/ Sub-contractors

- 6.1 The Bidder(s)/ Contractor(s) undertake(s) to demand from his sub-contractors a commitment consistent with this Integrity Pact. This commitment shall be taken only from those sub-contractors whose contract value is more than 20% of Bidder's/ Contractor's contract value with the Principal.
- 6.2 The Principal will enter into agreements with identical conditions as this one with all Bidders and Contractors.
- 6.3 The Principal will disqualify from the tender process all bidders who do not sign this pact or violate its provisions.

Section 7 – Criminal Charges against violating Bidders/ Contractors /Sub-contractors

If the Principal obtains knowledge of conduct of a Bidder, Contractor or Subcontractor, or of an employee or a representative or an associate of a Bidder, Contractor or Subcontractor which constitutes corruption, or if the Principal has substantive suspicion in this regard, the Principal will inform the Vigilance Office.

Section 8 –Independent External Monitor(s)

- 8.1 The Principal appoints competent and credible Independent External Monitor for this Pact. The task of the Monitor is to review independently and objectively, whether and to what extent the parties comply with the obligations under this agreement.
- 8.2 The Monitor is not subject to instructions by the representatives of the parties and performs his functions neutrally and independently. He reports to the CMD, BHEL.
- 8.3 The Bidder(s)/ Contractor(s) accepts that the Monitor has the right to access without restriction to all contract documentation of the Principal including that provided by the Bidder(s)/ Contractor(s). The Bidder(s)/ Contractor(s) will grant the monitor, upon his request and demonstration of a valid interest, unrestricted and unconditional access to his contract documentation. The same is applicable to Sub-contractor(s). The Monitor is under contractual obligation to treat the information and documents of the Bidder(s)/ Contractor(s) / Sub-contractor(s) with confidentiality.
- 8.4 The Principal will provide to the Monitor sufficient information about all meetings among the parties related to the contract provided such meetings could have an impact on the contractual relations between the Principal and the Contractor. The parties offer to the Monitor the option to participate in such meetings.
- 8.5 As soon as the Monitor notices, or believes to notice, a violation of this agreement, he will so inform the Management of the Principal and request the Management to discontinue or

take corrective action, or heal the situation, or to take other relevant action. The Monitor can in this regard submit non-binding recommendations. Beyond this, the Monitor has no right to demand from the parties that they act in a specific manner, refrain from action or tolerate action.

8.6 The Monitor will submit a written report to the CMD, BHEL within 8 to 10 weeks from the date of reference or intimation to him by the Principal and, should the occasion arise, submit proposals for correcting problematic situations.

8.7 The CMD, BHEL shall decide the compensation to be paid to the Monitor and its terms and conditions.

8.8 If the Monitor has reported to the CMD, BHEL, a substantiated suspicion of an offence under relevant IPC / PC Act, and the CMD, BHEL has not, within reasonable time, taken visible action to proceed against such offence or reported it to the Vigilance Office, the Monitor may also transmit this information directly to the Central Vigilance Commissioner, Government of India.

8.9 The number of Independent External Monitor(s) shall be decided by the CMD, BHEL.

8.10 The word 'Monitor' would include both singular and plural.

Section 9 – Pact Duration

9.1 This Pact begins when both parties have legally signed it. It expires for the Contractor 12 months after the last payment under the respective contract and for all other Bidders 6 months after the contract has been awarded.

9.2 If any claim is made / lodged during this time, the same shall be binding and continue to be valid despite the lapse of this pact as specified as above, unless it is discharged/ determined by the CMD, BHEL.

Section 10 – Other Provisions

- 10.1 This agreement is subject to Indian Laws and jurisdiction shall be registered office of the Principal, i.e. New Delhi.
- 10.2 Changes and supplements as well as termination notices need to be made in writing. Side agreements have not been made.
- 10.3 If the Contractor is a partnership or a consortium, this agreement must be signed by all partners or consortium members.
- 10.4 Should one or several provisions of this agreement turn out to be invalid, the remainder of this agreement remains valid. In this case, the parties will strive to come to an agreement to their original intentions.
- 10.5 Only those bidders/ contractors who have entered into this agreement with the Principal would be competent to participate in the bidding. In other words, entering into this agreement would be a preliminary qualification.

For & On behalf of the Principal
(Office Seal)

For & On behalf of the Bidder/ Contractor
(Office Seal)

Place-----

Date-----

Witness: _____
(Name & Address) _____

Witness: _____
(Name & Address) _____

INTEGRITY PACT

(a) IP is a tool to ensure that activities and transactions between the Company and its Bidders/Contractors are handled in a fair, transparent and corruption free manner. A panel of Independent External Monitors (IEMs) have been appointed to oversee implementation of IP in BHEL. The IP as enclosed with the tender (total 7 sheets) is to be submitted (duly signed by authorized signatory who signs in the offer) along with techno-commercial bid. Only those bidders who have entered into such an IP with BHEL would be competent to participate in the bidding. In other words, entering into this Pact would be a preliminary qualification.

Details of IEM for this tender is furnished below :

Mr. Arun Chandra Verma, IPS (Retd.)

Mr. Virendra Bahadur Singh IPS (Retd)

(b) Please refer Section-8 of the IP for Role and Responsibilities of IEMs. In case of any complaint arising out of the tendering process, the matter may be referred to the IEM mentioned in the tender. No routine correspondence shall be addressed to the IEM (phone/post/email) regarding the clarifications, time extensions or any other administrative queries, etc. on the tender issued. All such clarification/issues shall be addressed directly to the tender issuing (procurement) department.”

**PROFORMA OF BANK GUARANTEE FOR EARNEST MONEY
(On non-Judicial paper of appropriate value)**

Bank Guarantee No.....
Date.....

To

(Employer's Name and Address)
.....

Dear Sirs,

In accordance with the terms and conditions of Invitation for Bids/Notice Inviting Tender No.....1(Tender Conditions), M/s. having its registered office at2 (hereinafter referred to as the 'Tenderer'), is submitting its bid for the work of.....3 invited by4.(name of the Employer) through its Unit at(

The Tender Conditions provide that the Tenderer shall pay a sum of Rs as Earnest Money Deposit in the form therein mentioned. The form of payment of Earnest Money Deposit includes Bank Guarantee executed by a Scheduled Bank.

In lieu of the stipulations contained in the aforesaid Tender Conditions that an irrevocable and unconditional Bank Guarantee against Earnest Money Deposit for an amount of5 is required to be submitted by the Tenderer as a condition precedent for participation in the said Tender and the Tenderer having approached us for giving the said Guarantee,

we, the[Name & address of the Bank] having our Registered Office at(hereinafter referred to as the Bank) being the Guarantor under this Guarantee, hereby irrevocably and unconditionally undertake to forthwith and immediately pay to the Employer without any demur, merely on your first demand any sum or sums of Rs. 5(in words Rupees.....) without any reservation, protest, and recourse and without the beneficiary needing to prove or demonstrate reasons for its such demand.

Any such demand made on the Bank shall be conclusive as regards the amount due and payable by the Bank under this guarantee. However, our liability under this guarantee shall be restricted to an amount not exceeding Rs. _____.

We undertake to pay to the Employer any money so demanded notwithstanding any dispute or disputes raised by the Vendor/Contractor/Vendors in any suit or proceeding pending before any Court or Tribunal, Arbitrator or any other authority, our liability under this present being absolute and unequivocal.

The payment so made by us under this Guarantee shall be a valid discharge of our liability for payment hereunder and the Tenderer shall have no claim against us for making such payment.

We Bank further agree that the Employer shall have the fullest liberty without our consent and without affecting in any manner our obligations hereunder to vary any of the terms and conditions of the said Tender or to extend the time of submission of from time to time or to postpone for any time or from time to time any of the powers exercisable by the Employer against the said Tenderer and we shall not be relieved from our liability by reason of any such variation, or extension being granted to the said Tenderer or for any forbearance, act or omission on the part of the Employer or any indulgence by the Employer to the said Tenderer or by any such matter or thing whatsoever which under the law relating to sureties would but for this provision have effect of so relieving us.

The Bank also agrees that the Employer at its option shall be entitled to enforce this Guarantee against the Bank as a principal debtor, in the first instance without proceeding against the Tenderer and notwithstanding any security or other guarantee that the Employer may have in relation to the Tenderer's liabilities.

This Guarantee shall be irrevocable and shall remain in force upto and including.....6 and shall be extended from time to time for such period as may be desired by the Employer.

This Guarantee shall not be determined or affected by liquidation or winding up, dissolution or change of constitution or insolvency of the Tenderer but shall in all respects and for all purposes be binding and operative until payment of all money payable to the Employer in terms hereof. However, unless a demand or claim under this Guarantee is made on us in writing on or before the⁷ we shall be discharged from all liabilities under this Guarantee.

We, Bank lastly undertake not to revoke this guarantee during its currency except with the previous consent of the Employer in writing.

Notwithstanding anything to the contrary contained hereinabove:

- a) The liability of the Bank under this Guarantee shall not exceed.....5.....
- b) This Guarantee shall be valid up to6
- c) Unless the Bank is served a written claim or demand on or before _____⁷ all rights under this guarantee shall be forfeited and the Bank shall be relieved and discharged from all liabilities under this guarantee irrespective of whether or not the original bank guarantee is returned to the Bank

We, _____ Bank, have power to issue this Guarantee under law and the undersigned as a duly authorized person has full powers to sign this Guarantee on behalf of the Bank.

For and on behalf of

(Name of the Bank)

Date.....

Place of Issue.....

PRICE BID (GSECL 100MW RAGHANESDA PH-II)

CONSTRUCTION OF ROADS, DRAINS, CULVERT AND 4 Nos OF 2.5 LAKH LITRES CAPACITY UNDERGROUND RCC WATER TANK FOR 100 MWp SOLAR PV PLANT FOR GSECL, RAGHANESDA PHASE-II

Sl.no	DESCRIPTION	UNIT	QTY	ITEM RATE (Excluding GST)	Amount in Rs.
I	ROADS, DRAINS & CULVERT				
1	Earth work in excavation by mechanical means (Hydraulic excavator) / manual means over areas (exceeding 30cm in depth. 1.5m in width as well as 10 sqm on plan) including rolling, compaction MDD 95% , disposal of excavated earth, lead upto 5 km, lift upto 1.5m, disposed earth to be levelled and neatly dressed. All kinds of soil	cum	375.00	149.12	55920.00
2	Earth work in excavation by mechanical means (Hydraulic excavator) / manual means over areas (exceeding 30 cm in depth, 1.5m in width as well as 10 sqm on plan) including disposal of excavated earth, lead upto 5km, lift upto 1.5 m, disposed earth to be levelled and neatly dressed. Ordinary rock	cum	5.00	289.01	1445.00
3	Earth work in excavation by mechanical means (Hydraulic excavator) / manual means over areas (exceeding 30 cm in depth, 1.5m in width as well as 10 sqm on plan) including disposal of excavated earth, lead upto 5km and lift upto 1.5 m, disposed earth to be levelled and neatly dressed. Hard rock (blasting prohibited)	cum	5.00	833.28	4166.00
4	Filling (borrowed approved soil/Excavated soil) in layers not exceeding 20 cm in depth, breaking clods, watering, rolling each layer with power roller of minimum 8 tonnes to achieve 97% or more of standard proctor's MDD and dressing up, in embankments for roads, flood banks, marginal banks, and guide banks etc., Ensuring required CBR value / as instructed by Engineer in charge				
(a)	lead upto 5 km and lift upto 1.5 m (All kinds of soil)	cum	7122.00	551.35	3926715.00
(b)	lead upto 10 km and lift upto 1.5 m (All kinds of soil)	cum	7122.00	613.67	4370558.00
(c)	lead upto 20 km and lift upto 1.5 m (All kinds of soil)	cum	7122.00	717.24	5108183.00
(d)	lead upto 50 km and lift upto 1.5 m (All kinds of soil)	cum	7122.00	974.06	6937255.00
5	Construction of granular subbase by providing close graded material conforming to spec, mixing at OMG, carriage, lead & lift, spreading of uniform thickness motor graded on prepared surface, compacted with vibratory power roller to achieve 97% or more of standard proctor's MDD as per spec & instruction of engineer in charge.	Cum	5707.00	2064.51	11782159.00
6	Supplying and stacking at site. 63 mm to 45 mm size stone aggregate (WBM Gr-II)	cum	3344.00	1259.23	4210865.00
7	Supplying and stacking at site. 53 mm to 22.4 mm size stone aggregate. (WBM Gr-III)	cum	3344.00	1434.80	4797971.00
8	Supplying and stacking at site. Stone screening 11.2 mm nominal size (Type B)	cum	1445.00	1622.37	2344325.00
9	Supplying and stacking at site Binding material.	cum	642.00	662.40	425261.00
10	Laying, spreading and compacting stone aggregate of specified sizes to WBM specifications in uniform thickness, hand picking, rolling with 3 wheeled road / vibratory roller 8-10 tonne capacity in stages to proper grade and camber, applying and brooming requisite type of screening / binding material to fill up interstices of coarse aggregate, watering and compacting to the required density .	cum	5350.00	629.15	3365953.00
11	Providing and applying tack coat using hot straight run bitumen of grade VG - 10, including heating the bitumen, spraying the bitumen with mechanically operated spray unit fitted on bitumen boiler, cleaning and preparing the existing road surface as per specifications : On W.B.M. @ 0.75 Kg / sqm	sqm	35663.00	34.48	1229660.00
12	2 cm premix carpet surfacing with 1.8 cum and 0.90 cum of stone chippings of 13.2 mm size and 11.2 mm size respectively per 100 sqm. and 52 kg. and 56 kg. of hot bitumen per cum of stone chippings of 13.2 mm and 11.2 mm size respectively including a tack coat with hot straight run bitumen including consolidation with road roller of 6 to 9 tonne capacity etc. complete: (tack coat to be paid for separately). With Refinery Modified Bitumen CRMB 55 conforming to IRC: SP: 53-1999. (Laying of Pre-mix carpet shall be done by Paver only.)	sqm	35663.00	151.37	5398308.00

PRICE BID (GSECL 100MW RAGHANESDA PH-II)

CONSTRUCTION OF ROADS, DRAINS, CULVERT AND 4 Nos OF 2.5 LAKH LITRES CAPACITY UNDERGROUND RCC WATER TANK FOR 100 MWp SOLAR PV PLANT FOR GSECL, RAGHANESDA PHASE-II

Sl.no	DESCRIPTION	UNIT	QTY	ITEM RATE (Excluding GST)	Amount in Rs.
13	Providing and applying tack coat using hot straight run bitumen of grade VG - 10 including heating the bitumen, spraying the bitumen with mechanically operated spray unit fitted on bitumen boiler, cleaning and preparing the existing road surface as per specifications : On bituminous surface @ 0.50 Kg / sqm.	sqm	35663.00	27.59	983942.00
14	Providing and laying seal coat (TYPE A) of premixed fine aggregate (passing 2.36 mm and retained on 180 micron sieve) with bitumen using 128 kg of bitumen of grade VG - 10 bitumen per cum of fine aggregate and 0.60 cum of fine aggregate per 100 sqm of road surface including rolling and finishing with road roller all complete.	sqm	35663.00	60.43	2155115.00
15	Conducting laboratory test on soil samples at an NABL accredited laboratory including preparation of soil samples to determine the CBR test and consolidation in report as per specification	Each	18.00	4250.00	76500.00
16	Earth work in excavation by mechanical means (Hydraulic excavator) / manual means in foundation trenches or drains (exceeding 1.5 m in width or 10 sqm on plan), including dressing, ramming, stabilisation of sides and bottoms, lift upto 1.5 m, including getting out the excavated soil and disposal of surplus excavated soil as directed,within a lead of 5km,disposed earth to be levelled and neatly dressed. All kinds of soil	cum	7962.68	206.89	1647398.00
17	Excavation work by mechanical means (Hydraulic excavator)/ manual means in foundation trenches or drains (exceeding 1.5 m in width or 10 sqm on plan), including dressing, ramming, stabilisation of sides and bottoms, lift upto 1.5 m, including getting out the excavated soil and disposal of surplus excavated soil as directed,within a lead of 5km,disposed earth to be levelled and neatly dressed. Ordinary rock	cum	5.00	367.48	1837.00
18	Filling (borrowed approved soil) (excluding rock) in trenches, plinth, sides of foundations etc. in layers not exceeding 20cm in depth, consolidating each deposited layer by ramming and watering, lead up to 1.5km and lift upto 1.5 m.	cum	52.00	180.11	9366.00
19	Providing and laying in position cement concrete of specified grade excluding the cost of centering and shuttering - All work up to plinth level 1:2:4 (1 cement : 2 coarse sand : 4 graded stone aggregate 20 mm nominal size) with smooth finish.	cum	1525.00	5566.65	8489141.00
20	Providing and laying in position cement concrete of specified grade excluding the cost of centering and shuttering - All work up to plinth level 1:4:8 (1 cement : 4 coarse sand : 8 graded stone aggregate 40 mm/20mm nominal size) with smooth finish	cum	541.00	4747.47	2568381.00
21	Providing and laying in position machine batched and machine mixed designmix M-25 grade cement concrete for reinforced cement concrete work, using cement content as per approved design mix, including pumping of concrete to site of laying but excluding the cost of centering, shuttering, finishing and reinforcement, including admixtures in recommended proportions as per IS: 9103 to accelerate, retard setting of concrete, improve workability without impairing strength and durability as per direction of Engineer-in-charge. All works upto plinth level.	cum	10.00	6557.79	65578.00
22	Steel reinforcement for R.C.C. work including straightening, cutting,bending, placing in position and binding all complete upto all level. Thermo-Mechanically Treated bars of grade Fe-415 CRS .	kg	50.00	68.47	3424.00
23	Centering and shuttering including strutting, propping etc. and removal of form for :Foundations, footings , bases of columns, cover slabs etc. for mass concrete	sqm	149.00	233.58	34803.00

PRICE BID (GSECL 100MW RAGHANESDA PH-II)

CONSTRUCTION OF ROADS, DRAINS, CULVERT AND 4 Nos OF 2.5 LAKH LITRES CAPACITY UNDERGROUND RCC WATER TANK FOR 100 MWp SOLAR PV PLANT FOR GSECL, RAGHANESDA PHASE-II

Sl.no	DESCRIPTION	UNIT	QTY	ITEM RATE (Excluding GST)	Amount in Rs.
24	Steel work welded in built up sections/ framed work including cutting, hoisting, fixing in position and applying a priming coat of approved steel primer and Paint using structural steel etc. as required in gratings, frames, guard bar, ladder, railings, brackets, gates and similar works.	kg	50.00	107.42	5371.00
25	Providing and laying Non Pressure NP-3 class (Medium duty) R.C.C. pipes including collars/spigot jointed with stiff mixture of cement mortar in the proportion of 1:2 (1 cement : 2 fine sand) including testing of joints etc. complete : 450 mm dia. R.C.C. pipe	meter	200.00	1905.60	381120.00
26	Providing and laying Non Pressure NP-3 class (Medium duty) R.C.C. pipes including collars/spigot jointed with stiff mixture of cement mortar in the proportion of 1:2 (1 cement : 2 fine sand) including testing of joints etc. complete :600 mm dia. R.C.C. pipe	meter	5.00	2447.33	12237.00
27	Brick work with common burnt clay F.P.S. (non modular) bricks of class designation 7.5 in foundation and plinth in Cement mortar 1:4 (1 cement : 4 coarse sand)	Cum	17.30	5228.53	90454.00
28	Finishing with 12mm thick cement plaster 1:4 (1 cement: 4 fine sand)	Sqm	79.20	218.82	17331.00
29	Finishing walls with water proofing cement paint of required shade on New work (Two or more coats applied @ 3.84 kg/10 sqm)	Sqm	79.20	74.83	5927.00
30	Random rubble masonry with hard stone in foundation and plinth including levelling up with cement concrete 1:6:12 (1 cement : 6 coarse sand : 12 graded stone aggregate 20 mm nominal size) upto plinth level with Cement mortar 1:6 (1	cum	84.30	5019.06	423127.00
TOTAL AMOUNT OF WORKS (I) (Rs)					70,929,796.00
II	4 Nos. OF 2.5 LAKH LITRE CAPACITY UNDERGROUND RCC WATER TANK	UNIT	QTY	ITEM RATE (Excluding GST)	Amount in Rs.
1	Earth work in excavation by mechanical means (Hydraulic excavator) /manual means over areas (exceeding 30cm in depth. 1.5 m in width as well as 10 sqm on plan) as per required level/camber/gradient including, rolling and compacting the cut surface to achieve 95% or more of standard proctor's MDD , disposal of excavated earth, lead upto 5Km and lift upto 1.5m, disposed earth to be levelled and neatly dressed. (All kinds of soil)	Cum	2966.00	149.12	442289.92
2	Earth work in excavation by mechanical means (Hydraulic excavator)/ manual means over areas (exceeding 30 cm in depth, 1.5 m in width as well as 10 sqm on plan) including getting out and disposal of excavated earth lead upto 5Km and lift upto 1.5 m, as directed by Engineer-in-charge. Ordinary rock	Cum	5.00	289.01	1445.05
3	Filling available excavated earth (excluding rock) in trenches, plinth, sides of foundations etc. in layers not exceeding 20cm in depth, consolidating each deposited layer by ramming and watering, lead up to 5Km and lift upto 1.5 m.	Cum	2003.30	180.11	360814.36
4	Providing and laying in position cement concrete of specified grade excluding the cost of centering and shuttering - All work up to plinth level : 1:2:4 (1 cement : 2 coarse sand (zone-III) : 4 graded stone aggregate 20 mm nominal size).	Cum	58.28	5566.65	324396.53
5	Providing and laying in position machine batched and machine mixed design mix M-30 grade cement concrete for reinforced cement concrete work for water retaining tanks, using cement content as per approved design mix, including pumping of concrete to site of laying but excluding the cost of centering, shuttering, finishing and reinforcement, including plasticiser cum water proofing cement additives in recommended proportions as per IS: 9103 to accelerate, retard setting of concrete, improve workability without impairing strength and durability as per direction of Engineer-in-charge.	Cum	488.29	6946.24	3391779.53

PRICE BID (GSECL 100MW RAGHANESDA PH-II)

CONSTRUCTION OF ROADS, DRAINS, CULVERT AND 4 Nos OF 2.5 LAKH LITRES CAPACITY UNDERGROUND RCC WATER TANK FOR 100 MWp SOLAR PV PLANT FOR GSECL, RAGHANESDA PHASE-II

Sl.no	DESCRIPTION	UNIT	QTY	ITEM RATE (Excluding GST)	Amount in Rs.
6	Providing and mixing integral crystalline admixture for waterproofing treatment to RCC structures like basement raft, retaining walls, reservoir, sewage & water treatment plant, tunnels / subway and bridge deck etc. at the time of transporting of concrete into the drum of the ready-mix truck, using integral crystalline admixture @0.80% (minimum) to the weight of cement content per cubic meter of concrete) or higher as recommended by the manufacturer's specification in reinforced cement concrete at site of work. The material shall meet the requirements as specified in ACI-212-3R-2010 i.e.by reducing permeability of concrete by more than 90%,compared with control concrete as per DIN 1048 and resistant to 16 bar hydrostatic pressure. The crystalline admixture shall be capable of self-healing of cracks up to a width of 0.50mm. The work shall be carried out all complete as per specification and the direction of the Engineer-in-charge. The product performance shall carry guarantee for 10 years against any leakage. water proofing by FOSROC or PIDILITE, SIKA	Kg	1562.53	317.50	496102.64
7	Steel reinforcement for R.C.C. work including straightening, cutting,bending, placing in position and binding all complete upto all level. Thermo-Mechanically Treated bars of grade Fe-415 CRS .	Kg	39063.20	68.47	2674657.30
8	Centering and shuttering including strutting, propping etc. and removal of form for all heights : Foundations, footings, bases of columns, etc. for mass concrete.	sqm	133.20	233.58	31112.86
9	Centering and shuttering including strutting, propping etc. and removal of form for all heights : Walls (any thickness) including attached pilasters, buttresses, plinth and string courses etc.	Sqm	1051.44	499.63	525330.97
10	Centering and shuttering including strutting, propping etc. and removal of form for all heights : Suspended floors, roofs, landings, balconies and access platform.	Sqm	441.80	568.30	251074.94
11	Centering and shuttering including strutting, propping etc. and removal of form for all heights :Lintels, beams, plinth beams, girders, bressumers and cantilevers	Sqm	64.80	452.68	29333.66
12	12 mm cement plaster finished with a floating coat of neat cement of mix : 1:4 (1 cement: 4 fine sand)-Internal Plaster.	Sqm	1356.72	269.17	365188.32
13	12 mm cement plaster of mix : 1:4 (1 cement: 4 fine sand)-External Plaster.	Sqm	582.16	218.82	127388.25
14	Applying one coat of water thinnable cement primer of approved brand and manufacture on wall surface : Water thinnable cement primer.	Sqm	1938.88	49.20	95392.90
15	Finishing walls with water proofing cement paint of required shade : New work (Two or more coats applied @ 3.84 kg/10 sqm)-Make asian ace paint.	Sqm	1938.88	74.83	145086.39
16	Painting with black anti-corrosive bitumastic paint of approved brand and manufacture to give an even shade : Two or more coats on new work Make Berger/Asian paints.	Sqm	582.16	86.96	50624.63
17	Structural steel work riveted, bolted or welded in built up sections,(such as supply & fixing of CI rung work & puddle pipe work req. dia) including cutting, hoisting, fixing in position and applying a priming coat of approved steel primer all complete.	kg	1000.00	83.44	83440.00
18	Painting with synthetic enamel paint of approved brand and manufacture to give an even shade : Two or more coats on new work .Make-Berger/Asian paints.	Sqm	100.00	99.67	9967.00
19	Providing and Placing in position suitable PVC water stops conforming to IS:12200 for construction/ expansion joints between two RCC members and fixed to the reinforcement with binding wire before pouring concrete etc. complete : Serrated with central bulb (225 mm wide, 8-11 mm thick).	meter	250.00	232.22	58055.00
20	Water supply for tank leakage test. Filling the tank with 250000 Litre water and keep it for 24 hrs.	5000L	200.00	738.00	147600.00
21	Hire charges of Pump set of capacity 4000 litres/hour for draining out the water after leakage test.	day	30.00	574.00	17220.00

PRICE BID (GSECL 100MW RAGHANESDA PH-II)

CONSTRUCTION OF ROADS, DRAINS, CULVERT AND 4 Nos OF 2.5 LAKH LITRES CAPACITY UNDERGROUND RCC WATER TANK FOR 100 MWp SOLAR PV PLANT FOR GSECL, RAGHANESDA PHASE-II

Sl.no	DESCRIPTION	UNIT	QTY	ITEM RATE (Excluding GST)	Amount in Rs.
22	Providing and applying of swellable type water stop tape, 19mm x 25mm thick in linear meter (expansive nature) for construction joints treatment of RCC structure, such as raft slab, retaining walls, water storage tank and at the junctions of raft slab with the retaining walls etc.. After cleaning the surface, one coat of required primer for swellable water stop tape shall be applied throughout the length of the joint @3.78 litre per 240 running meter. Over the primed surface swellable type water stop tape shall be placed. The work shall be carried out all complete as per specification and the direction of the engineer-in-charge. The product performance shall carry guaranteed for 10 years against any leakage.	meter	250.00	452.80	113200.00
23	Providing and fixing Chlorinated Polyvinyl Chloride (CPVC) pipes, having thermal stability for hot & cold water supply including all CPVC plain & brass threaded fittings This includes jointing of pipes & fittings with one step CPVC solvent cement, trenching, refilling & testing of joints complete as per direction of Engineer in Charge:				
a	40 mm nominal outer dia Pipes	meter	20.00	440.14	8802.80
b	100 mm nominal inner dia Pipes	meter	20.00	2279.23	45584.60
c	150 mm nominal inner dia Pipes	meter	20.00	4773.92	95478.40
24	Supplying and filling with stone dust as CNS filling material below tank raft, including watering, ramming, consolidating and dressing complete.	cum	555.00	902.00	500610.00
25	Rubble soling 230 mm thick including supply of stones, compaction, filling of voids, preparing surface etc complete in all respect and as per direction of Engineer-in-charge.	Sqm	555.00	598.76	332311.80
TOTAL AMOUNT OF WORKS (II) (Rs)					10,724,288.00
TOTAL AMOUNT OF WORKS (I+II) (Rs)					81,654,084.00
QUOTE PERCENTAGE (%) ABOVE/BELOW (+/-) (OR) AT PAR TO TOTAL AMOUNT					
QUOTED PERCENTAGE (%) IN WORDS ABOVE/BELOW (OR) AT PAR TO TOTAL AMOUNT					
Plus applicable GST					
NOTE:					
1. CONTRACTOR SHOULD QUOTE PERCENTAGE (%) ABOVE/BELOW (OR) AT PAR TO TOTAL AMOUNT					
2. QUOTED PERCENTAGE (%) IS APPLICABLE ON ALL ITEM RATES UNIFORMLY.					