

SUB: Procurement of Grooving Tool

NIT-Notice Inviting Tender

Salient Details of Notice Inviting Tender (NIT)		
Sl. No.	Issue	Description
1.	Item details	As per <u>ANNEXURE-1</u>
2.	Issue of Tender Documents	From BHEL eProcurement website https://eprocurebhel.co.in/nicgep/app (Tender documents will be available for downloading from BHEL e-Procurement website till due date of submission)
3.	Due Date Of Offer Submission	Date: 27.08.2022, Time: 13:45 hrs https://eprocurebhel.co.in/nicgep/app Offer to be submitted in online only through e-procurement Portal. (Bidders are requested to visit website to view corrigendum/ addenda/ amendments/ extension/ modification etc. before submitting offer).
4.	Opening of Tender (Techno-Commercial Bid)	Date: 27.08.2022, Time: 14.00 Hrs Notes: This tender being an e-tender, it shall be opened online only through the E-Procurement Portal. Participating bidders may witness the Opening online only.
5.	Cost of Tender	INR 2000.00 (If hard copy of tender document is required from BHEL)
6.	EMD (Earnest Money Deposit)	Nil
7.	Schedule Of Pre-Bid Discussion	Not Applicable
8.	Last Date of Seeking Clarification	Date: 26.08.2022, Time: 17.00 Hrs Along with soft version also, addressing to undersigned & to others as per contact address given below. Bidders may consider to seek clarifications on the e-tender portal--- https://eprocurebhel.co.in/nicgep/app
9.	Integrity Pact & Details of Independent External Monitor (IEM)	Not Applicable
10.	Make in India	For this procurement, Public procurement (preference to Make in India), Order 2017 dated 15.06.2017, 28.05.2018, 29.05.2019 & 04.06.2020 and subsequent orders issued by the respective nodal ministry shall not be applicable.
11.	Restrictions under rule 144 (xi) of General Financial Rule (GFRs) 2017	All provisions of order no F.No.6/18/2019-PPD of department of Expenditure(DoE) shall be applicable for this tender enquiry (Order copy is available at https://doe.gov.in/procurement-policy-divisions). Accordingly, any bidder from a country which shares a land

		<p>border with India (except the countries to which the GoI has extended lines of credit or in which the GoI is engaged in development projects for which list is available at https://www.mea.gov.in/) will be eligible to bid in this tender only if the bidder is registered with the Competent Authority as specified in Annex I of the said Order of DoE.</p> <p>Updated list of the countries to which lines of credit have been extended or in which development projects are undertaken are available on the Ministry of External affairs website (https://www.mea.gov.in/).</p> <p>For the purpose of this order, definition of Bidder from a country which shares a land border with India shall be same as defined in the Annex III of the said order.</p> <p>Registration with the competent authority as stipulated in the said order is responsibility of bidder.</p> <p><u>Bidder has to submit a certificate certifying following along with offer:</u></p> <p><i>“I have read the clause regarding restrictions on procurement from a bidder of a country which shares a land border with India; I certify that bidder (..... Name of Bidder) is not from such a country or, if from such a country, has been registered with the Competent Authority. I hereby certify that bidder (..... Name of bidder) fulfils all requirements in this regard and is eligible to be considered”</i></p> <p>If the bidder is from such country which shares a land border with India evidence of valid registration by the Competent Authority shall also be attached along with offer.</p>
12.	E-Invoice	<p>Vendor Contract clause regarding GST ITC and provision for E-invoices w.e.f. 01.04.2021</p> <p>E-invoicing under GST is being implemented w.e.f. 01.04.2021 for all the taxable persons having turnover more than Rs. 50 Cr. It has been specified by the Govt. that it is mandatory to mention a valid unique Invoice Reference No. (IRN) and QR code as generated from Govt. portal on a Tax Invoice. Based on such information, GST ITC as claimed by BHEL in GST Returns shall be matched with the corresponding details uploaded by supplier in E-invoicing System.</p> <p>In case the vendor /contractor delays or fails to provide all the documents as per the Purchase order / Work Order at the time of submitting Tax invoice to BHEL, any subsequent financial loss to BHEL on account of vendor/contractor shall be to vendor's / contractor's account. BHEL has further right</p>

		to take necessary steps to protect its interest at the time of release of payment. This further requires inclusion of IRN and QR code on tax invoice as announced by Govt. of India w.e.f. 01.04.2021.
13.	Reverse Auction	Not applicable
14.	Latest Updates	Latest updates on the important dates, Amendments, Correspondences, Corrigenda, Clarifications, Changes, Errata, Modifications, Revisions, etc. to Tender Specifications will be hosted in BHEL e-tender portal https://eprocurebhel.co.in/nicgep/app and not in the newspapers. Bidders to keep themselves updated with all such information

Please submit your offer only for the above requirement subject to our **GENERAL INSTRUCTIONS AND STANDARD TERMS & CONDITIONS (GISTC: Version June-21, Rev: 06)**. Please visit our site www.hwr.bhel.com for General Instructions and Standard Terms & Conditions (GISTC) for Tender Enquiries. All the bidders/vendors must ensure compliance of these GISTC. GISTC can also be referred by login to B2B Portal for Registered Vendors.

Tender Fee - INR 2000.00 (If hard copy of tender document is required from BHEL)

EMD –Not Applicable

E-Procurement Portal Inputs

Procedure for Submission of Offer for E – Tender-Procedure for Submission of Tender is available in the “Bidder Manual for BHEL Bidders” at E-tender portal <https://eprocurebhel.co.in/nicgep/app>. Terms and conditions mentioned therein shall form integral part of the NIT and bidders shall abide by the same.

1. Hardware and Software requirements for participating in e-tender

Please refer the website for the minimum system requirements and setting document for Bidders under the link: <https://eprocurebhel.co.in/nicgep/app>

2. Digital Signature

To know the procedure for obtaining Digital Signature Certificate (DSC), suppliers who are not having the DSC are advised to visit our website [http://www.bhel.com/home.php/Tender Notifications/Sample Checklist](http://www.bhel.com/home.php/Tender%20Notifications/Sample%20Checklist).

3. NIC portal Helpdesk Contacts

For any technical related queries please call at 24 x 7 Help Desk Number
 0120-4001 002
 0120-4200 462
 0120-4001 005
 0120-6277 787

International bidders are requested to prefix 91 as country code

Email Support

Address: A) For any Issues or Clarifications relating to the published tenders, bidders are requested to contact the respective Tender Inviting Authority
 Technical - support-eproc@nic.in

4. Note

Offers/tenders submitted in the E-tender portal shall only be considered for further evaluation. Offers sent by FAX / E-mail / any mode other than E-tender would not be entertained.

The Tenderers must submit their Tenders, as detailed below:

SPECIAL NOTE: All documents to be submitted should be uploaded in respective places in the E-Tender portal as per the list mentioned given in this NIT. BHEL shall not be responsible for in-complete documents.

For new vendors not registered with us **(Applicable only for open tender)**, kindly furnish copy of following documents:

- Company Name and Address Proof.
- GST Number (Scan Copy of Acknowledgement)
- PAN Copy
- MSME Certificate (UAN, Udyam if Any)

Commercial Term & Condition Compliance

Tender Reference No.	L/6451/2022/0142/D2, Due date: 27.08.2022		
Item Description	Grooving Tool		
Vendor Name			
Quotation Reference no.		Date	

<u>Sl. No.</u>	<u>Techno-Commercial terms</u>	<u>Vendor Confirmation</u>
1.	Please specify whether you are manufacturer or Trader of the item.	
2.	Material will be supplied as per BHEL Specification mentioned in enquiry. Manufacturing, Testing and Certification will be as per ordering specification, if not accepted, then mention deviation.	
3.	<u>For Indian Bidder, Delivery Terms:</u> (BHEL Standard term: FOR Destination means CPS/HEEP/ BHEL Haridwar)	

	For Foreign Bidder, Delivery Terms: CIF Nhava Sheva Sea Port. If any other delivery terms (FCA/FOB etc), Pl. mention	
4.	For Indian Bidder, Despatch mode: (BHEL Standard term: Through BHEL approved transporter only) For Foreign Bidder, Despatch mode : SEA/AIR	
5.	Origin of Despatch	
6.	Freight Charges ➤ Loading shall be done as per extent rules of BHEL-Haridwar, if Freight is mentioned as 'To Pay'	
7.	Packing Charges ➤ Loading shall be done as per extent rules of BHEL-Haridwar, if Packing charges is 'Extra'	
8.	Forwarding Charges ➤ Loading shall be done as per extent rules of BHEL-Haridwar, if Forwarding charges is 'Extra'.	
9.	Delivery Period in weeks/months (Lead Time from PO date)	
10.	Payment term: "100% payment after receipt & acceptance of material at BHEL HEEP Haridwar". ➤ If vendor deviates from BHEL's standard payment term, loading on account of deviation in standard payment term shall be done as per extent rules of BHEL-Haridwar (Refer GISTC)	
11.	Bank Charges ➤ If BHEL's Standard Payment terms accepted then bank charges not applicable, otherwise please mention	
12.	Rate of GST (CGST/SGST/IGST) extra in % (for Indian Bidder only)	
13.	Test certificate (if applicable) as per Specification shall be provided.	
14.	Guarantee Certificate (if applicable) shall be provided	
15.	Liquidated Damages (LD) for Late Deliveries shall be applicable @0.5% per week or part thereof on the value of respective delayed supplies subject to maximum of 10% of the value of respective delayed supplies. If vendor do not mention anything about LD clause in their offer, then it shall be presumed to be acceptable. No further clarification shall be asked in this regard after opening of techno-commercial bid part-1. If vendor don't accept this clause, then loading shall be done as per extent rules of BHEL-Haridwar.	
16.	Quotation Validity ➤ As per NIT, Validity is 90 days from techno-commercial bid opening date.	
17.	Currency (Pl. mention unit of Currency as mentioned in offer)	
18.	The evaluation currency for this tender shall be INR. (Currency exchange rate at time of Part-1 Bid to be considered)	
19.	Are you registered under Micro Small Enterprises (MSE vendor)? if Yes then provide Udyam Certificate (for Indian Bidder only)	
20.	Any other comments (like any other charges, order to be placed on etc.)	
21.	BHEL reserve the right to change the quantity/ Part quantity at the time of ordering.	
22.	Vendor to ensure that their quoted rates are not more than those quoted	

	for any other customer including other BHEL units.	
23.	Vendor to declares that they will not enter into any illegal or undisclosed agreement or understanding, whether formal or informal with other Bidder(s). This applies in particular to prices, specifications, certifications, subsidiary contracts, submission or non-submission of bids or any other actions to restrict competitiveness or to introduce cartelization in the bidding process. In case, the Bidder is found having indulged in above activities, suitable action shall be taken by BHEL as per extant policies/ guidelines.	
24.	Rest terms and condition shall be as per latest General Instructions and Standard Terms & Conditions (GISTC) for bidding against Tender Enquiry for Indian/Foreign Bidders (Version June-2021, Rev: 06).	
25.	Vendor to ensure compliance of each and every points of Pre-Qualifying Requirement and submit offer accordingly.	
26.	Vendor to quote best possible delivery in the offer. Early delivery is also acceptable. Delivery schedule is not sacrosanct.	
27.	PO No. &/or Vendor's Emblem/seal shall be clearly punch marked/Etched on each item.	
28.	Price Bid shall be opened for only those bidders who qualifies PQR (Pre-Qualifying Requirement) and whose techno-commercial bid is acceptable to BHEL.	
29.	In case of any difference in conditions quoted above & elsewhere in the offer, terms quoted above shall be treated as final and binding on vendor.	

Sign and Seal of the Bidder

ANNEXURE-1**Items details of the Enquiry:**

Items details shall be as under. Vendor to submit the offer as per items description/specification mentioned against each item.

Sl. No.	Material Code	Item Description	Qty. (NO)	Delivery Schedule
1	AAA212600567	GROOVING TOOL. DRG.NO-R2126-0056.	10	15.04.2023
2	AAA217700454	GROOVING TOOL. DRG.NO.R2177-0045. N.STD:SPT-HSS-SP SIZE: -	30	15.04.2023
3	AAB218200463	PRE MACHINING TOOL DRG.NO.-R2182-0046 REV.-02	50	31.12.2022
4	AAA217700446	GROOVING TOOL. DRG.NO.R2177-0044 N.STD:SPT-HSS-SP	15	31.12.2022
5	AAA209000937	RADIUS TOOL R60 DRG.NO.-R2090-0093	5	15.04.2023

Indent no : 2022-0142,
2021-2681,
2021-2838,
2021-2372

01.00	PRE QUALIFYING CONDITIONS	REQUIRED
01.01	a). Only those vendors to quote who are Original Equipment Manufacturers of HSS - Single Point Tools. (Authorized channel partner/associates of above OEMs may also quote on their behalf. In such case, valid Authorization Certificate issued by OEM on their letter head is to be furnished with the offer) b.) Vendors to provide satisfactory documentary proof w.r.t experience as mentioned in point 01.01.a This is required from all the vendors for qualification of their offer.	Vendor to accept/agree and provide details
01.02	Vendor to provide name, designation and contact details (phone number, email address etc.) of the customer for whom such items at Sl. No 01.01 (a) are supplied.	Vendor to accept/agree and provide details
01.03	BHEL reserves the right to verify the information provided by vendor. In case the information provided by vendor is found to be false/ incorrect, their offers shall be rejected.	Vendor to accept/agree

02.00	TECHNICAL SPECIFICATIONS	REQUIRED
02.01	Vendors to confirm that the items quoted shall be as per BHEL drawing only.	Vendor to confirm



E1/TR
राजेश कुमार
अभियन्ता (दुल रुम)
बी.एच.ई.एल.सीप, हरिद्वार

FIRST ANGLE PROJECTION (ALL DIMENSIONS ARE IN mm)

R2090-0093
DRAWING NUMBER

1.5 / THE REST

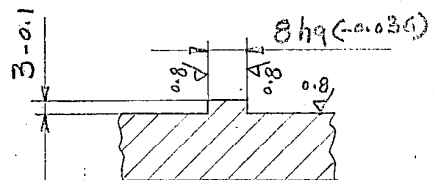
SECTION A-A



SECTION B-B

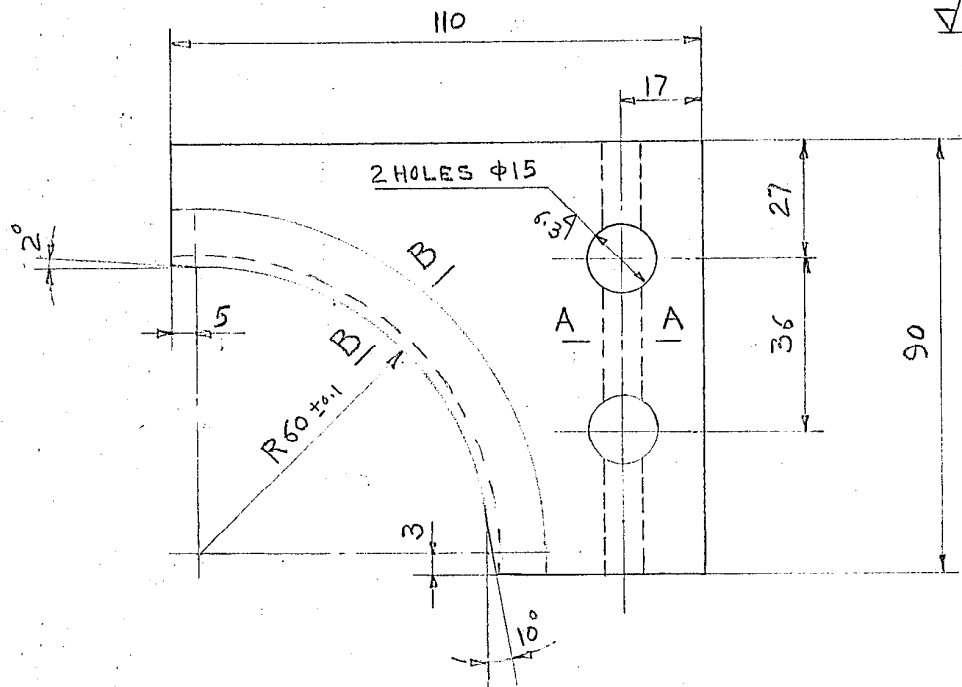
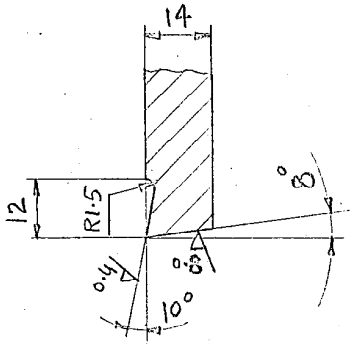

It must not be used directly or indirectly in anyway detrimental to the interest of the company.

Ref. Drg. No.

Sign. & Date

Inventory No.

- HARDEN TO HRC 62 ± 65
- TO BE USED WITH MANDREL DRG. NO. R6707-0002 (8350-271)

MARK	
R2090-0093	
R60	H.S.S

H.S.S		6-5-2-5		WT. KG.	
MAT. CODE		MAT. SPECN		QTY.	
TYPE OF PRODUCT C-200-130		W/O. NO. ST-5285		M/C. TOOL TRANS NO. 169/032021	
COMP. DRG. NO. 31303003		REF. DRG. NO. -		M/C. MODEL 1A-660	
		INVENT. NO.			

BHARAT HEAVY ELECTRICALS LTD.
RAMIPUR - HARDWAR.

S.T.T	NAME	SIGN.
	JETLYAN	

REV	DATE	ALTERED	CHECKED

DEPT. TLX	CODE 125	SCALE 1:1	WEIGHT (KG)	REF. TO ASSY. DRG.	ITEM NO.
-----------	----------	-----------	-------------	--------------------	----------

RADIUS TOOL R60
(PLATE TYPE)

Dimensions to be Controlled Within Limits as Shown
Machining Tolerance ± .25 mm Unless Otherwise Shown. Non Machining Tolerance ±

DRAWN	NAME	SIGN.	DATE
DRN	LAVHIA		
CHECKED	M. KHAN		
APPROVED	SRGUPTA		

CARD CODE	DRAWING NO. R2090-0093
SHEET NO.	NO. OF SHEETS.

COPYRIGHT AND CONFIDENTIAL
THE INFORMATION ON THIS DOCUMENT IS THE PROPERTY OF BHARAT
HEAVY ELECTRICALS LIMITED IT MUST NOT BE USED DIRECTLY
OR INDIRECTLY IN ANY WAY DETRIMENTAL TO THE INTEREST OF COMPANY.

DRAWING No. R2177-0044+0046

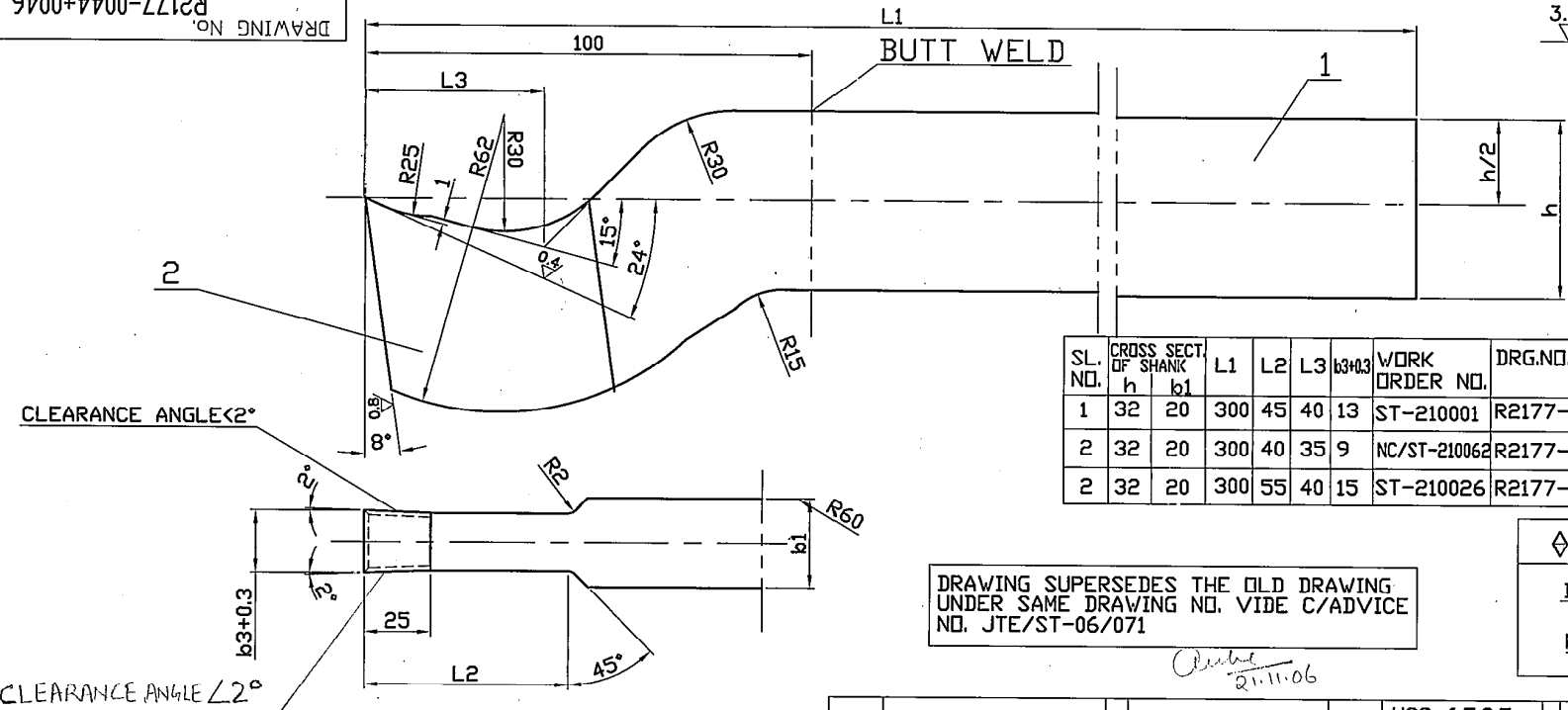

3.2
THE REST

SL. NO.	CROSS SECT. OF SHANK	L1	L2	L3	b3±0.3	WORK ORDER NO.	DRG. NO.	Wt.
1	32 20	300	45	40	13	ST-210001	R2177-0044	1.4
2	32 20	300	40	35	9	NC/ST-210062	R2177-0045	~1.0
2	32 20	300	55	40	15	ST-210026	R2177-0046	1.6

DRAWING SUPERSEDES THE OLD DRAWING UNDER SAME DRAWING NO. VIDE C/ADVICE NO. JTE/ST-06/071

◇ MARK
DRG. NO.
b3j HSS

Ambedkar
21.11.06

NOTES:-

- NON CUTTING SHARP EDGES TO BE ROUNDED OFF.
- HARDEN CUTTING PORTION TO HRC 64-68 AS PER P.S. 0912-008.
- ANY STEEL HAVING MINIMUM TENSTILE STRENGTH 70kg/mm²
- CONSERVATION TO BE DONE AS PER TL 30007.

VAR.00	REMARKS	ITEM No.	DESCRIPTION	STD	DRAWING No.	VAR.	MATERIAL SPECN.	A	UNIT	UNIT WEIGHT	QTY.
		01	SHANK				HSS 6:5:2:5 AA10815			1	
		2.	CUTTING PORTION							1	

3-7319 E
INVENTORY No. SIGN. & DATE REF. DRG. No.

GMS No./GR.SP.No.		STATUS OF DRG		TYPE OF PRODUCT		COMP. DRG. No.		M/C. TOOL TRANS No.		REF. DRG. No.							
210 MW KWU		210 MW KWU		210 MW KWU		DESIGN ORDER No. SEC TABLE		M/C MODEL No.		VE4-12-2003							
AGREED DEPT.		NAME		SIGN.		DATE		NAME		SIGN.		DATE		No. OF VAR.			
TECH. MANCHANDA		-Sd-		8.2.79				DRN RAGHAVA		-Sd-		10.1.79		1			
WELDING-A/B/C/D		AA0621104						CHD KHAN		-Sd-		31.1.79		1			
GAS CUTTING-'T3'		AA0621101						APD S.K.GUPTA		-Sd-		1.3.79		1			
REV. DATE		ALTERED		REV. DATE		ALTERED		DEPT. JTE		SCALE		WEIGHT(Kg)		REF. TO ASSY. DRG.		ITEM No. OF	
		CHECKED				CHECKED		CODE 209		NTS		SEE TABLE				No. OF ITEMS	
														DRAWING No. R2177-0044+0046		REV	
														SHEET No. 01		No. OF SHEETS 01	

BHEL BHARAT HEAVY ELECTRICALS LTD.
HARDWAR

TITLE
ROUGH GROOVING TOOL FOR
BLADE GROOVES

COPYRIGHT AND CONFIDENTIAL
THE INFORMATION ON THIS DOCUMENT IS THE PROPERTY OF BHARAT
HEAVY ELECTRICALS LIMITED IT MUST NOT BE USED DIRECTLY
OR INDIRECTLY IN ANY WAY DETRIMENTAL TO THE INTEREST OF COMPANY.

DRAWING No. R2177-0044+0046

3.2 THE REST

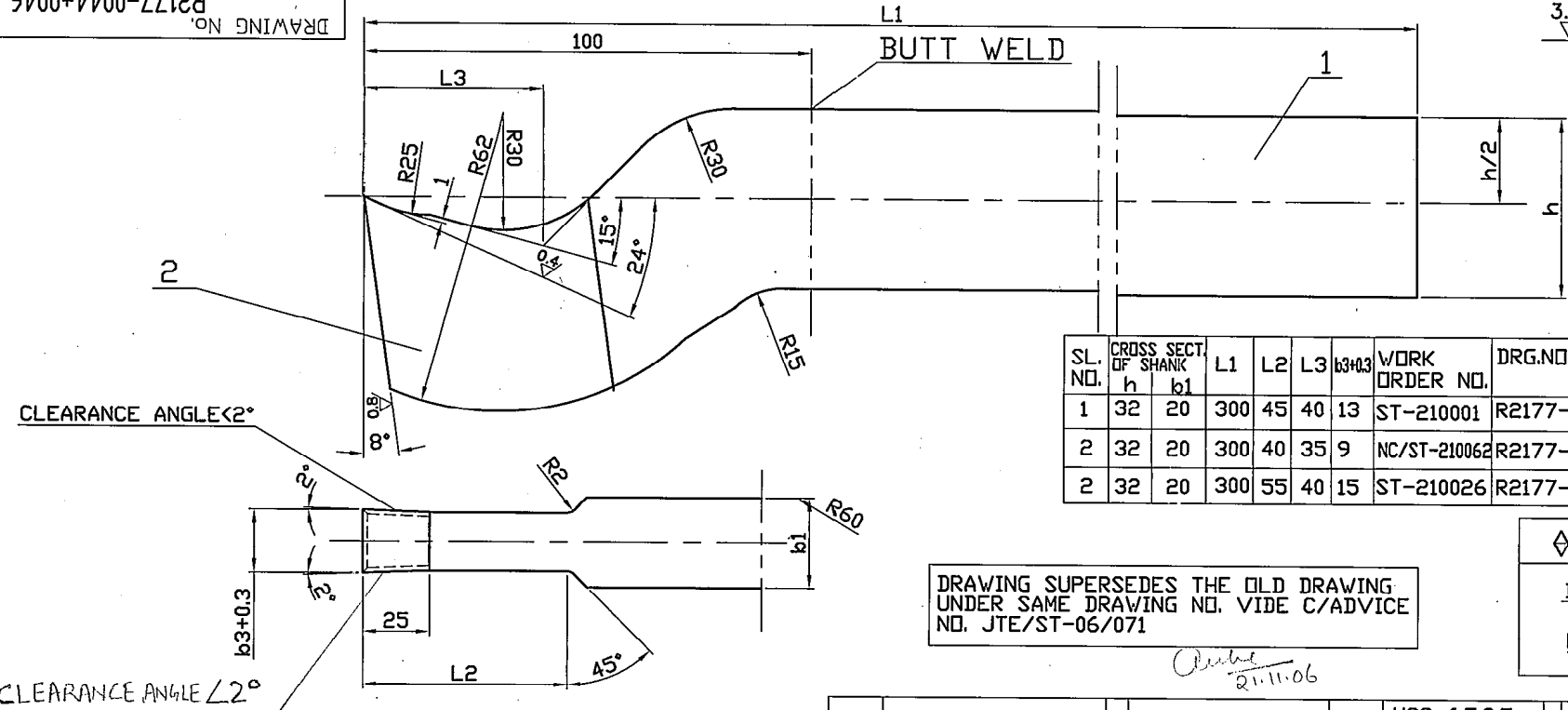

SL. NO.	CROSS SECT. OF SHANK h b1	L1	L2	L3	b3+0.3	WORK ORDER NO.	DRG. NO.	Wt.
1	32 20	300	45	40	13	ST-210001	R2177-0044	1.4
2	32 20	300	40	35	9	NC/ST-210062	R2177-0045	~1.0
2	32 20	300	55	40	15	ST-210026	R2177-0046	1.6

DRAWING SUPERSEDES THE OLD DRAWING UNDER SAME DRAWING NO. VIDE C/ADVICE NO. JTE/ST-06/071

◇ MARK
DRG. NO.
b3; HSS

21.11.06

NOTES:-

- NON CUTTING SHARP EDGES TO BE ROUNDED OFF.
- HARDEN CUTTING PORTION TO HRC 64-68 AS PER P.S. 0912-008.
- ANY STEEL HAVING MINIMUM TENSTILE STRENGTH 70kg/mm²
- CONSERVATION TO BE DONE AS PER TL 30007.

VAR.00	REMARKS	ITEM No.	DESCRIPTION	STD	DRAWING No.	MATERIAL CODE	A	UNIT	UNIT WEIGHT	QTY.
		01	SHANK			HSS 65i25				1
		2.	CUTTING PORTION			AA10815				1

3-7319 E INVENTORY No. SIGN.&DATE REF. DRG. No. 21/11/06

GMS No./GR.SP.No.		STATUS OF DRG		TYPE OF PRODUCT		COMP. DRG. No.		M/C TOOL TRANS No.		REF. DRG. No.	
AGREED DEPT. NAME SIGN. DATE		TECH. MANCHANDA -Sd- 8.2.79		210 MW KWU		DESIGN ORDER No. SEE TABLE		M/C MODEL No.		VE4-12-2003	
GRADE OF UNTOL. DIM.:-				M/CG- P/M AA0230208				WELDING-A/B/C/D AA0621104			
GAS CUTTING-'T3' AA0621101				DEPT. JTE				SCALE NTS			
REV DATE ALTERED CHECKED		REV DATE ALTERED CHECKED		CODE 209		WEIGHT(Kg) SEE TABLE		REF.TO ASSY. DRG.		ITEM No. REV	
MATERIAL SPECN. VAR.				BHEL BHARAT HEAVY ELECTRICALS LTD. HARDWAR				DRAWING No. R2177-0044+0046		SHEET No. 01 No. OF SHEETS 01	

COPYRIGHT AND CONFIDENTIAL
THE INFORMATION ON THIS DOCUMENT IS THE PROPERTY OF BHARAT
HEAVY ELECTRICALS LIMITED IT MUST NOT BE USED DIRECTLY
OR INDIRECTLY IN ANY WAY DETRIMENTAL TO THE INTEREST OF COMPANY.

FIRST ANGLE PROJECTION

(ALL DIMENSIONS ARE IN mm)

FORM DG38(B)

1.6/ THE REST

DRAWING No. R2182-0046

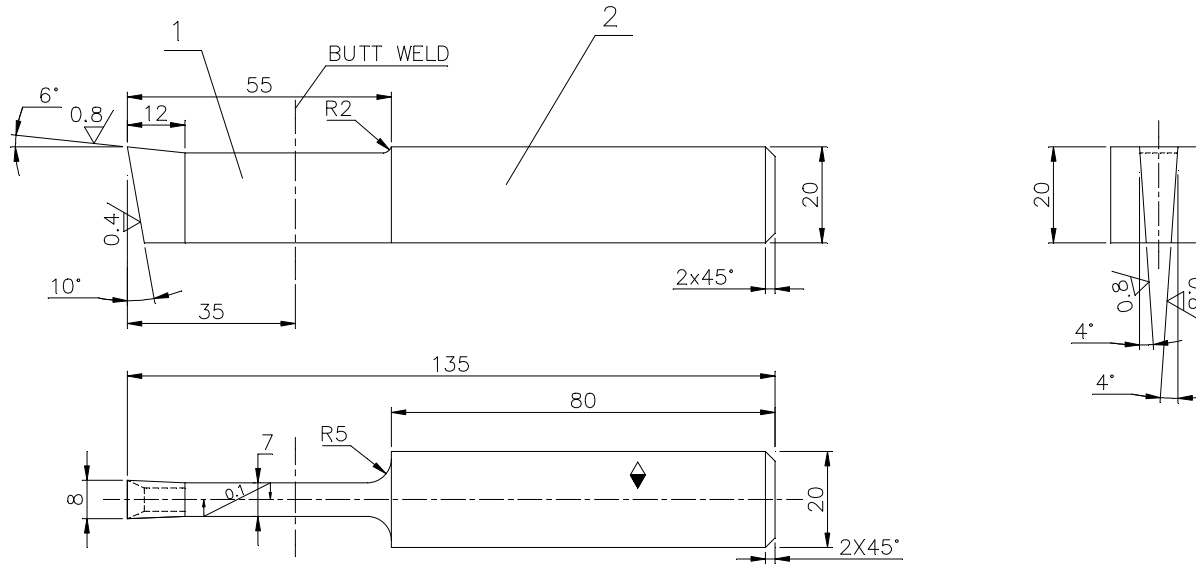

REDRAWN FROM ORIGINAL

MARK
R2182-0046
H.S.S.

NOTES: -

- HARDEN THE CUTTING PORTION TO HRC 62±65 AND SHANK TO HRC 35±40.
- NON-CUTTING SHARP EDGES TO BE ROUNDED OFF.

* 3. ANY STEEL HAVING MINIMUM TENSILE STRENGTH 75Kg/MM?

002	SHANK	---	*	01		
001	CUTTING PORTION	---	H.S.S 6: 5: 2: 5	01		
ITEM No.	DESCRIPTION	STD	DRAWING No.	MATERIAL CODE	A UNIT	UNIT WEIGHT
				VAR.	MATERIAL SPECN.	QTY.

3-11060 INVENTORY No. SIGN.&DATE REF. DRG. No.

GRADE OF UNTOL. DIM.: -		GMS No./GR.SP.No.		STATUS OF DRG.		TYPE OF PRODUCT		COMP. DRG. No.		M/C TOOL TRANS No.		REF. DRG. No.	
M/CG-℄/M/F/AA0230208		AGREED DEPT. STT		NAME J.P.GUPTA		SIGN. -Sd-		DATE		500 MW (KWU)		9-102-04-05000	
WELDING-A/B/C/D AA0621104		DESIGN ORDER No. STC-1015		M/C MODEL No.		SHAPER721		REF. DRG. No. R2182-0025		DRN M.P.S.		SIGN. -Sd-	
GAS CUTTING-'T3' AA0621101		REV DATE		ALTERED CHECKED		SJTERS AJTEAM		DEPT. TLX CODE 125		SCALE 1:1		WEIGHT(Kg)	
REV DATE		02 17.12.15		DRG. REDRAWN FROM ORIGINAL VIA C/A No. JTE-15-F0116		TITLE PRE MACHINING TOOL FOR INSERTION GROOVES		REF. TO ASSY. DRG.		DRAWING No. R2182-0046		REV. No. OF ITEMS	
SHEET No. 01		No. OF SHEETS 01		SIZE A 3		BINOD ROY -Sd- 07.10.86		APD					