



Bharat Heavy Electricals Limited  
Boiler Auxilaries Plant,  
Ranipet –632 406  
Civil Projects & Services

TENDER NOTICE NO:BAP-CFD-04/2008-09 DATED 16.05.2008

Sealed tenders are invited for the following works from those contractors who have experience in **Design, fabrication and Erection of Pre-Engineered Buildings (PEB) inside Factory** for Government Departments, Government Undertakings, reputed private sectors etc., as per the eligibility criteria specified.

Sl. No.	Name of Work	Period of Completion
01	New Fabrication Bay in Factory.	8 Months
02	New Rolling Bay in Factory	8 Months

The EMD for total works are Rs.2,00,000/- and shall be collected in the form of Pay order or Demand Draft only.

Tender documents (non-transferable) may be received from the office of the Deputy General Manager (Civil Factory & Designs) **from 19.05.2008** on remittance of Rs.500/-(non-refundable). Tender documents may also be down loaded from BHEL web site [www.bhel.com/tender/list\\_tender.php](http://www.bhel.com/tender/list_tender.php)

BHEL will **not be responsible** for any loss/delay of documents sent by post.

Time is the essence of contract. Any delay beyond the delivery date will attract Liquidated Damages as per GCC.

Separate Technical and Commercial bids in sealed covers will be received at the Office of **The Dy. Gen.Manager Civil Factory BHEL Ranipet up to 11.00 AM on 10.06.2008. The Eligibility criteria bid will be opened immediately and the Technical bid will be opened at 3.00 P.M. on the same day** in the presence of tenderers who may choose to be present. The commercial bids of the technically accepted tenderers will be opened at the appointed time duly intimated later.

For clarification if any, Deputy General Manager/Civil Factory & Designs at the above address or in Phone Nos : 04172 – 242026 & 254694, may be contacted.

Any Change/s and / or Corrigenda to the Tender Enquiry including change of tender opening date, if any, would be hosted on the web only. No separate publication in the newspapers or notice through other media would be given to the intending bidders by BHEL.

The purchaser shall be under no obligation to accept the lowest or any other tender and shall be entitled to accept or reject any tender in part or full without assigning any reason whatsoever.

The prices quoted shall be firm and inclusive of all taxes and duties. No price variation on any account shall be entertained during the contract period.



Bharat Heavy Electricals Limited  
Boiler Auxiliaries Plant,  
Ranipet –632 406  
Civil Projects & Services

**ELIGIBILITY CRITERIA FOR PRE- ENGINEERED BUILDING at BHEL, RANIPET**

- 1) Annual report for the last 3 years
- 2) Experience of having successfully completed similar works during the last 7 years as on 31.03.2008 for Government Departments, Government Undertakings **reputed private sectors** etc.
- 3) The contractor shall possess a solvency certificate from their bankers for Rs.15 crores.
- 4) The contractor should have executed at least a single PEB of not less than Rs.10 crores in contract in the last preceding 3 yrs.
- 5) The turnover of the contractor shall be a minimum of 40 crores for each preceding 3 financial years.
- 6) The contractor should possess his own pre-engineering building components manufacturing facility and design capability.
- 7) The contractor shall have designed & supplied PEB's a minimum of 50 tonnes or higher.
- 8) Certificate from customers/end users for satisfactory performance of the work.
- 9) List of customers with contract details.
- 10) Contractors who have designed and supplied PEB's conforming to IS 800 shall only be considered. The PEB design shall be vetted by IIT, Chennai at the contractor's cost.

**Tender bids not meeting any of the above pre -qualification criteria shall be rejected.**



Bharat Heavy Electricals Limited  
Boiler Auxilaries Plant,  
Ranipet –632 406  
Civil Projects & Services

Questionnaire to be answered by the tenderer by ticking the suitable boxes.

Sl.No.	Description	Yes	No
01	Whether the tenderer has understood the scope of work and agrees to deploy manpower as indicated in the tender. (If there is any clarification required, the same may be got cleared from the Executive-in-charge, before submitting the offer.)		
02	Whether the tenderer has agreed to all Terms & Conditions given in the tender. (If there is any deviation, the same may be mentioned in separate sheet.)		
03	Whether the tenderer has their own code for ESI & PF. (A copy of the certificate to be enclosed).		
04	Whether the tenderer has enclosed copy of the present Service/Sales/Works contract sales Tax registration certificates. If a vendor is exempted from the registration under Service/Sales Tax, the reason there of be stated.		
05	Whether the vendor/Contractor is availing service Tax credit/VAT Credit for their inputs.		
06	Whether the vendor will submit VAT/Service Tax invoice as per the existing ACT and the rules their under.		
07	Whether the tenderer agrees to Pay Wages as per Minimum wages Act, EL Wages, Holiday Wages as per Tamilnadu Factory rules. (Necessary proof should be submitted while claiming running bill and final bill.)		
08	Whether the PAN Number of the vendor is furnished. If exempted from IT, the exemption certificate shall be enclosed.		
09	Whether the tenderer agrees to keep the validity of their offer for three months from the date of opening of bid and keep the prices firm throughout the contract period.		
10	Whether the tenderer agrees for the payment terms BHEL.		
11	Whether the tenderer has agreed to submit EMD of Rs.2,00,000/- and has submitted the same along with technical bid. (If not enclosed the tender will not be considered).		
12	Whether the tenderer has agreed to submit Security Deposit immediately after receipt of the work order.		
13	Whether the tenderer has enclosed the list of their clients with addresses & contact persons.		



Bharat Heavy Electricals Limited  
Boiler Auxilaries Plant,  
Ranipet –632 406  
Civil Projects & Services

14	Whether the tenderer has enclosed the completion certificates received from Government/Reputed organization for the similar work done for the last 7 years ending 31.03.2008.		
15	Whether the tenderer has enclosed the list of similar works carried out with supporting documents		
16	Whether the inculdibility/excludability of the taxes and duties in the rates offered has been clearly indicated. If the same is not done, BHEL will choose to assume the rates are inclusive only.		
17	All payments will be made through e-payment only for which required certificate to be submitted as enclosed will be submitted by the vendor on receipt of the order		
18	Whether the tenderer has enclosed the list of technical personnel, their qualification & experience who will be deployed for this work.		
19	Whether the tenderer has indicated the address of their local office in Ranipet along with phone no. & fax no.		
20	Whether the tenderer has enclosed the solvency certificate obtained from a bank for a value of Rs. 15 crores minimum.		
21	Whether the tenderer has enclosed he DD towards the cost of Tender Document, along with the Technical bid. (In case the tenderer has downloaded the tender document directly from the Web Site. If not enclosed the tender will not be considered).		
22	Whether the tenderer accepts reverse auctioning process through internet.		
23	Whether the tenderer has enclosed the annual report for the last three years,		
24	Whether the tenderer has submitted the proof of having completed a single work order value more than 10 Crores.		
25	Whether the tenderer has submitted the proof of turnover for last 3 years for a value of more than 40 Crores.		
26	Whether the tenderer has submitted the proof of having their own manufacturing facility for making pre engineered building components.		
27	Whether the tenderer has enclosed the proof of having designed and executed crane capacity of 50T or more.		
28	Whether the tenderer has enclosed the proof of having designed the PEB at least one building as per IS 800.		

Note: If any of the question is not applicable, please mention as "Not Applicable"



Bharat Heavy Electricals Limited  
Boiler Auxilaries Plant,  
Ranipet –632 406  
Civil Projects & Services

## SECTION - 1 - TECHNICAL SPECIFICATIONS FOR PEB BUILDING

### CONTENTS

SECTION Nos.	DESCRIPTION	PAGE
A	INSTRUCTIONS TO TENDERERS	6
B	SCOPE OF WORK	21
C	BUILDING DESCRIPTION	24
D	DESIGN SPECIFICATIONS	26
E	PARTICULAR SPECIFICATIONS	30
F	MATERIALS & PAINTING SPECIFICATIONS	51



Bharat Heavy Electricals Limited  
Boiler Auxilaries Plant,  
Ranipet –632 406  
Civil Projects & Services

## **SECTION - A**

### **INSTRUCTIONS TO TENDERERS**

#### **1.1. Pre-bid Conference:**

- 1.1.1 Pre-bid conference of the prospective tenderers will be held on 26.05.2008 at 11.00 A.M. in the office of DGM/CIVIL FACTORY/BHEL/ Ranipet for clarifications of any doubts. On any conditions of the contract, specifications etc.
- 1.1.2 The tenderer or his official representative is advised to attend the pre-bid conference on the date mentioned above.
- 1.1.3 Any modification arising out of the pre-bid conference shall be formalized by issue of amendments to the Tender Documents.

#### **THREE ENVELOPE SYSTEM:**

##### **2.0 ELIGIBILITY CRITERIA**

Documents related to eligibility criteria like work orders, completion certificates, balance sheets, banker's certificate, proof of having designed and executed crane girder of 50 t or more, proof of owning the manufacturing facility and check list etc., to be submitted in **envelope no. 1 and shall be enclosed in the eligibility criteria envelope**

#### **MANDATORY COMMERCIAL ACCEPTANCE TERMS**

##### **Terms of Payment:**

- 1) 80% progress payment on receipt of PEB components at site on pro-rata basis against approved BOQ. The payments shall be released within seven days of their certification by BHEL site engineer.
- 2) 10% on erection on pro rata basis of identified PEB components.
- 3) 10% on successful commissioning and handing over of the PEB against a performance bank guarantee valid up to the warranty period of one year.

##### **Loading for non-acceptance of payment terms:**

Offers with deviations to the standard payment terms will be loaded @ 1% per month for the deviated amount for the deviated period for the purpose of evaluating the lowest bidder. Request for advance payment shall not be considered nor liability towards interest accepted.

##### **Corporate Warranty:**

The tenderer shall furnish Corporate Guarantees for;

- a) Roof: 10 years for leak proof ness.
- b) Frames:10 years for stability



Bharat Heavy Electricals Limited  
Boiler Auxilaries Plant,  
Ranipet –632 406  
Civil Projects & Services

**Compensation for delay:**

For any delay beyond the contracted delivery, the tenderer shall pay at the rate of ½ percent per week subject to a maximum of 10 % of the contract value.

**Loading factor for non-acceptance of compensation for delay clause:**

Offers which deviate from this clause, will attract maximum 10% loading on the offer and accordingly proportionate percentage will be loaded for accepting lesser percentage of compensation for delay clause. Example: If the tenderer has accepted for maximum 5% compensation for delay clause, then balance 5% will be loaded for evaluating lowest bidder.

**Nature of award of Contract:**

Only an indivisible contract shall be executed including supply, erection and handing over. No other form of contract shall be entertained.

**Material:**

Before commencing fabrication, the tenderer shall obtain BHEL's prior approval for the usage of material. The tenderer shall produce necessary documentation (material test reports). The material should be sourced from the under mentioned sources preferably.

Steel for Frames- Essar Steel/Jindal/SAIL/ISPAT/Tata

Roof and wall cladding coils- Zinc alum of Bluescope/NIPPON/Union Steel.

**Taxes & Duties:** These shall be paid / reimbursed. The Tenderer shall furnish tariff headings of the statutory levies clearly in his offer and also the value of the offer liable for such duties/taxes.



Bharat Heavy Electricals Limited  
Boiler Auxiliaries Plant,  
Ranipet –632 406  
Civil Projects & Services

### **3.0: TECHNICAL BID:**

#### **3.1 The Technical bid will comprise the following:**

- i. The general approach and methodology proposed for carrying out the items covered in the Scope of work should be submitted, including such detailed information as deemed relevant. Apart from the above, contractor shall give details and number of equipments, to be mobilized to complete work as per specifications, in stipulated time schedule.
  - ii. Detailed overall work programme and a bar chart indicating the duration and timing of all major activities showing the desired milestones.
  - iii. General arrangement drawing of all buildings showing all structural and non structural elements mentioned in the scope.
  - iv. List of codes of standards in addition to those mentioned in the specifications.
- 3.2. The tenderers shall submit the quality assurance plan duly signed by the corporate head or any other authorized person.
- 3.3. No information relating to financial terms of services should be included in the Technical bid. Proposals are to be submitted to determine that the tenderer has a full comprehension of the work the contract. Where a tenderer's technical submittal is found non-complaint with the requirement or work it may be rejected. This process is to assure that only technically acceptable proposals are considered for the work.



#### **4.0 FINANCIAL BID:**

**The financial bid will comprise the following:**

- i. Tender document
  - ii. Bill of quantities.
- 4.1. The financial bid proposal should be submitted in a separate sealed envelope. The prices shall be entered in the bill of quantities attached with tender documents. These prices should include all costs associated with the contract.
  - 4.2. All documents issued for the purposes of tendering and any amendments issued shall be deemed as incorporated in the tender.
  - 4.3. The contractor shall effect and maintain professional indemnity insurance for the amount equal to Indian Rupees 25 Lakhs. The contractor shall produce evidence of coverage of the professional indemnity insurance before any payment is released. The insurance which shall insure the contractor's liability by reason of professional negligence and errors in the design of the works, shall be valid for 5 years from the date of issue of Completion certificate. The employer will not issue final payment certificate until the contractor has produced evidence that coverage of professional indemnity insurance has been provided for the aforesaid period.

#### **5.0. SUBMISSION OF TENDER:**

- 5.1. Eligibility criteria, technical bid and financial bid shall be sealed in three separate envelopes clearly marked as eligibility criteria, technical bid and financial bid. The three envelopes, shall be kept in an other envelope addressed to the DGM/Civil Factory, BHEL, Ranipet , Vellore Dt, Tamil Nadu duly Super scribing on top, Tender Number, Name of Work, Time and Date for submission and time and date for opening. The envelope should bear the name and address of the tenderer.
- 5.2. The DGM/CIVIL FACTORY will open the eligibility criteria, in the presence of tenderers or their representatives who choose to attend on date & time as mentioned in notice inviting tender.
- 5.3. The sealed technical and financial bid will be kept in the safe custody of the DGM/ Civil Factory and will be opened on a subsequent date after evaluation of eligibility criteria . Technical bids of tenderers who satisfy the eligibility criteria shall then be opened at notified time, date and place in the presence of tenderers or their representative. Financial bids of all technically found suitable offer will be opened and the date for opening of financial bids shall be informed separately.
- 5.4. Technical evaluation of technical bids submitted by tenderers shall be undertaken based on details submitted in the technical bid only. No clarification/additional information in this regard will be sought from tenderers. Tenderer shall not be required to submit their own, additional



information or material subsequent to the date of submission and such material if submitted will be disregarded. It is therefore essential that all the details are submitted by tenderer accurately and specifically in their technical bid. However, Employer reserve the right to ask any clarification from tenderers for details submitted with technical bid if it so desires during the technical evaluation.

- 5.5. The employer will, keeping in view the contents of tender documents carry out technical evaluation of submitted technical bid.
- 5.7. All technically acceptable tenders will be eligible for opening of their Financial Bids. DGM/Civil Factory will notify all successful tenderers to attend the opening of the Financial Bids. The financial bids will then be opened in front of attending tenderers and all prices recorded.
- 5.8. **BHEL proposes to go for reverse auctioning among the technically qualified**

**bidders who have been sort listed after technical bid evaluation.**

#### **BUSINESS RULES FOR REVERSE AUCTION**

1. **SCOPE:** Design, detailed engineering, fabrication, supply, erection and handing over of Pre-Engineered Buildings (PEBs) for the following requirements to true line and level as directed by the Engineer-in-charge.
2. **SCHEDULE FOR REVERSE AUCTION:** The Reverse Auction is scheduled on – date will be informed later.
  - **Initial Auction Time**
  - **Auction Close Time : Will be informed later.**
3. **AUCTION EXTENSION TIME:** If a bidder places a Bid in the last 5 minutes of Closing of the Auction, the auction shall get extended automatically for another 5 minutes. In case, there is no Bid in the last 5 minutes of closing of Auction, the Auction shall get closed automatically without any extension.
4. **BID PRICE:** The Bidder has to quote the total lumpsum price (inclusive of design, fabrication supply to site, erection and all taxes and duties) for the Items specified in *Annexure I.* & as per excel working sheet
5. **BIDDING CURRENCY AND UNIT OF MEASUREMENT:** Bidding will be conducted in Indian rupees for the scope and the specifications mentioned in *Annexure- I* & as per excel working sheet.
6. **OPENING PRICE:**
  - **Initial Auction:** The bidders are required to quote the same Price as quoted in the sealed Bid. BHEL shall evaluate the quotes from Vendors and shall arrive at an Opening Price for the dynamic auction. The bidders shall confirm in writing to BHEL that their opening bid shall be same as that quoted in their final sealed price bid submitted against this tender. If it is found to be otherwise at a later date, the bidder will be disqualified from the tender



Bharat Heavy Electricals Limited  
Boiler Auxiliaries Plant,  
Ranipet –632 406  
Civil Projects & Services

- **Final Auction:** There shall be an Opening Price in this type of auction. The Opening Price shall be displayed at the start of the auction. Bidders are required to quote lower than the Opening Price.
7. **BID DECREMENT:** The Bid Decrement for the Final Auction shall be available to the bidders at the start of the Final auction. There shall be no Bid Decrement for the Initial Auction.
  8. **TECHNICAL AND COMMERCIAL TERMS:** The technical & commercial terms are as per BHEL tender for PEBs. Vendors technical and commercial bid and subsequent correspondences/mutual agreement between BHEL and the vendors regarding commercial terms & conditions.
  9. **VALIDITY OF BIDS:** The Bid Price shall be firm for a period of 90 days and shall not be subjected to any change whatsoever.
  10. **POST AUCTION PROCEDURE:** BHEL will proceed with the Lowest Bid in the Reverse Auction as per the normal procedure.



Bharat Heavy Electricals Limited  
Boiler Auxilaries Plant,  
Ranipet –632 406  
Civil Projects & Services

## **REVERSE AUCTION TERMS & CONDITIONS**

1. **LOG IN NAME & PASSWORD:** Each Bidder is assigned a Unique User Name & Password by e-PROCUREMENT TECHNOLOGIES. The Bidders are requested to change the Password and edit the information in the Registration Page after the receipt of initial Password from e-PROCUREMENT TECHNOLOGIES. All bids made from the Login ID given to the bidder will be deemed to have been made by the bidder.
2. **BIDS PLACED BY BIDDER:** The bid of the bidder will be taken to be an offer to sell. Bids once made by the bidder cannot be cancelled. The bidder is bound to sell the material as mentioned above at the price that they bid. Should any bidder back out and not make the supplies at per the rates quoted, BHEL and / or e-PROCUREMENT TECHNOLOGIES. Ltd. shall take action as appropriate. In case the bidder submits more than one bid, the lowest bid will be considered as the bidder's final offer to sell.
3. **AUCTION TYPE:** Initial Auction shall be Sealed Bid Reverse, in which there is no Opening Price & the Bid Decrement. The Bidders are required to quote the same Price as quoted in the Sealed bid submitted to BHEL. Final Auction shall be English (No Ties) Reverse, in which there shall be an Opening Price and the Bid Decrement. The Bidders are required to quote lower than the Opening Price based on the Bid Decrement.
4. **VISIBILITY TO BIDDER:** The Bidder shall be able to view the following on his screen along with the necessary fields:
  - Leading Bid in the Auction
  - Bid Placed by him
5. **AUCTION WINNER:** At the end of the Reverse Auction, BHEL will evaluate all the bids submitted and will decide upon the winner.
6. **OTHER TERMS & CONDITIONS :**
  - The Supplier / Bidder shall not involve himself or any of his representatives in Price manipulation of any kind directly or indirectly by communicating with other suppliers / bidders.
  - The Bidder shall not divulge either his Bids or any other exclusive details of BHEL to any other party.
  - BHEL's decision on award of Contract shall be final and binding on all the Bidders.
  - BHEL reserves the right to finalize the contract based on reverse auction bids or the sealed price bids submitted along with offer.
  - BHEL along with e-PROCUREMENT TECHNOLOGIES PVT LTD can decide to extend, reschedule or cancel any Auction. Any changes made by BHEL and / or e-PROCUREMENT TECHNOLOGIES after the



Bharat Heavy Electricals Limited  
Boiler Auxilaries Plant,  
Ranipet –632 406  
Civil Projects & Services

first posting will have to be accepted if the Bidder continues to access the site after that time.

- e-PROCUREMENT TECHNOLOGIES shall not have any liability to Bidders for any interruption or delay in access to the site irrespective of the cause.
- e-PROCUREMENT TECHNOLOGIES is not responsible for any damages, including damages that result from, but are not limited to negligence. e-PROCUREMENT TECHNOLOGIES will not be held responsible for consequential damages, including but not limited to systems problems, inability to use the system, loss of electronic information etc.

N.B.

All the Bidders are required to submit the Agreement Form (Annexure - II) duly signed to e-PROCUREMENT TECHNOLOGIES Pvt. Ltd. After the receipt of the Agreement Form, Log in ID & Password shall be allotted to the suppliers (bidders).

- After the completion of the Auction event, all the Bidders have to submit the Price Breakup immediately to e-PROCUREMENT TECHNOLOGIES Pvt. Ltd. for further proceedings.



**ANNEXURE- I**

The List of Items to be procured along with the Quantities and the Auction Start Time & Close Time is as follows:

**ITEM DESCRIPTION:** Design, detailed engineering, fabrication, supply, erection and handing over of Pre-Engineered Buildings (PEBs) for the following requirements to true line and level as directed by the Engineer-in-charge.

Sl. No	SIZE	QUANTITY	OPENING PRICE (Rs. / MT)	BID DECREMENT (Rs. / MT)	AUCTION TIME
1(a)	As per BOQ	1 lot	Shall get displayed on the site during the start of the auction.	Will be informed later	Will be informed later
1(b)	As per BOQ	1 lot			
2(a)	As per BOQ	1 lot			
2(b)	As per BOQ	1 lot			
2 ©	As per BOQ	1 lot			
2 (d)	As per BOQ	1 lot			



Bharat Heavy Electricals Limited  
Boiler Auxiliaries Plant,  
Ranipet –632 406  
Civil Projects & Services

Annexure- II  
Process Compliance Form

To

M/S. e-PROCUREMENT TECHNOLOGIES PVT LTD,  
314-316, SHIROMANY COMPLEX,  
OPP.OCEAN PARK, NEHRUNAGAR CROSS ROAD,  
AHMEDABAD-380015.

***Sub: Agreement to the Process related Terms and Conditions***

Dear Sir,

This has reference to the Terms & Conditions for the Reverse Auction (BHEL Enq: 4471919E) mentioned in the Business Rules document.

This letter is to confirm that:

- 1) The undersigned is authorized representative of the company.
- 2) **We have studied** the Commercial Terms, **Excel Working Sheet** and the Business rules governing the Reverse Auction as mentioned in your letter and confirm our agreement to them.
- 3) We also confirm that we have taken the training on the auction tool and have understood the functionality of the same thoroughly.
- 4) We conformed that **rates are valid till 30 days from Auction date**.

We, hereby confirm that we will honor the Bids placed by us during the auction process.

With regards

Signature with company seal

Name –

Company / Organization –

Designation within Company / Organization –

Address of Company / Organization –

- Sign this document and Fax at 079-26750009



Bharat Heavy Electricals Limited  
Boiler Auxiliaries Plant,  
Ranipet –632 406  
Civil Projects & Services

#### Annexure- A

### **GENERAL TERMS AND CONDITIONS OF REVERSE AUCTION**

Against this enquiry for design, detailed engineering, fabrication, supply and erection of pre-engineered buildings (PEB) with detailed scope of supply as per enquiry specifications, BHEL may resort to “REVERSE AUCTION PROCEDURE”, i.e., ON LINE BIDDING ON INTERNET.

1. For the proposed reverse auction, technically and commercially acceptable bidders only shall be eligible to participate
2. BHEL will engage the services of a service provider who will provide all necessary training and assistance before commencement of on line bidding on Internet.
3. BHEL will inform the vendor in writing in case of reverse auction. The details of Service provider to enable them to contact & get trained.
4. Business rules like event date, time, start price, bid decrement, extensions etc. Also will be communicated through service provider for compliance.
5. Venders have to fax the compliance form in the prescribed format (provided by Service provider) before start of Reverse auction. Without this, the vendor will not be eligible to participate in the event.
6. BHEL will provide the calculation sheet (e.g., EXCEL sheet) which will help To arrive at “Total Cost to BHEL like Supply, Packing & forwarding charges, Taxes And Duties, Freights Charges, Insurance, Service Tax for Service, Erection and loading Factors (for non – compliance to BHEL standard Commercial terms & conditions) for each of the vendor to enable them to fill – in the price and keep it ready for keying in during the Auction.
7. Reverse auction will be conducted on scheduled date & time.
8. At the end Reverse Auction event, the lowest bidder value will be known on the network.
9. The lowest bidder has to Fax the duly signed Filled – in prescribed format as Provided on case – to – case basis to BHEL through Service provider within 24 Hours of auctions without fail.
10. Any variation between the on – line bid value and the signed document will be Considered as sabotaging the tender process and will invite disqualification of vendor to conduct business with BHEL as per prevailing procedure.
11. In case BHEL decides not to go for Reverse Auction procedure from this tender Enquiry, the price bids and impacts, if any, already submitted and available with BHEL shall be opened as per BHEL’ s standard practice.



Bharat Heavy Electricals Limited  
Boiler Auxiliaries Plant,  
Ranipet –632 406  
Civil Projects & Services

BHARAT HEAVY ELECTRICALS LIMITED				
BOILER AUXILIARIES PLANT				
RANIPET 632 406				
CIVIL FACTORY & DESIGNS				
Name of Work: Design, fabrication, erection of Pre-Engineered Building inside Factory				
Sl.No.	Description of work	Qty	Unit	Amount
1	Design, fabrication supply and erection of pre-engineered building as per IS: 800-2007 and relevant codes for the following buildings.			
a	<b>Alternate 1:</b> New Fabrication bay of size <b>30m x 210m</b> with EOT crane of capacity of 20T - 1 No., 100T - 1 No. and Semi gantry crane of capacity 3T - 2 Nos on one side with a detailed scope of work specified in technical specifications & drawings. The building shall be designed with a provision for future expansion.		1 Lot	
b	<b>Alternate 2:</b> New Fabrication bay of size <b>30m x 210m</b> with EOT crane of capacity of 20T - 1 No., 100T - 1 No. and Semi gantry crane of capacity 3T - 2 Nos on one side with a detailed scope of work specified in technical specifications & drawings. The building shall be designed with a provision for future expansion. ( <b>Same as Alternate 1 but i</b> ) Synthetic enamel painting in place of epoxy painting with appropriate primer, ii) Trapezoidal profile sheets in place of standing seam profile sheets, iii) Ultrasonic testing for full penetration flange to web welding for 10% in place of 100% and iv) Z purlins in place of pre-galvanized purlins).		1 Lot	
2	Design, fabrication supply and erection of pre-engineered building as per IS: 800-2007 and relevant codes for the following buildings.			
a	<b>Alternate 1:</b> Roll forming bay Same as alternate 1 but of size <b>30m x 240m</b> with EOT crane of capacity of 20 - 3 Nos. and Semi gantry crane of capacity 3T with a detailed scope of work specified in technical specifications & drawings. The building shall be designed with a provision for future.		1 Lot	



Bharat Heavy Electricals Limited  
Boiler Auxilaries Plant,  
Ranipet –632 406  
Civil Projects & Services

<p>b <b>Alternate 2:</b> Roll forming bay of size <b>30m x 240m</b> with EOT crane of capacity of 20 - 3 Nos. and Semi gantry crane of capacity 3T with a detailed scope of work specified in technical specifications &amp; drawings. The building shall be designed with a provision for future. (<b>Same as Alternate 1</b> but i) Synthetic enamel painting in place of epoxy painting with appropriate primer, ii) Trapezoidal profile sheets in place of standing seam profile sheets, iii) Ultrasonic testing for full penetration flange to web welding for 10% in place of 100% and iv) Z purlins in place of pre-galvanized purlins).</p>		1 Lot	
<p>c <b>Alternate 3:</b> Roll forming bay of size <b>30m x 210m</b> with EOT crane of capacity of 20 - 3 Nos. and Semi gantry crane of capacity 3T-2 Nos. one each on both side for the first half of the bay length with a detailed scope of work specified in technical specifications &amp; drawings. The building shall be designed with a provision for future expansion.</p>		1 Lot	
<p>d <b>Alternate 4:</b> Roll forming bay of size <b>30m x 210m</b> with EOT crane of capacity of 20 - 3 Nos. and Semi gantry crane of capacity 3T-2 Nos. one each on both side for the first half of the bay length with a detailed scope of work specified in technical specifications &amp; drawings. The building shall be designed with a provision for future expansion. (<b>Same as Alternate 2</b> but i) Synthetic enamel painting in place of epoxy painting with appropriate primer, ii) Trapezoidal profile sheets in place of standing seam profile sheets, iii) Ultrasonic testing for full penetration flange to web welding for 10% in place of 100% and iv) Z purlins in place of pre-galvanized purlins).</p>		1 Lot	



Bharat Heavy Electricals Limited  
Boiler Auxiliaries Plant,  
Ranipet –632 406  
Civil Projects & Services

## **6.0 INTERFACES:**

The scope of work for the interfaces work for various interfacing Contracts are detailed below, the interfaces include but are not limited to:

- a. Supply of foundation anchor bolts to Civil Contractor
  - b. Interfacing with Civil & Electrical Contractors.
- 6.1. The rates are inclusive of all cost but not limited to the cost such as for plants, Equipments, tools, all type of labours, supervision, all materials from the source of supplies as approved by Engineer in charge/Employer including all lead and lifts, transport, all temporary works, erection maintenance, contractors profits & establishments/overheads together with preparation of designs and drawings pertaining to casting yard et. All general risks, taxes, royalties, duties, CESS, OCTROI and other levies, insurance liabilities and all other obligations set out or implied in the contract for completion of work except otherwise specified in Bill of Quantities
- 6.1.2. The Contractor shall plan his works keeping in view restriction of approach and availability of space and time.
- 6.1.3. The area in which the work lies is mostly plain terrain.

## **6.2. DESIGN CRITERIA:**

- 6.2.1. The shop drawings should cover all the items pertaining to all temporary works required for fabrication, shop assembling, transportation scheme for various structural elements. The Contractor shall himself formulate a practical and viable scheme for fabrication of all structural members and launching scheme. The tenderer should, along with the tender specify the scheme that he proposes to adopt for carrying out all the works including fabricating &, transporting the same to site and Launching scheme.

## **6.3. REFERENCE TO THE STANDARD CODES OF PRACTICE:**

- 6.3.1 The contractor shall make available at site all relevant Indian Standard Codes of practice as applicable and other relevant British/German/American Standard.
- 6.3.2 Wherever Indian Standards do not cover some particular aspects of design/construction, relevant British/German/American Standards will be referred to.
- 6.3.3. In case of discrepancy among Standard codes of practice TECHNICAL Specifications and provision in sub-clauses in this NIT, the order of precedence will be as below:
- i. Provision in N.I.T.
  - ii. Technical Specifications
  - iii. IS 800 -2007
  - iv. Standard Codes of Practice



Bharat Heavy Electricals Limited  
Boiler Auxilaries Plant,  
Ranipet –632 406  
Civil Projects & Services

- v. In case of discrepancy among Standard Codes of Practice, the decision of the

Engineer in charge will be final.

#### **6.4 FABRICATION DEPOT:**

Contractor shall use his own premises / workshop for fabrication of structural steel work.

#### **6.5. ASSOCIATED WORKS:**

Works to be performed shall also include all general work preparatory to the fabrication of structural steel work, launching of steel structures during the works of any time necessary for the due and satisfactory construction completion and maintenance of the works to the intent and meaning of the drawings adopted and technical specifications, to best Engineering standards and orders that may be issued by the Engineer in charge from time to time, compliance by the agency with all Conditions of Contract, supply of all materials, apparatus, plants, equipment, transport, offices, stores, workshop, staff, labour and the provision of proper and sufficient protective works, temporary fencing, lighting and watching required for the safety of the public and protection of works on adjoining land, first-aid equipment, sanitary accommodation for the staff and workmen, effecting and maintenance of all insurances, the payment of all wages, salaries, provident fund, fees, royalties, duties or the other charges arising out of the fabrication of works and the regular clearance of rubbish, clearing up, leaving the site perfect and tidy on completion.

#### **6.6. PRELIMINARY DRAWINGS:**

Preliminary drawings in tender documents represent Employer's proposal based on preliminary design. Detailed working drawings will be submitted by the contractor based on the approval of structural design by the Engineer in charge.

#### **6.7. TIME SCHEDULE:**

The agency shall submit with the tender "Time Schedule" for completion of various portions of works. This schedule is to be within the overall completion period of 5 months (Five months) for the fabrication, supply and erection of structural steel work. The detailed programme in the form of a quantified bar chart or CPM network shall include all activities from start to completion.



## **SECTION – B**

### **SCOPE OF WORK**

#### **1.0 GENERAL:**

The scope of work for Pre-Engineered Steel Building System is as defined in the following sections under the contract which includes design, manufacture, supply and erection of Structural Steel System, Metal Roof System, Wall System, Trims and Flashings, Turbo Ventilators and all accessories as required for the successful and satisfactory completion of the contract.

#### **DETAILED SCOPE OF WORK:**

##### **1.1. Building components**

- Metal roof sheets,
- Side sheeting, purlins, sag rods cleats ,bolts and nuts,
- Roof Ventilators (Turbine) 112 nos per building,
- Translucent sheets for light (Poly carbonate),
- Purlins spacing based on load and deflection limits ,
- eaves strut
- Steel Portal Frames including Crane leg/stepped column,
- Rafter bracings,
- Column bracings (Portal Bracings @ 50 m c/c at 2 places),
- Gable end sheeting, purlin, columns,
- Gutters, calculation to be shown to justify the size,
- Down take pipes, calculation to be shown to justify the size,
- Crane girders EOT, legs connections, bolts to roof Leg and Crane leg,
- Semi gantry girders including brackets (2Nos/each column). Girders for the full length of the bay on one side of the bay.
- Buffer stop (Design Refer Annexure) 4 nos. in Rolling bay, 6 Nos. in Fabrication bay.
- Stair case to approach crane 1 no./building.
- Crane walk way and Hand Rails on both sides with toe plate and 5mm chequered plates, on both sides of the bay.
- Sliding doors 4 nos.5mx6m,
- Louvers for full length of the building,
- Foundation Bolts as per design.
- Connecting bolts (high strength),
- Framed openings for sliding door 4 Nos.



- Canopy for openings 4Nos.per building 3m cantilever with ends closed.
- Base plates with Gussets for stiffening as per design.
- Roof monitor for the entire length of the building with curved sheets and vertical FRP sheets as per drawing.
- Flashings

- 1.2. Testing of all materials and quality control as per quality plan.
- 1.3. Erection of all the components mentioned in the scope of work.
- 1.4. Load test on crane girders (after crane erection).

All aspects of quality assurance, including procurement & testing of materials and other components of the work, as specified or as directed:

- a. Clearing of site and handing over of all the works, as directed,
- b. Maintenance of the completed work during the maintenance period,
- c. Submission of completion (i.e., 'as-built') drawings and other related documents as specified:

Any other requirement for the commissioning of the buildings in all respects in accordance with the provisions of the Contractor and/or to ensure the structural stability and safety during and after construction

## 2.0 **DETAILED ENGINEERING:**

- 2.1 The contractor shall design the structures and prepare all the required drawings needed for correct and accurate construction. The design shall be strictly in accordance with the "Design Specifications" given in **Section - C** and building description given in **Section-B**.
- 2.2 The contractor shall submit the design basis and General Arrangement (G.A) of the structure along with required explanatory sketches/drawings and get the same reviewed by consultants / customer BHEL before starting the final design and Ready for Construction (RFC) drawings. Ten days time will be required by Consultants/BHEL for approval. The contractor shall also furnish the foundation loading, base reaction and all other relevant data for the structure to BHEL both soft and hard copy.
- 2.3 Construction of the structure shall not be taken up at site till all the drawings are reviewed by BHEL and comments/suggestions given by consultants/BHEL are incorporated.
- 2.4 BHEL reserves the right to review any/all or none of the designs and drawings. Review by BHEL shall not relieve the contractor of his responsibility for correct design and execution of the works.
- 2.5 The final design and RFC drawings shall directly adhere to the reviewed design basis and general arrangement and shall incorporate all the comments / suggestions given by BHEL without any extra cost to the Owner and any implication on time schedule for completion of work.



Bharat Heavy Electricals Limited  
Boiler Auxiliaries Plant,  
Ranipet –632 406  
Civil Projects & Services

2.6 After the completion of erection and construction, the contractor shall submit to the Owner “As Built” drawings in 3 sets of copies as specified elsewhere.

**3.0 CONSTRUCTION :**

- 3.1 Erection of all structural works, roofing, cladding, framed openings etc., including supply of all materials, labour, supervision, plant, tools and tackles etc., shall be carried out by the Contractor.
- 3.2 All materials and construction shall conform to the Material and Painting Specifications given in **Section –F** of this document.
- 3.3 Erection of Pre-Engineered Building shall be done in the presence / guidance of PEB Manufacturing experts.
- 3.4 Foundation Bolts shall be fixed and grouted by the civil contractor. The alignment and levels are to be checked and certified by the PEB Manufacturer’s Engineer.
- 3.5 No welding is permitted at site unless otherwise cleared by the Consultant/BHEL.



Bharat Heavy Electricals Limited  
Boiler Auxiliaries Plant,  
Ranipet –632 406  
Civil Projects & Services

## **SECTION –C**

### **BUILDING DESCRIPTION**

1.0 The brief building description for various areas of Proposed Project are as below:

#### **ROLLING BAY:**

- |                     |                                   |
|---------------------|-----------------------------------|
| a. Span             | : 29.5 Inner to inner of roof leg |
| b. Length           | : 210 c/c of column               |
| c. Clear height     | : 12.60 clear at Knee             |
| d. Crane (EOT) Span | : 28.5m Rail to Rail distance.    |

01. Roof Slope: 1:10

02. Bay spacing: 28 bays @7.5 m c/c. (Alternate can be suggested if economical)

03. No expansion joint is to be provided instead two no. of Longitudinal portal bracing to be provided at a spacing of 50m as specified in IS-800-2007

04. Roof: 0.47mm TCT Standing seam profile Bare galvalume sheets for the Roof Single skin.

05. Wall cladding: 0.5mm TCT Colour coated Galvalume sheet for the walls above 3.6m brick wall Single skin (Trapezoidal profile).

06. No louver.

07. Framed openings: 4 per side – 5m X6m height,

08. Canopies for openings: 4 nos. – 3m Projection with end closing and curved eaves,

09. Cranes: 20 MT - 3 No.

10. Crane Rail supply and fixing: By Crane Manufactures.

11. Crane columns and Gantry girder supply : By PEP manufacturers

12. Opal white -2mm Poly carbonate sheets for sky lights: 5% of Roof Plan Area.

13. Sliding door 4 Nos. 5mX6M (one side covered with colour coated galvalume same as wall sheet).

14. Roof Monitor 2.5 m x 1.5 m with crimped trapezoidal bare galvalume sheets and FRP Sheets on both the sides.

15. Eaves Gutter & Down take pipes: in Colour galvalume sheets.

16. Turbine ventilators 112 Nos.

**NOTE :** All frames shall be designed for future expansion as given in the above specifications and general arrangement drawings.



2.0 The brief building description for various areas of Proposed Project are as below:

### **FABRICATION BAY**

- a. Span : 29.5 Inner to inner of roof leg
  - b. Length : 210 c/c of column (approximate) 14 x 7.50m + 17 x 6.175m
  - c. Clear height : 13.60 clear at Knee
  - d. Crane (EOT) Span : 28.5m Rail to Rail distance.
1. Roof Slope: 1:10
  2. Bay spacing: 14 bays @ 7.5 m c/c + 17 bays of 6.175m. (100t crane area)
  3. No expansion joint is to be provided instead two no. of Longitudinal portal bracing to be provided at a spacing of 50m as specified in IS-800-2007
  4. Roof : 0.47mm TCT Standing seam profile Bare galvalume clip-on profile sheets for the Roof Single skin.
  5. Wall cladding: 0.5mm TCT Colour coated Galvalume sheet for the walls above 3.6m brick wall Single skin (Trapezoidal profile).
  6. Framed openings: 4 per side – 5X6 height.
  7. Canopies : 4 nos – 3m Projection with curved eave and end closing.
  8. Cranes: 100 MT 1 No and 20 MT 1 No.
  9. Crane Rail supply and fixing: By Crane Manufacturers.
  10. Crane columns and Gantry girder supply : By PEP manufacturers
  11. Opal white-2mm Poly carbonate sheets for sky lights: 5% of Roof Plan Area.
  12. Sliding door 4 Nos. 5mX6m (one side covered with colour coated galvalume same as wall sheet).
  13. Triangular louvers 0.60 x 1.00 – 2 Nos. for the full length of the building on both sides.
  14. Roof Monitor 2.5 m x 1.5 m with crimped trapezoidal bare galvalume sheets and FRP Sheets on both the sides
  15. Eaves Gutter & Down spouts: IN Colour galvalume sheets
  16. Turbine ventilators 112 Nos.

### **NOTE :**

All frames shall be designed for future expansion as given in the above specifications and general arrangement drawings.



## SECTION – D

### DESIGN SPECIFICATIONS

#### 1.0 **GENERAL** :

The design considerations given hereunder establish the minimum basic requirements for the design. However, structure shall be designed for the satisfactory performance of the functions for which the same is to be constructed.

- 1.1 Whenever any reference to IS Code is made, the same shall be taken as the latest revision (with all amendments issued there to- ) on the notified date of submission of tender .**For this work IS 800-2007 to be followed.**
- 1.2 Apart from the IS Codes mentioned in particular for wind, live and earthquake loads in the various clauses of this specifications, all other relevant codes such as American standards (AISC, MBMA, AISI & AWS specifications) related to the specific job under consideration and / or referred to in the above mentioned codes may be followed wherever applicable, if the specifications for the same are not available in the relevant IS codes.
- 1.3 In case of any variation / contradiction between the provisions of Codes and the specifications given hereunder, the provisions given in these specifications shall be followed.

#### 2.0 **LOADING**

##### 2.1 **General**

The structure shall be designed for all loads, including the weight of structure, live load, wind or earthquake. Due consideration shall be given to loading during the construction/erection phase and accounted for in the design. The design to be cater for the proposed future expansion also.

##### 2.2 **Design Loads:**

###### 2.2.1 **Dead Load :**

Self Weight of Structure including Purlins, Sheeting, Girts Bracings weight of turbo ventilators to be added as Dead load. etc.

###### 2.2.2 **Imposed Load (Live Loads)**

Live loads shall be as per IS – 875. For sloped roofs up to 10 deg. it shall be 0.75 KN/M<sup>2</sup>.

###### 2.2.3 **Wind Load :**

Wind loads shall be as per IS : 875.

The basic wind speed of the site is taken as 39 m/s

Values of coefficients  $K_1$ ,  $K_2$ ,  $K_3$  shall be as  $K_1 = 1.0$  for permanent structures.  $K_3 = 1.0$ ,  $K_2$  shall be taken for relevant class of the structure with Category 2 terrain with respect to the actual height of the structure. **The design life span of all structures shall be taken as 50 years.**



#### 2.2.4 Earthquake Load :

Seismic forces shall be as per IS:1893,ZONE III as applicable to Ranipet.

#### 3.0 VERTICAL DEFLECTION AND HORIZONTAL SWAY LIMITS :

a) Limiting Deflection : The limiting permissible vertical deflection for structural steel members shall be as specified below :

- Structures / structural components :as per IS 800 2007 code.

b) The limiting permissible horizontal deflection for as per IS 800 2007 code where 'h' is height of building at eaves,

#### 4.0. FRAME ANALYSIS :

The frame shall be analyzed with fixed base, suitable for future expansion along end walls, as given in the general arrangement drawings and specifications.

#### 5.0 DESIGN CHECK :

The design calculation should be checked by third party institution like IIT/Chennai. BHEL, RANIPET may submit the same set of document to another third party institution of their choice and get the approval. Comments/corrections by the third party consultant should be incorporated in the drawing and executed at site at no extra cost to BHEL, RANIPET. It shall be the responsibility of the firm to ensure structural stability of the building. The total design of the building shall be done to meet the design parameters given in design or technical specifications.

01. Loads as per clause 3.2 of IS -800 -2007 and IS -875

Design as per IS-800-2007.

Loading combinations as per Clause 3.5 and Table-4 IS-800-2007.

Deflection both lateral & Vertical as per Table 6 – IS-800-2007.

Design should be based on Limit State method.

02. Both Limit States of strength as well as serviceability should satisfy the performance requirements refer Clause 5.2.2.1 and 5.2.2.2 of IS-800-2007.

Factors governing the ultimate strength as per clause 5.5. of IS-800-2007 should be ensured.

Limit states of serviceability as per clause 5.6 of IS -800-2007 should be ensured.

Method of analysis may any one of the method prescribed as per clause 4.1 of IS-800-2007.

Notional Horizontal loads as applicable as per clause 4.3.6 should be applied on the structure and checked.

If Elastic analysis is carried out it should be based on 4.4 of IS -800-2007.



Effective length of comparison member should be as per clause 7.2 and maximum values of effective slenderness ratios should be as per Table 3 of IS-800-2007.

Limiting width to thickness ratio of elements may be as per Table 2 of IS-800-2007.

Transfer of Horizontal forces due to wind and EQ to the foundation should be ensured by proper means. Uplift due to wind and EQ should also be checked for beams and columns, purlins.

Expansion joint need not be given as per clause 3.10.3.2 of IS-800-2007 but longitudinal bracing 2 Nos. @ 50m to be provided (Ref. Fig.4).

Columns should be treated as fixed at foundation level.

Erection loads to be taken in design.

For bolts nuts and washers reference to be made to clause 2.4 of IS-800-2007.

Effective sectional area should be as per clause 7.3.2.

Gusseted column bases should be as per clause 7.4.2.

In the design laterally supported beams reference should be made to clause 8.3.4

Combined stresses refer clause 9.3 of IS-800-2007.

**The Design of Crane Girder should account for the following:**

01. Impact Factor 25%.
02. Limiting deflection as per IS-800-2007.
03. Minimum thickness of web refer clause 8.6.
04. Crane Girder to be designed for Tandem operation of 3nos of 20T EOT and 2nos of 3T SEMI GANTRY IN ROLLING BAY ONLY.
05. Buffer stop to be designed for Energy absorption.
06. Knee braces from the crane girder to the crane run way columns are not recommended.
07. Crane runway girders are to be designed as simply supported direct interconnection that would restrain relative rotation between adjacent ends of successive girders is not recommended.
08. Crane runway girders shall be designed and detailed and fabricated to resist fatigue damage
09. Crane runway girders need not have bottom flanges stiffened by means of a bracing system connected to an adjacent girders or stiffening truss.
10. Intermediate stiffeners shall be welded to the top flange with a full penetration (beveled) weld and should be stopped short of bottom flange. The end bearing stiffness should be welded to the top and bottom flange with a full penetration (beveled) weld. Alternatively end bearing stiffness may be welded to the bottom flange to obtain full bearing.



Bharat Heavy Electricals Limited  
Boiler Auxilaries Plant,  
Ranipet –632 406  
Civil Projects & Services

11. All welds between stiffeners and web plates or flange plates are to be continuous weld.

12. Brackets should not be used to support crane runway girders.

13. Web plate and Flange plate splice welds shall be 100% inspected by radiographic or ultrasonic inspection. Where flange to web welds are complete penetration welds they should be 100% inspected by ultrasonic inspection. Where flange to web welds are fillet welds they should be 100% inspected by liquid penetrant or magnetic particle inspection.

14. In the design of crane girder web it is to be noted that tension field design introduced into the AISC specification in 1961 is not permitted for crane runway girders.

Design and detailing for earthquake loads should be as per section 12.

For Fatigue resistance design for Crane graders etc. refer section 13.

For durability refer section 15.

#### **6.0 APPLICABLE CODES:**

**IS - 875 PART 1 TO 5**

**IS 1893- 2002**

**IS 800-2007**

**IS 801 -1975**

**IS 807 -2006**

END OF SECTION



Bharat Heavy Electricals Limited  
Boiler Auxiliaries Plant,  
Ranipet –632 406  
Civil Projects & Services

## **E- PARTICULAR SPECIFICATIONS**

### **1.0. STEEL STRUCTURES:**

- 1.1. This section covers the general requirements of designing, preparing necessary drawings, and providing, fabricating, painting, transporting, erecting, fixing in position Structural steel work for buildings, including all necessary temporary works and conducting of associated tests.
- 1.2. Contractor shall ensure that the Technical specifications detailed herein are carefully read and understood in conjunction with, and related to BILL of quantities, and the contractor in his rates includes all requirements defined herein and in other parts of the Contract Document. Works to be performed shall also include all general works preparatory to the fabrication of structural steel work, launching of steel structures during the works of any kind

### **1.3. APPLICABLE CODES AND STANDARDS:**

The codes and standards generally applicable to the work of this section are listed below. Latest revisions of the codes shall only be applicable.

IS-875 Part I:Code of Practice for Design Dead Loads for Building and Structures

IS-875 Part I:Code of Practice for Design Dead Loads for Building and Structures

IS-875 Part II:Code of Practice for Design Imposed Loads for Building and Structures

IS-875 Part III:Code of Practice for Design Wind Loads for Building and Structures

IS-1893 (2002): Criteria for Earth Quake Resistance Design Structures

IS-800 (2007):Code of Practice for General Construction in Steel. And all the codes listed in annex-A of the code

IS-801 (1975)::Code of Practice for use of Cold-Formed Light Gauge Steel Structure

IS-807 (2006)::Design, Erection & Testing (Structural Portion) of Cranes and Hoists – Code of Practice.

IS-816 (1969): Code of Practice for use of Metal Arc Welding for General Construction.

IS: 102 Ready mixed paint, brushing, red lead non-setting, priming

IS: 104 Ready mixed paint, brushing, zinc-chrome, priming.

IS: 800 Code of Practice for General Construction in Steel

IS: 801 Code of Practice for use of Cold Formed Light Gauge Steel Structural Members in General Building Construction.

IS: 806 Code of Practice for use of Steel Tubes in General Building Construction.

IS: 808 Dimensions of Hot Rolled Steel Beam, channel and angle sections



Bharat Heavy Electricals Limited  
Boiler Auxiliaries Plant,  
Ranipet –632 406  
Civil Projects & Services

- IS:811 Cold Formed Light Gauge Structural Steel Sections.
- IS:813 Scheme of Symbols for Welding
- IS:814 Covered Electrodes for Manual Metal Arc Welding of Carbon and Carbon-Manganese Steel
- IS:816 Code of Practice of use of Metal Arc Welding for General construction in Mild Steel.
- IS:818 Code of Practice for Safety and Health requirements in electric and Gas Welding and Cutting operations.
- IS:822 Code of Procedure for Inspection of welds.
- IS:875 Code of Practice for Structural Safety of Building, Loading Standards
- IS:1024 Code of Practice for use of welding in Bridges and Structures Subject to Dynamic Loading.
- IS:1120 Coach Screws
- IS:1161 Steel Tubes for Structural Purposes
- IS:1182 Recommended practice for Radiographic Examination of Fusion Welded butt Joints in Steel plates.
- IS:1363 Hexagon Head Bolts, Screws and Nuts (Grades–C)
- IS:1364 Hexagon Head Bolts, Screws and Nuts (Grades A&B)
- IS:1365 Slotted Counter-sunk Head Screws
- IS:1367 Technical Supply condition for threaded fasteners.
- IS:1852 Rolling and Cutting Tolerances for Hot Rolled Steel Products.
- IS:1977 Low Tensile Structural Steel
- IS:2016 Plain washers
- IS:2062 Steel for General Structural Purposes
- IS:2074 Ready Mixed Paint, Air drying, Red Oxide-Zinc chrome priming.
- IS:3063 Fasteners-Single Coil Rectangular Section Spring Washers
- IS:3443 Crane Rail Sections
- IS:3600 Testing methods of fusion welded joints and weld metal in steel.
- IS:3613 Acceptance tests for wire flux combination for submerged, arc welding.
- IS:3757 High strength structural bolts.
- IS:4000 Code of practice for high strength bolts in steel structures
- IS:4923 Hollow Steel sections for structural use.
- IS:5369 General Requirements for plain washers and lock washers
- IS:5624 Foundation bolts.



IS:6227 Code, of practice for use of metal arc welding in tubular structures

IS:6623 High strength structural nuts.

IS:6639 Hexagonal bolts for steel structures.

IS:8500 Structural Steel Micro-alloyed (Medium and high strength qualities)

#### **1.4 DESIGN:**

1.4.1 The contractor will be required to carry out detailed design of the structures, prepare engineering drawings and detailed 'shop drawings', get these approved from Engineer, and then carry out the fabrication work based on approved drawings.

1.4.2 Contractor's designs shall, unless otherwise specified, be based on provisions of relevant BIS codes. Design guideline and design parameters are mentioned in **SECTION –C** to these specifications.

Where corresponding parameters mentioned in BIS codes are different from those mentioned in **SECTION C** the latter shall take precedence.

1.4.3 Contractor's designs shall be based on general descriptions of buildings given in SECTION -B to these specifications, and those shown in tender drawings Where information given in SECTION-B do not tally with the tender drawings, information given in tender drawings shall take precedence.

1.4.4 Where codes and standards listed in clause 1.3 do not cover the requirements of design, only in those cases the contractor may refer to other international standards of design, However such references should be made only with the approval of the Engineer in charge.

1.4.5 Contractor shall submit his design calculations and 'Engineering Drawings' along with proof design to the Engineer in charge for his approval. The contractor is advised to discuss his design philosophy and design procedure with the Engineer in charge before proceeding with the final design work.

1.4.6 It shall be the responsibility of the contractor to obtain all relevant design information from the Engineer in charge for preparing his design, and other utility services supported by the structure.

#### **1.5 DRAWINGS:**

1.5.1 Tender Drawings shall be the 'Basic' drawings for developing design drawings. Design drawings shall then be developed in to final 'Shop Drawings' to be prepared by the contractor. For preparing shop drawings, the contractor shall obtain written approval from the Engineer in charge.

1.5.2 Tender drawings furnished to the contractor shall form a part of these specifications. The contractor shall consult these in detail for all the information contained therein, which pertains to and is required for his work.



Bharat Heavy Electricals Limited  
Boiler Auxilaries Plant,  
Ranipet –632 406  
Civil Projects & Services

- 1.5.3 Revisions to drawings, even after release for preparation of shop drawings, are likely to be made to reflect additional data, or, additional details defining updated requirements. Revisions to drawings and any new drawings made to include additional work for the Contractor shall be considered a part of this specification and contract. Extra claims by the contractor on this account shall not be entertained.
- 1.5.4 Tender drawings show all relevant dimensions, and if necessary, clearances of structures, special loading where necessary, general location of openings at various levels and all other information required to enable the contractor to prepare drawings for general engineering / fabrication and erection.
- 1.5.5 It shall be clearly understood that the Tender drawings are only informative drawings and are not intended to show exact and final information or specific connection details.
- 1.5.6 In case of variations in 'Drawings' and 'Specifications', the decision of the Engineer in charge shall be final and binding. Should the Contractor during the execution of his work, find discrepancies in the information furnished to him, he shall refer such discrepancies to the Engineer in charge before proceeding with such work.
- 1.5.7 Contractor shall prepare all fabrication and erection drawings necessary for completing the work satisfactorily.
- 1.5.8 Drawings shall be of one standard size, and shall be clear and legible. Drawings shall be based on Tender drawings supplied to the contractor, but he shall verify actual clearances and dimensions from site on works executed by other agencies and from Engineer in charge.
- 1.5.9 Shop drawings shall include, but not be limited to:-
  - A. Detailed marking plans.
  - B. Details member connections and connections to other structures and components of building.
  - C. Detailed dimensions for fabrication indicating dimensional modifications required for field conditions
  - D. Welding and bolting procedures to be used both at shop and field.
  - E. Cambers required to be provided, and permissible tolerances in fabrication.
  - F. Assembly and Erection sequences indicating components to be connected at field.
  - G. Complete bill of materials for each component (preferably drawing wise.)
- 1.5.10 Before submitting of shop drawings and calculations to the Engineer in-charge for his approval, these shall be checked and certified by the contractors own structural Engineer. Till such time shop detail of a component is approved. Fabrication work for the component shall not be started.



Bharat Heavy Electricals Limited  
Boiler Auxiliaries Plant,  
Ranipet –632 406  
Civil Projects & Services

- 1.5.11 If necessary and called for by the Engineer, shop drawings shall be revised to suit modified requirements and these shall be resubmitted for approval of the Engineer in charge.
- 1.5.12 While the shop drawings prepared by the contractor, and approved by the Engineer in charge represent the correct interpretation of work to be done, the contractor is not relieved of his responsibilities for:-
- a) Dimensional accuracy
  - b) Correctness of engineering and design of connections
  - c) Fit of parts
  - d) Details
  - e) Errors or omissions
  - f) Material and workmanship
  - g) Methodology of fabrication and erection
  - h) Safety of performance



Bharat Heavy Electricals Limited  
Boiler Auxilaries Plant,  
Ranipet –632 406  
Civil Projects & Services

## **1.6 . SUBMITTALS:**

- 1.6.1 On commencement of the Project, the Contractor shall submit the following to the Engineer in charge:-
- A. Prior to the technical submittals, the contractor shall submit detailed baseline program and methodology indicating the proposed overall schedule for documentation such as calculations, shop/working drawings, plan/procedures and records. Submission of samples, process of fabrication / delivery to site storage yard for the approval of the Engineer in charge.
  - B. Complete fabrication drawings, materials lists, cutting lists, bolt lists, welding schedules and QC schedules, based on the design drawing furnished to him and in accordance with the approved schedule. It is highlighted that structural steel members, dimensions thereof indicated in tender drawings are tentative only, and may be modified during final design stage.
  - C. Results of any tests, as and when conducted and as required by the Engineer in charge.
  - D. Manufacturer's mill test reports in respect of steel materials, bolts, nuts and electrodes, wires as may be applicable.
  - E. A detailed list of all constructional Plant & Equipment, such as cranes, derricks, winches, welding sets etc. their makes, model, present condition and location, available to the contractor and the ones he will employ on the job to maintain the progress of work in accordance with the contract.
  - F. The total number of experienced personnel of each category, like fitters, welders, riggers etc., which he intends to deploy on the project.
  - G. The contractor shall submit complete design calculations for any alternative sections proposed by him for approval of the Engineer in charge. Use of any alternative section shall be subject to approval of the Engineer in charge. However, no extra payment will be entertained on account of this except as specified in schedule of quantities.

## **1.7 MATERIALS :**

### **1.7.1 STEEL SUPPLIED BY THE CONTRACTOR:**

- 1.7.1.1 The Contractor shall furnish to the Engineer in charge all mill orders covering the material ordered by him for this work and also the test reports received from the Mills for his approval and information. It is not intended that all the steel materials to be supplied by the Contractor for the work shall be specially purchased from the rolling mills. The Contractor's stock material may be used, provided the mill test reports identified with the materials, satisfactorily demonstrate the specified grade and quality. The



Bharat Heavy Electricals Limited  
Boiler Auxiliaries Plant,  
Ranipet –632 406  
Civil Projects & Services

Engineer in charge shall have the right to test random samples to prove authenticity of the test certificates produced by the Contractor, at the Contractor's cost.

- 1.7.1.2 All steel materials supplied by the Contractor shall be in a sound condition, of recent manufacture, free from defects, loose mill scale, slag intrusions, laminations, pitting, flaky rust, etc. and be of full weight and thickness specified.
- 1.7.1.3 Wherever the Contractor, in order to accommodate his other materials in stock, desires to substitute structural steels or plates for the sizes shown on drawings, such substitutions shall be made only after authorization in writing by the Engineer in charge.
- 1.7.1.4 The Engineer in charge may direct that substitution be made, when he considers such substitution is necessary.

**1.7.2 HANDLING AND STORAGE:**

- 1.7.2.1 Proper storage of steel (sections and fabricated members) at the job site shall be the responsibility of the Contractor.
- 1.7.2.2 Structural steel shall be stored out of mud and dirt. Proper drainage of the storage area shall be provided. These shall be protected from damage or soiling by adjacent construction operations.
- 1.7.2.3 Fabricated steel shall not be handled until the paint has thoroughly dried. Care shall be taken to avoid paint abrasions and other damage. Teel work shall be transported in such a way so as not to over stress the fabricated sections. All pieces bent or otherwise damaged shall be rejected and shall be replaced by the contractor at his own cost.
- 1.7.2.4 Checking and inspection of fabricated structural steel work by the Engineer in charge shall be done at various stages of completion of fabrication work. The contractor is required to ensure that fabricated steel work is properly stacked such that all joints of all members are either visible or accessible for inspection at all stages of inspection work. Care should also be taken to ensure that fabricated members are not subjected to stresses due to defective stacking.

**1.7.3 FABRICATION:**

- 1.7.3.1 All fabrication work shall be done in accordance with IS: 800: 2007 read in conjunction with relevant codes mentioned therein.
- 1.7.3.2 Fabrication shall be done in workshops approved by Engineer in charge, unless specifically permitted by Engineer in charge that fabrication can be done at site. Under such circumstances work shall be done on a specially designed and constructed platform. Location, size, specification and construction of such a platform shall have prior approval of Engineer in charge. Loads associated with such platforms shall be provided to Engineer in charge.



- 1.7.3.3 Mild steel rolled sections and plates shall be cut by shearing/machining and grinding the surfaces to true sizes and shapes. Gas cutting of mild steel may be permitted by the Engineer in charge, provided that every cut face and edge is smoothed by grinding operation. Prior approval of Engineer in charge must be obtained for using gas-cutting techniques either by mechanized gas cutters or manually operated gas cutters. While, using gas-cutting methods, proper allowance must be made for grinding to bring the cut piece to exact required dimensions.
- 1.7.3.4 Extensive use of templates shall be made in doing fabrication work. Templates shall be clean and should have true surfaces prepared for every successive use. Reinforcements for the structural steel members if required shall be included. In case actual members are used as templates for similar pieces are fit to be incorporated in the finished structure. Jigs and manipulators shall be used, where practicable, and shall be designed to facilitate welding and to ensure that all welds are easily accessible to the operators.
- 1.7.3.5 All material shall be straight and free from twist and bends unless required to be curvilinear in form. If necessary the material shall be straightened and / or flattened/straightened by pressure. Heating of rolled sections and plates for purpose of straightening shall not be permitted.
- 1.7.3.6 Curvilinear members shall be formed by bending with the help of pneumatic press. Final shaping, to a very limited extent, however, may be done by local heat application. This shall be done only on receiving approval from the Engineer in charge.

#### **1.7.4 HOLING:**

- 1.7.4.1 All holes shall be made at right angles to the surface of the member. Holes shall be clean cut without any torn or jagged edges. Holes shall be done by drilling. Punching shall not be resorted to, unless previously approved by the Engineer. In any case, punching of holes in materials having a thickness in excess of the connector diameter, or, for materials thicker than 16mm, the hole shall be punched 3mm less in diameter than the required size and then reamed to the full size. Holes shall not be formed or enlarged by burning or gas cutting under any circumstances.

#### **1.7.5 WELDING:**

##### **1.7.5.1 GENERAL:**

In general only Automatic submerged arc welding will be used for fabrication. Subject to approval of Engineer in charge, Metal inert gas welding may be done for short length where access to the location of the weld does not permit submerged arc welding. The welding and the welded work shall conform to IS:816, unless otherwise specified. As much work as possible shall be welded in shops and the layout and sequence of operations shall be so arranged as to eliminate distortion and shrinkage stresses. Unless otherwise specified all weld shall be for full contact for all sides.



- 1.7.5.2 Electrodes for shielded-arc manual welds shall comply with the requirements of IS: 814 and shall be amenable to radiographic tests and shall be of approved make. The electrodes for manual arc welding shall be suitable for use in the position and type of work, as laid down in the above specifications and as recommended by the manufacturers. Electrodes classification group 1 or 2 as given in IS: 814 shall be used for welding steel conforming to IS:2062. Electrodes shall conform to IS-1442 for steel conforming to IS: 8500. Joints in materials above 20mm thick, and, all important connections shall be made with low hydrogen electrodes. Electrode flux covering shall be sound and unbroken. Broken or damaged coating shall cause the electrodes to be discarded. Covered electrodes for manual arc-welding shall be properly stored in an oven prior to use in a manner recommended by the Manufacturer and only an hour's quota shall be issued to each welder from the oven.
- 1.7.5.3 Electrodes larger than 5mm diameter shall not be used for root-runs in butt-welds. Welding plant and accessories shall have capacity adequate for the welding procedure laid down and shall satisfy appropriate standards and be of approved make and quality, the Contractor shall maintain all welding plant in good working order. All the electrical plant in connection with the welding operation shall be properly and adequately earthed and adequate means of measuring the current shall be provided.
- All welds shall be made only by welders and welding operators who have been properly trained and previously qualified by tests to perform the type of work required as prescribed in the relevant applicable standards.
- All welds shall be free from defects like below holes, slag inclusions, lack of penetration, undercutting, cracks etc. All welds shall be cleaned of slag or flux and show uniform sections, smoothness of weld metal, feather edges without overlap and freedom from porosity.
- 1.7.5.4 Fusion faces and surfaces adjacent to the joint for a distance of at least 50mm on either side shall be absolutely free from grease, paint, loose scales, moisture or any other substance which might interfere with welding or adversely affect the quality of the weld. Joint surfaces shall be smooth, uniform and free from fins, tears, laminations etc. Preparation of fusion faces shall be done in accordance with the approved fabrication drawings by shearing, chipping, machining or machine flame cutting except that shearing shall not be used for thickness over 8mm.
- 1.7.5.5 In the fabrication of cover-plated beams and built up members all shop splices in each component part shall be made before such component part is welded to other parts of the member. Wherever weld reinforcement interferes with proper fit-up between components to be assembled for welding, these welds shall be ground flush prior to assembly.
- 1.7.5.6 Members to be joined by fillet welding shall be brought and held close together as possible and in no event shall be separated by more than 3mm. If the separation is 1.5mm or greater, the fillet weld size shall



Bharat Heavy Electricals Limited  
Boiler Auxiliaries Plant,  
Ranipet –632 406  
Civil Projects & Services

be increased by the amount of separation. This shall only apply in the case of continuous welds. The fit-up of joints at contact surfaces which are not completely sealed by welds shall be close enough to exclude water after painting.

- 1.7.5.7 The separation between fraying surfaces of lap joints and butt joints with backing plate shall not exceed 1.5mm. Abutting parts to be butt welded shall be carefully aligned and the correct root gap maintained throughout the welding operation. Misalignments greater than 25 percent of the thickness of the thinner plate or 3mm whichever is smaller shall be corrected and in making the correction the parts shall not be drawn into a slope sharper than 2 degree (1 in 27.5)
- 1.7.5.8 Welding procedures recommended by appropriate welding standards and known to provide satisfactory welds shall be followed. A welding procedure shall be prepared by the Contractor and submitted to the Engineer in charge for approval before start of welding.
- 1.7.5.9 Approval of the welding procedure by the Engineer in charge shall not relieve the Contractor of his responsibility for correct and sound welding without undue distortion in the finished structure.
- 1.7.5.10 Voltage and current (and polarity if direct current is used) shall be set according to the recommendations of the Manufacturer of the electrode being used, and suitable to thickness of material, joint form etc. The work shall be positioned for flat welding wherever practicable and overhead weld shall be avoided.
- 1.7.5.11 No Welding shall be done when the surface of the members is wet, not during periods of high wind unless the welding operator and the work are properly protected. In joints connected by fillet welds, the minimum sizes of single run fillet welds or first runs and minimum full sizes of fillet welds shall conform to the requirements of IS:816 and IS:823, Fillet welds larger than 8mm shall be made with two or more passes.
- 1.7.5.12 All 'full penetration butt welds' made by manual arc-welding, except when produced with the aid of backing material or welded in flat position, from both sides in square-edge material, not over 8mm thick with root opening not less than one-half the thickness of the thinner part joined, shall have the root of the initial layer gouged out on the back side before welding is started from that side, and shall be so welded as to secure sound metal and complete fusion throughout the entire cross section.
- 1.7.5.13 Butt welds shall be terminated at the ends of a joint in a manner that will ensure their soundness where abutting parts are 20mm or more in thickness, run-on and run-off plates with similar edge preparation end having a width not less than the thickness of the thicker part joined shall be used. These extension pieces shall be removed upon completion of the weld and the ends of the weld made smooth and flush with the abutting parts. Where the abutting parts are thinner than 20mm the extension pieces may be omitted but the ends of the butt welds shall then be chipped



or gouged out to sound metal and side welded to fill up the ends to the required reinforcement.

1.7.5.14 Each layer of a multiple layer weld except root and surface runs may be moderately peeled with light blows from a blunt tool. Care shall be exercised to prevent scaling or flaking of weld and base metal from over-peeling.

1.7.5.15 Before commencing fabricating of a member or structure in which welding is likely to result in distortion and/or locked up stresses, a complete programme of fabrication, assembly and welding shall be made and submitted to the Engineer in charge for his approval. Such a programme shall, include, besides other appropriate details, full particulars in regard to the following:-

- i) Proposed pre-bending of components such as flanges and presetting of joints to offset expected distortion.
- ii) Make up of sub-assemblies proposed to be welded before incorporation in final assembly.
- iii) Proposed joint forms, classification of wire and flux or covered electrodes, welding process including fitting and welding sequence with directions in which freedom of movement is to be allowed.
- iv) Proposed number, spacing and type of strong details of jigs and fixtures for maintaining proper fit up and alignment during welding.
- v) Any other special features like assembling similar members back to back or stress relief.

Suggestive minimum preheating of metals:-

Thickness of thickest part at point of welding	Minimum Preheat & Interpass Temperature			
	Other than low-hydrogen welding electrodes		Low Hydrogen welding electrodes	
Up to 20 mm incl.	IS:226 steel or IS: 2062 steel	IS: 961 steel	IS:226 steel or IS: 2062 steel	IS:961
	None	Welding with this process not	None	10 Dig C



		Allowed		
Over 20mm to 40 mm incl.	65° C		10° C	65° C
Over 40mm to 63 mm incl.	110° C		95° C	110° C
Over 63 mm.	150° C		110° C	150° C

Minimum pre heat temperature for metal thickness up to 50 mm shall be 10°C.

1.7.8.16 If so desired by the Engineer in charge, mock up welding shall be carried out at the contractor's cost to establish the efficacy of the proposed programme, with any modification suggested by the Engineer in charge in limiting distortion or/and residual stress to acceptable levels. Such modifications will not relieve the contractor of any of his responsibilities.

1.7.8.17 The ends of butt joints shall be welded so as to provide full throat thickness. This may be done by the use of extension pieces, cross-runs or other approved means. The weld face shall, at all places, be deposited projecting the surface of the parent metal. Where a flush surface is required, the surplus metal shall be dressed off. Splices and butt joints of compression members, depending on contact for stress transmission, shall be accurately machined over the whole section. In column bases, the ends of shafts together with the attached gussets, angles, channels etc., after bolting and/or welding together as the case may be, shall be accurately machined so that the parts connected butt over the entire surface of contact. Care shall be taken that connecting angles or channels are fixed with such accuracy that they are not reduced in thickness by machining by more than 0.80mm.

1.7.8.18 The minimum leg length of a fillet weld as deposited shall be not less than the specified size. In no case shall a concave weld be deposited, unless specifically permitted. Where permitted, the leg length shall be increased above that specified length, so that the resultant throat thickness is as great as would have been obtained by the deposition of a flat-faced weld of the specified leg length.

1.7.8.19 After making each run of welding, all slag shall be thoroughly removed and the surface cleaned. The weld metal, as deposited (including tack welds), shall be free from cracks, slag inclusions, porosity, cavities and other deposition faults. The weld metal shall be properly fused with the parent metal without under cutting or overlapping at the toes of the weld. The surface of the weld shall have a uniform consistent contour and regular appearance.

#### **1.7.9 INSPECTION OF WELDS:**

1.7.9.1 All welds shall be inspected for flaws by any of the methods described in these Specifications, and as per IS: 822. The choice of the method to be adopted, shall be determined by the Engineer in charge.

1.7.9.2 The contractor shall arrange for all tests as called for, at his own cost.



1.7.9.3 In case the tests uncover defective work, such tests shall be at the Contractor's cost and the Contractor shall correct such defects at his own cost and prove the soundness of rectified work.

1.7.9.4 The correction of defective welds shall be carried out as directed by the Engineer in charge without damaging the parent metal. When a crack in the weld is removed, magnetic particle inspection or any other equally positive means as prescribed by the Engineer in charge shall be used to ensure that the whole of the crack and material up to 25mm beyond each end of the crack has been removed. Cost of all such tests and operations incidental to correction shall be to the Contractor's account.

#### **1.7.10 FABRICATION TOLERANCES:**

1.7.10.1 Unless otherwise shown on drawings, the fabrication tolerances shall generally be as detailed hereunder.

#### **1.7.11 STRAIGHTNESS:**

1.7.11.1 The dimensional and weight tolerance for rolled shapes shall be in accordance with IS: 1852 for indigenous steel and equivalent applicable codes for imported steel. The acceptable limits for straightness (sweep and camber) for rolled or fabricated members shall be:-

Struts and columns: L/1000 or 10mm whichever is smaller. For all other members not primarily in compression such as purlins, beams, bracings & web members of trusses and latticed girders: L/500 or 15mm whichever is less. (Where L is the length of finished member, or such lesser length as the Engineer in charge may specify).

#### **1.7.12 TWISTS:**

1.7.12.1 A limit of twist (prior to erection) in:-

Box girders and heavy columns:	L/1500
Other members	L/1000

#### **1.7.13 CAMBER:**

1.7.13.1 Tolerance in specified camber of structural members shall be  $\pm 3$ mm.

#### **1.7.14 LENGTH:**

1.7.14.1 Tolerance in specified length shall be as follows:-

Type of member	Tolerance
A column finished for contact bearing	: $\pm 1$ mm
Other members (e.g. beams) under 10 m	: + 0 and -3mm
Other members (e.g. beams) 10 m long and over	: + 0 and -5mm



#### **1.7.15 SQUARE-NESS AT END OF MEMBERS:**

1.7.15.1.1 Beam to beam and beam to column connections where the abutting parts are to be jointed by butt welds, permissible deviation from the square-ness of the end is:-

Beams up to 600mm in depth: 1.5mm

Beams over 600mm in depth : 1.5mm every 600 mm depth up to a max of 3mm

1.7.15.1.2 Where abutting parts are to be jointed by bolting through cleats or end plates, the connections require closer tolerance.

Beams up to 600mm in depth: 1.0mm

Beams over 600mm in depth : max of 1.5mm

#### **1.7.16 BUTT JOINTS:**

For full bearing, two abutting ends of columns shall first be aligned to within 1 in 1000 of their combined length and then the following conditions shall be met:

(a) Over at least 80% of the bearing surface the clearance between the surfaces does not exceed 0.10mm.

(b) Over the remainder of the surfaces the clearance between the surfaces does not exceed 0.30mm.

Where web stiffeners are designed for full bearing on either the top flange or bottom flange or both, at least half the stiffener shall be in positive contact with the flange. The remainder of the contact face could have a max. gap of 0.25mm.

#### **1.7.17 DEPTH OF MEMBER:**

1.7.17.1 Acceptable deviation from the specified overall depth is:

For depths of 900 mm and under:  $\pm 3$ mm.

For depths over 900 mm and under 1800mm:  $\pm 5$ mm

For depths of 1800 mm and over: +8 mm: - 5mm

#### **1.7.18 WEB PLATES:**

1.7.18.1 Acceptable deviation from flatness in girder webs in the length between the stiffeners or in a length equal to the girder depth shall be  $1/150^{\text{th}}$  of the total web depth.

#### **1.7.19 FLANGE PLATES:**

1.7.19.1 Limit for combined warp-age and tilt on the flanges of a built up member is  $1/200$  of the total width of flange or 1.5 mm whichever is smaller measured with respect to centre line of flange.



1.7.19.2 Lateral deviation between centre line of web plate and centre line of flange plate at contact surfaces, in the case of built up sections shall not exceed 3 mm.

**1.7.20 INSPECTION:**

1.7.20.1 The contractor shall give due notice to the Engineer in charge in advance if the materials or workmanship getting ready for inspection.

1.7.20.2 All rejected material shall be promptly removed from the shop and replaced with new material for the Engineer in charge's approval / inspection. The fact that certain material has been accepted at the Contractor's shop shall not invalidate final rejection at site by the Engineer in charge, if it fails to be in proper conditioner has fabrication in accuracies which prevents proper assembly. No materials shall be painted or dispatched to site without inspection and approval by the Engineer in charge unless, such inspection is waived in writing by the Engineer in charge.

1.7.20.3 Shop inspection by the Engineer in charge or his authorized representative, or submission of test certificates and acceptance thereof by the Engineer, shall not relieve the Contractor from the responsibility of furnishing material conforming to the requirements of these specifications. Nor shall it invalidate any claim, which the Engineer in charge may make because of defective or unsatisfactory material and/or workmanship.

1.7.20.4 The Contractor shall provide all the testing and inspection services and facilities for shop work except where otherwise specified. For fabrication work carried out in the field, the same standard of supervision and quality control shall be maintained as in shop fabricated work. Inspection and testing shall be conducted in a manner satisfactory to the Engineer in charge.

1.7.20.5 **Column Fabrication Tolerances:** The work point at about the elevation of the crane girders seat shall not be vary more than  $\pm 1/8^{\text{th}}$  inch from the straight line struck between top and bottom points. The AWS straightness tolerances will control between the work points. The girder seat plates are to be located from the work centre line with a tolerance of  $\pm 1/32$  inch.

**1.7.20.6 Crane Runway Girder Fabrication tolerances:**

Crane Girders: Horizontal sweeps in crane runway girders shall not exceed  $1/4^{\text{th}}$  inch per 50 feet length of girder span. Camber shall not exceed  $\pm 1/4^{\text{th}}$  inch per 50 feet girder span over that indicated on the design drawing.

**Girder ends:** The ends of the girder supported by the columns, the bottom flange shall be flat and perpendicular to the web. The flatness tolerance shall be  $\pm 1/32$  inch at any point supported by the column cap plates.

**Girder Depth:** The depth of crane girder shall be detailed and fabricated to a "KEEP" at their ends of  $\pm 1/32$  inch by use of a variable thickness sole plate.



**Crane Girder alignment:** The centre line top of each crane girder at each column shall be aligned horizontally within  $\pm 1/4^{\text{th}}$  inch of the theoretical base lines both sides of the runway.

#### **1.7.21 TESTING:**

##### **1.7.21.1 MATERIAL TESTING:**

If mill test reports are not available for any steel materials, the same shall be got tested by the contractor to the satisfaction of Engineer in charge to demonstrate conformity with the relevant specification.

#### **1.7.22 TESTS ON WELDS:**

##### **1.7.22.1 MAGNETIC PARTICLE TEST:**

Only where the Engineer in charge requires that flaw-detection of welds be done by 'magnetic particle test', in such cases the tests are to be done in accordance with IS:3703. If heat treatment is performed, the completed weld shall be examined after the heat treatment. All defects shall be repaired and re-tested. Magnetic particle tests shall be carried out using alternating current. Direct current may be used with the explicit written permission of the Engineer in charge.

##### **1.7.23 DYE PENETRATION TEST:**

Where welds are required to be examined by dye penetration inspection method, such tests shall be carried out in accordance with IS:3658.

##### **1.7.24 RADIOGRAPHIC INSPECTION:**

Whether instructed by Engineer in charge, or not, all 'Butt' welds shall be inspected by radiographic examination method. Such examination shall be done in accordance with the recommendations of IS:1182.

##### **1.7.25 TEST FAILURE:**

At any stage, in the event of any material or work failing to meet an inspection of test requirement, which is not overseen by the Engineer in charge, the Contractor shall notify the Engineer in charge immediately. The contractor must obtain permission from Engineer in charge before repair is undertaken. The quality control procedures to be followed to ensure satisfactory repair shall be subject to approval by the Engineer in charge. The Engineer in charge has the right to specify additional inspection or testing as he deems necessary, and the additional cost of such testing shall be borne by the Contractor. The Contractor shall maintain records of all inspection and testing which shall be made available to the Engineer in charge on demand.

##### **1.7.26 SHOP MATCHING:**

Some steel work, particularly columns along with tie beams, bracings etc. may have to be shop assembled to ensure satisfactory fabrication, if the Engineer in charge so desires, he may order such assembly at shop for verification.



The Contractor shall comply with such instructions without claiming any extra cost.

**1.7.27 SHOP ASSEMBLY:**

1.7.27.1 Steel work shall be temporarily shop assembled, as necessary, so that the accuracy of fit may be checked before dispatch. The parts shall be shop assembled with a sufficient number of parallel drifts to bring and keep the parts in place.

1.7.27.2 Since parts drilled or punched, with templates having steel bushes shall be similar and, as such, interchangeable, such steel work may be shop erected in part only, as agreed by the Engineer in charge.

**1.7.28 ASSEMBLY:**

1.7.28.1 All parts assembled for bolting shall be in close contact over the whole surface.

1.7.28.2 The component parts shall be so assembled that they are neither twisted nor otherwise damaged, specified cambers, if any, shall be provided.

1.7.28.3 All parts of bolted and welded members shall be held firmly in position by means of jigs or clamps while bolting or welding. No drifting of holes shall be permitted, except to draw the parts together and no drift used shall be larger than the nominal diameter of the bolt. Drifting done during assembling shall not distort the metal or enlarge the holes.

1.7.28.4 Trial assemblies shall be carried out at the fabrication stage to ensure accuracy of workmanship, and these checks shall be witnessed by the Engineer in charge/Authorized inspecting agency. Such trial assembly shall be at the cost of the contractor.

**1.7.29 FIELD BOLTS:**

1. Requirements stipulated under bolting shall apply for field bolts also. Field bolts nuts and washers shall be furnished by the contractor in excess of the nominal numbers required. He shall supply the full number of bolts, nuts and washers and other necessary fittings required completing the work, together with the additional bolts, nuts and washers totaling to 10% of the requirement subject to minimum of 10 Nos.

2. At the time of assembly, the surfaces in contact shall be free of paint or any other applied finish, oil, dirt, loose rust, loose scale, burrs and other defects which would prevent solid seating or the parts or would interfere with the development of friction between them.

3. If any other surface condition, including a machined surface, is specified, it shall be the responsibility of the Contractor to work within the slip factor specified for the particular case.

4. Each bolt and nut shall be assembled with washers of appropriate shape, quality and number in cases where plane parallel surfaces are involved, such washers shall be placed under the bolt head or the nut, whichever is to be rotated during the tightening operation. The rotated nut or bolt head shall be



tightened against a surface normal to the bolt axis, and the appropriate tapered washer shall be used when the surfaces are not parallel. The angle between the bolt axis and the surface under the non-rotating component (i.e. the bolt head or the nut) shall be  $90+3$  degree. For angles outside these limits, a tapered washer shall be placed under the non-rotating component. Tapered washers shall be correctly positioned.

5. No gasket or other flexible material shall be placed between the holes. The holes in parts to be joined shall be sufficiently well aligned to permit bolts to be freely placed in position. Driving of bolts is not permitted. The nuts shall be placed so that the identification marks are clearly visible after tightening. Nut and bolts shall always be tightened in a staggered pattern and where there are more than four bolts in anyone joint, they shall be tightened from the centre of the joint outwards.
6. If after final tightening, a nut or bolt is slackened off for any reason, the bolt, nut and washer or washers shall be discarded and not used again.

#### **1.7.30 MARKING OF MEMBERS:**

- 1.7.30.1 After checking and inspection, all members shall be marked for identification during erection. This mark shall correspond to distinguishing marks on approved erection drawings and shall be legibly painted and stamped on it. The erection mark shall be stamped with a metal dye with figures at least 20mm high and to such optimum depth as to be clearly visible, even after a member is galvanized.
- 1.7.30.2 All erection marks shall be on the outer surface of all sections and near one end, but clear of bolt-holes. The marking shall be so stamped that they are easily discernible when sorting out members. The stamped marking shall be encircled boldly by a distinguishable paint to facilitate easy location. Erection marks on like pieces shall be at identical location. Members having lengths of 7.0m or more shall have the erection mark at both ends.
- 1.7.30.3 Each fabricated member, whether assembled prior dispatch or not so assembled, shall bear an erection mark, which will help to identify the member and its position in respect of the whole structure, to facilitate re-erection at site. This erection mark shall be incorporated in the shop detail and erection drawings.

#### **1.7.31 ERRORS:**

Any error in shop work which prevents proper assembling and fitting up of parts in the field by moderate use of drift pins or moderate amount of reaming will be classified by the Engineer in charge as defective workmanship. All charges incurred by the Engineer either directly or indirectly because of the poor workmanship will be deducted from the amount due to the contractor before payment is made. The amount of such deduction will consist of the sum total of the costs of labour direct or indirect, material, plant, transportation, equipment rental and overhead expenses. In case the Engineer chooses to reject the material because of poor workmanship, the cost of all handling and returning the



material to the contractor, if he so desires, shall entirely be the contractors account. All the replacement materials shall be supplied free and in all such cases, the cost of handling, transport and delivery to site shall be borne by the contractor.

#### **1.7.32 ERECTION:**

1.7.32.1 Erection of structural steel fabricated components shall be done generally in accordance with provisions of IS 800.-2007

1.7.32.2 Before starting of erection work, the contractor shall ensure the fulfillment of the following activities:-

- a) The contractor shall submit, for examination by the Engineer in charge, detailed particulars of his proposed methods of erection of the superstructure steel work, together with complete calculations relating to strength and deflection, if the erection scheme necessitates the attachment of strength steel work to the permanent steel work, the contractor shall submit, for approval of the Engineer in charge, the methods he proposes for making good the permanent steelwork after removing the temporary work. The contractor shall also submit the design and fabrication drawings including detailed calculations of temporary nose, counter weight all temporary support, staging, braces etc. required for safe erection, for approval of the Engineer in charge.
- b) The contractor shall provide all construction and transport equipment, tools, tackle and consumables, materials, labour and supervision required for the erection of the structural steel work.
- c) Handling, assembling, bolting, welding and satisfactory installation of all fabricated structural steel materials in proper location, according to approved erection drawings and/or as directed by the Engineer in charge.
- d) Setting out, aligning, plumbing, leveling, bolting, welding and securely fixing the fabricated steel structures in accordance with the erection scheme or as directed by the Engineer in charge.

#### **1.7.33 ERECTION TOLERANCES:**

Erection tolerances shall be as per table -33 OF IS 800-2007

#### **1.7.34 QUALITY CONTROL & TESTING REQUIREMENTS:**

1.7.34.1 The contractor shall submit the following:

- ❖ Proposed overall schedule for documentation of shop drawings, plan/procedures and records, submission of procedure of fabrication.
- ❖ The contractor shall himself inspect all materials and shop work to satisfy the specified tolerance limits and quality norms before the same are inspected by Engineer in charge.

1.7.34.2 The contractor shall through appropriate planning and continuous measurements in the workshop and the erection at site ensure that the tolerances specified in this specification are strictly adhered to.

1.7.34.3 Fabricating agency shall have in house facilities for all testing of weld.



### 1.7.35 VISUAL EXAMINATION:

The contractor shall conduct visual examination and measurement of the external dimensions of welds for all joints. Before examining the welded joints, areas close to it on both sides of the weld for a width not less than 20 mm shall be cleaned of slag and other impurities. Examination shall be done by a magnifying glass which has a magnification power of ten (10) and measuring instrument which has an accuracy of  $\pm 0.10$  mm or by weld gauges. Welded joints shall be examined from both sides. The contractor shall examine the following during the visual checks.

- i) Correctness and shape of the welded joints
- ii) Incomplete penetration of weld metal
- iii) Influx
- iv) Burns
- v) Un welded craters
- vi) Undercuts
- vii) Cracks in welded spots and heat affected zones
- viii) Porosity in welds and spot welds.
- ix) Compression in welded joints as a result of electrode impact while carrying out contact welding
- x) Displacement of welded element.

The contractor shall, document all data as per sound practices.

1.7.35 In order to exercise proper control of the quality of the welding, contractor shall enforce methods of control as tabulated below:

Purpose	Control subjects	Methods of control
1	2	3
1. control of welding materials and basic metal quality	Quality control of electrodes, welding wire, flux and protective gases.  Welding of	Weld ability test to determine the technological properties of materials.  Mechanical test of weld metal.  Metallographic investigations of welds macro-structure and microstructure.  Checking of weld metal resistance for inter-crystalline corrosion. Study if weld metal solidity by physical control methods.



Bharat Heavy Electricals Limited  
Boiler Auxilaries Plant,  
Ranipet –632 406  
Civil Projects & Services

2. Checking of welders qualifications	specimens for quality determination.	Mechanical tests, metal graphical investigation & checking of welded joints by physical control methods
3. Control of welded joint quality	Control of assembly accuracy and technological welding process.	Checking of assembly quality & centering of welded members.  Checking of welding equipment conditions. Checking correctness of welding procedure. Visual examination of welds.



## SECTION- F

### MATERIAL & PAINTING SPECIFICATIONS

#### 1.0 **MATERIAL**

#### 1.1 **SPECIFICATIONS**

- 1.1.1 Primary members fabricated from plates and sections with minimum yield strength of 345 Mpa or to suit design by continuous welding.
- 1.1.2 Secondary members for Purlins and Girts shall conform to the physical specification of ASTM A570 (Grade 50) or equivalent IS Standards having a minimum yield strength of 345 MPa. The minimum thickness of secondary members shall be 2.5mm.
- 1.1.3 Rod /ANGLE bracing shall conform to the physical specification IS 2062.OF MIN 245MPA YIELD STRENGTH
- 1.1.4 All hot rolled sections shall conform to the physical specifications IS 2062. All other miscellaneous secondary members shall have minimum yield strength of 250 MPa.

#### 1.2 **DESCRIPTION**

##### 1.2.1 **PRIMARY MEMBERS :**

Primary structural framing shall include the transverse rigid frames, columns, corner columns, end wall wind columns and crane gantry girders and Frames at Door openings.

##### 1.2.2 **SECONDARY MEMBERS :**

Secondary structural framing shall include the purlins, girts, eave struts, wind bracing, flange bracing, base angles, clips,flashings and other miscellaneous structural parts. Suitable wind bracings sag rods to be reckoned while designing the structure.

##### 1.2.2 **PURLINS:**

Purlins should be of Pre Galvanised steel of 345 Mpa having a coating thickness of 275 gsm

##### 1.2.4. **ROOF SHEETING :**

Roof panels shall be made out of 26 gauge high tensile steel CLIP-ON profiled sheets having min. yield strength of 550 Mpa conforming to ASTM-A446 with galvalume coating to AZ-150 bare galvalume, as per ASTM A-792-AZ to make TCT of 0.47mm. The profile shall be trapezoidal shaped to satisfy the loading requirements or any other profile if proved to have sufficient strength to take DL, LL ,wind loads.

##### 1.2.5 **Wall Panels**

Wall panel material specifications shall be same as roof panels. They shall be polyester coated of approved standard colour.0.5 TCT The profile shall have a



maximum pitch of 200mm and minimum depth of 26 mm. Alternatively maximum pitch of 333mm with two intermediate stiffening ribs will be acceptable or any other profile if proved to have sufficient strength to take the relevant wind loads.

#### 1.2.6 SHEETING FASTENERS:

Standard fasteners shall be self tapping zinc plated metal screws with EPDM bonded zinc plated washers. All screws shall be color coated to match roof and wall sheeting.

#### 1.2.7 SEALER:

This is to be applied at all side laps and end laps of roof panels and around self flashing windows. Sealer shall be pressure sensitive elastomeric Butyl tapes. The sealer shall be non-asphaltic, non-shrinking and non toxic and shall be superior adhesive metals, plastics and painted at temperatures from 51°C to +104°C.

#### 1.2.8 CLOSURES:

Solid or closed cell closures matching the profiles of the panel shall be installed along the eaves, rake and other locations specified on drawings.

#### 1.2.9 FLASHING AND TRIM:

Flashing and / or trim shall be furnished at the rake, corners, eaves, and framed openings and wherever necessary to provide weather tightness and finished appearance. Color shall be matching with the color of wall. Material shall be 26 gauge thick conforming to the physical specifications of sheeting.

#### 1.2.10 SKY LIGHTS :

Skylight is translucent corrugated sheets matching the profile of Roof. The translucent sheets are made from 2mm thick Polycarbonate sheets and shall provide an economic form of general-purpose day lighting. Skylights shall be provided for 5% of the roof area. Colour of the panel shall be white with smooth surface finish with a light transmitting capacity of 60%  $\pm$  5%.

#### 1.2.11 GUTTERS AND DOWN SPOUTS:

Gutters and downspouts shall be adequately designed to ensure proper roof drainage system. Material shall be same as that of sheeting.

### 1.3 CONNECTIONS :

#### 1.3.1 SITE CONNECTIONS

- a) All primary bolted connections shall be provided with galvanized high strength bolts, washers, nuts conforming to specifications of grade 8.8 OF IS 1367
- b) All secondary bolted connections shall be furnished with bolts, nuts, washers conforming to the specifications of grade 4.6 of IS 1367 or ASTM-A307.



Bharat Heavy Electricals Limited  
Boiler Auxilaries Plant,  
Ranipet –632 406  
Civil Projects & Services

### 1.3.2 SHOP CONNECTIONS

All shop connections shall be welded with appropriate arc welding process and welding shall be in accordance with IS 816,IS-819 ,IS1024,IS-1261 ,IS1323,IS-9595, AWS D 1.1. as appropriate. **The Webs should be welded on to the flanges at both the faces at top and bottom for columns, beams and crane girders.** Weld material should have strength more than the parent metal.

### 1.4 ROOF & WALL BRACINGS

Roof and wall bracings shall have a minimum yield strength of 250 Mpa and shall conform to the specifications IS 2062.

Portal Bracings connecting columns should be min. at two places on both the side walls @ 50m. c/c.

### 1.5 PAINTING FOR STRUCTURAL STEEL WORK:

The cleaning & painting specifications for the Structural Steel work shall be as below

- a) Sandblasting / shot blasting to Sa 2 ½ .
- b) Two shop coats of red oxide zinc phosphate primer (1 x 40 μ)
- c) Two site coats of epoxy finish paint (2 x 40 μ)

The colour of the finish paint shall be approved by the client.

END OF SECTION

GENERAL CONDITIONS OF CONTRACT  
FOR  
LUMP SUM, ITEM RATE AND  
PERCENTAGE CONTRACT

SPECIMEN

civ 02

GCC



**Bharat Heavy Electricals Limited**  
BOILER AUXILIARIES PLANT  
RANIPET - 632406

**GENERAL CONDITIONS OF CONTRACT  
FOR  
LUMP SUM, ITEM RATE AND  
PERCENTAGE CONTRACT**



**Bharat Heavy Electricals Limited**

**BOILER AUXILIARIES PLANT  
RANIPET - 632 406.**

# CONTENTS

Condition No.	Description	Page No.
<b>CHAPTER - I</b>		
1.	DEFINITIONS	1
<b>CHAPTER - II</b>		
<b>SCOPE OF CONTRACT</b>		
2.	HEADING TO THE CONTRACT .....	4
3.	CONTRACT DOCUMENTS .....	4
3A.	SECRECY .....	4
4.	WORKS TO BE CARRIED OUT .....	4
5.	PROVISIONAL ITEMS .....	5
6.	DEVIATIONS .....	5
7.	TIME .....	6
8.	STORES & MATERIALS .....	7
9.	DELAY & EXTENSION OF TIME .....	9
10.	PATENT RIGHTS .....	10
11.	OCTROI & OTHER DUTIES .....	10
12.	ROYALTIES .....	10
13.	PLANT & EQUIPMENT .....	10
14.	ASSIGNMENT OR TRANSFER OF CONTRACT .....	11
	a) SUB - CONTRACT .....	11
15.	COMPLIANCE TO REGULATIONS AND BYE-LAWS .....	11
16.	DELETED .....	11
17.	DELETED .....	11

## CHAPTER - III

### SCOPE OF CONTRACT

18.	SECURITY DEPOSIT .....	12
19.	ORDERS UNDER THE CONTRACT .....	13
20.	ADMISSION TO SITE .....	13
21.	CONTRACTOR'S SUPERVISION .....	14
22.	LABOUR LAWS .....	15
23.	SAFETY RULES .....	15
24.	WATER .....	15
25.	TEMPORARY WORKSHOPS, STORES ETC. ....	15
26.	TOOLS & PLANT ON SITE .....	16
27.	STATEMENT OF HIRE CHARGES .....	16
28.	PRECAUTIONS AGAINST RISKS .....	16
29.	NOTICE & FEES .....	16
30.	SETTING OUT OF THE WORKS & PROTECTING & MAINTAINING SIGNALS AND WORKS .....	16
31.	SITE DRAINAGE .....	17
32.	EXCAVATIONS, RELICS ETC., .....	17
33.	FOUNDATIONS .....	17
34.	COVERING IN WORK .....	17
35.	APPROVAL OF WORKS BY STAGES .....	18
36.	EXECUTION OF WORKS .....	18
37.	DAY WORK .....	18
38.	INSPECTION OF THE WORK .....	18
39.	RESPONSIBILITY FOR BUILDING .....	19
40.	INSURANCE OF WORKS .....	19

41.	DAMAGE AND LOSS TO PRIVATE PROPERTY & INJURY TO WORKMEN .....	20
42.	COMPLETION .....	20
43.	COMPENSATION FOR DELAY .....	21
44.	LAWS GOVERNING THE CONTRACT .....	21
45.	CANCELLATION OF CONTRACT FOR CORRUPT ACT .....	22
46.	CANCELLATION OF CONTRACT FOR INSOLVENCY .....	22
	ASSIGNMENT OF SUB-LETTING OF CONTRACT	
47.	CANCELLATION OF CONTRACT FOR DEFAULT .....	23
48.	TERMINATION OF CONTRACT FOR DEATH .....	24
49.	SPECIAL POWERS OF DETERMINATION .....	24
50.	DELETED .....	24

## CHAPTER - IV

### VALUATION AND PAYMENT

51.	RECORDS & MEASUREMENTS .....	25
52.	VALUATION OF DEVIATIONS .....	26
53.	REIMBURSEMENT / REFUND ON VARIATION IN PRICE .....	27
54.	ADVANCES ON ACCOUNT .....	28
55.	FINAL BILL .....	29
56.	PAYMENT OF BILLS .....	29
57.	RECOVERY FROM CONTRACTORS .....	30
58.	POST-TECHNICAL AUDIT OF WORK AND BILLS .....	30
59.	REFUND OF SECURITY DEPOSIT .....	30
60.	ARBITRATION .....	30
61.	JURISDICTION OF COURT .....	31
62.	PAYMENT OF TAXES, DUTIES & LEVIES .....	31

## ANNEXURE

LABOUR LAWS	ANNEXURE - I .....	32
SAFETY RULES	ANNEXURE - II .....	50

## CHAPTER - I

### DEFINITIONS IN THE CONTRACT AS HEREINAFTER DEFINED

The following terms shall have the meanings hereby assigned to them, except here the context otherwise requires :-

- a. **'CONTRACT'** means and includes the conditions of contract, the documents forming the tender and acceptance, thereof, specifications, drawings, bill of quantities, schedule of rates and prices if any, general and special conditions of contract, schedules A,B,C,D and or general summary attached to the form of tender and contract agreements. All these terms and conditions and documents as applicable taken together shall be deemed to form one contract and thereby complementary to one another.
- b. **'TENDER DOCUMENTS'** means and includes the form of tender, the applicable schedules A, B, C, D and / or general summary, general and special conditions of contract and specifications and drawings as given to the contractors on payment.
- c. **'THE CONTRACTOR'** means the person or persons, firm or company whether incorporated or not, whose tender is being accepted and includes the contractor's legal / personal representatives, successors and permitted assignees.
- d. **'THE WORK'** means the work described in the tender documents and / or individual work orders, drawings and specifications as may be issued from time to time to the contractor by the Engineer - In - Charge within the powers conferred upon them including modified or additional works and obligations to be carried out either at the site or at any factory, workshop or any other place as required for the performance of the contract.
- e. **'THE SITE'** means the lands and other places on, under, in or through which the work has to be executed under the contract and any other lands and places provided by the company for the purpose of carrying out the contract.
- f. **'THE COMPANY'** referred to as BHEL in this contract shall mean M/s. Bharat Heavy Electricals Limited including its Board of Directors, Director, Executive Director, Group General Manager, General manager, Dy. General Manager and / or the Officers of the company including Sr. Manager, Manager, Dy. Manager, Sr. Engineer and Engineer authorised on behalf of Bharat Heavy Electricals Limited, Boiler Auxiliaries Plant, Ranipet.
- g. **'THE ACCEPTING OFFICER'** means the official who signs the contract agreement on behalf of Bharat Heavy Electricals Limited and includes his successors.
- h. **'ENGINEER-IN-CHARGE'** means the Officer / Engineer of BHEL who is in charge of works under the contract and includes such other Officer / Engineer as may be notified by BHEL from time to time.
- i. **'APPROVED AND DIRECTED'** means approval and / or directions of the Officers / Engineers of BHEL issued from time to time with regard to the contract.

- j. In the case of Lump-sum Contracts '**CONTRACTOR'S PERCENTAGE**' means the percentage offered by the Contractor as addition to our deduction from the cost of building, or other works listed in Schedule "A" to provide a Lump-sum quotation for performance of the contract inclusive of all extra costs, profit, establishment charges, carriage, insurance etc., complete.
- In the case of percentage Rate "Contracts Contractor's Percentage" shall, if the context so permits mean the uniform percentage tendered by the Contractor and accepted by the Accepting Officer; and the expression '**CONTRACT RATE**' shall likewise mean the rates in the BHEL Schedule of Rate applicable as on date as adjusted by the said Contractor's percentage, if any.
- k. '**THE CONTRACT SUM**' means the sum accepted or the sum calculated in accordance with the prices accepted in the tender and / or the contract rates as payable to the contractor for the execution and full completion of the work.
- l. The '**FINAL SUM**' means the actual amount payable under the Contract by BHEL, to the Contractor for the entire Execution and full completion of the work.
- m. The '**DATE OF COMPLETION**' is the date or dates for completion of the whole or any part of the work as the case may be set out in or ascertained in accordance with the individual work orders of the tender documents, or any subsequent agreed amendments thereto.
- n. A '**WEEK**' means seven days without regard to the number of hours worked or not in any day in that week.
- o. A '**DAY**' means a day of 24 (Twenty Four) hours irrespective of the number of hours worked or not in that day.
- p. A '**WORKING DAY**' means any day other than the holidays declared by BHEL, Ranipet.
- q. '**DEVIATION ORDER**' means an order given by the Engineer-in-Charge to effect an alternation addition or deduction which does not radically affect the scope or nature of the contract.
- r. '**EMERGENCY WORKS**' means any urgent measures which in the opinion of the Engineer-In-Charge, become necessary during the progress of the work to obviate any risk of accident or failure which become necessary for security.
- s. '**PROVISIONAL SUM**' or "Provisional Lump-sum" means a Lump-sum included by the BHEL in the tender documents and represents the estimated value of work for which details are not available at the time of inviting the tender.
- t. '**PROVISIONAL ITEMS**' means items for which approximate quantities have been included in the tender documents.
- u. '**DAY WORK**' means an item of work requiring the employment of labour with or without materials as the case may be which in the opinion of the Engineer-in-charge, is not capable of being evaluated by the accepted methods of measurement or assessment and is paid for on the basis of the actual labour and materials utilised on the particular item of work referred to.

- v. Heading of these terms and conditions shall not affect the interpretation or construction thereof.
- w. The '**DATE OF CONTRACT**' shall mean the date / dates on which the parties to the contract have signed the contract agreement.
- x. **MAINTENANCE PERIOD / GUARANTEE PERIOD** shall mean the period during which the contractor shall remain liable for satisfactory performance of the work under the contract, repair or replacement of any part of the work performed under the contract.
- y. '**COST**' shall mean and include any liability, expenditure, overhead costs whether on the site or off the site incurred by BHEL.

The contractor shall be deemed to have carefully examined all the documents to his satisfaction. If he shall have no doubt as to the manner of the contract document, he shall obtain the details/clarification from BHEL before signing the contract.

#### **MANNER OF EXECUTION OF CONTRACT**

The contract shall be deemed to have come into force from the date of Letter of Intent unless otherwise provide in the Letter of Intent. Unless and until the contract agreement is executed, the Letter of Intent read in conjunction with the tender documents will constitute a binding contract.

**CONTRACTOR / TENDER**

**ACCEPTING OFFICER**

## CHAPTER - II

### SCOPE OF CONTRACT

#### 2. Heading to the Contract

The heading to these conditions shall not affect the interpretation thereof.

#### 3. Contract Documents

The Accepting Officer shall furnish to the Contractor on demand "FREE OF COST" three copies of signed Drawings and one copy of the signed agreement comprising of preamble to agreement, General and Special Specification, Schedule A,B,C & D etc., (but excluding General Conditions of Contract and Drawings) and three copies of all further drawing issued the progress of work.

However, for any additional copies of the agreement of drawings required by the Contractor, the same will be supplied on payment of the Specified cost.

The Contractor shall keep one copy of all the Drawings and of the Specifications on the site and the Engineer-in-Charge or his representative shall be at all reasonable times have access to them.

None of these documents shall be used by the contractor for any purpose other than that of this contract.

#### 3a. Secrecy

The Contractor shall take necessary steps to ensure that all persons employed on any work in connection with this contract have noted that the Indian Officials Secrets Act 1923 (XIX of 1923) applies to them and shall continue so to apply even after the execution of such work under the contract.

All classified documents furnished to the contractor shall be returned to the Engineer-in-charge on the completion of works or the earlier determination of the Contract.

#### 4. Works to be Carried Out

The Contract shall, except as provided under Schedules "B" and "C" included all labour materials, tools, plant, equipment, and transport which may be required in preparation for and in the entire execution and full completion of the work. Schedule "A" shall be deemed to have been prepared in accordance with good practice and recognised principles and unless otherwise stated, the descriptions given therein shall be held to include waste on materials carriage and cartage, lead, hoisting, setting, fitting in position and all other labour necessary in and for the entire execution and full completion aforesaid. Any error in description or quantity in Schedule "A" or any omission therefrom shall not vitiate the Contract or release the Contractor from the execution of the whole or any part of the work comprised therein according to the Drawings and Specifications, or from any of his obligations under the Contract.

The insertion of the name of any firm of suppliers in the Tender Documents is for the purpose of obtaining a particular class or quality of materials or workmanship but the articles or materials specified may be obtained from any other firm subject to prior written approval of the Engineer-in-Charge.

In the case of a discrepancy between Schedule "A" the specification and / or the Drawings, the Accepting Officer shall be the sole deciding authority as to which shall prevail and his decision shall be final and conclusive. If neither Drawings nor specifications contain any mention of minor details of construction, which is in the opinion of the Accepting Officer, whose decision shall be final and conclusive, are reasonable and obviously and fairly intended for the satisfactory completion of the work, such details shall be provided by the Contractor without any extra cost as if they were specially mentioned and shall be deemed to be included in the contract.

The Contractor will be deemed to have satisfied himself as to the nature of the site, local facilities of access and all matters affecting the execution and completion of the work. No extra charges consequent on any mis-understanding in these respects or otherwise will be allowed.

#### **5. Provisional Items**

The full amount of provisional Lump-sums and the value annexed to each provisional item inserted in the Tender Documents shall be deducted from the contract sum and the value of work ordered and executed there under shall be ascertained by measurement or valuation as for deviations.

No work under these items is to be begun without instructions in writing from the Engineer-in-charge.

The extent of quantities or items described as "Provisional" shall not be held to guarantee or limit the amount and description of the work to be executed by the Contractor either in respect of the items concerned or the work as a whole.

No addition or deduction shall be made by the Contractor to the amount of the provisional Lump-sum as included in the tender documents.

#### **6. Deviations**

The contractor shall not make any alteration in addition to or omission from the work as described in the tender documents except in pursuance of the written instructions of the Engineer-in-charge. No such deviation from the work described in the tender documents shall be valid unless the same has been specifically confirmed and accepted by the Accepting Officer in writing and incorporated in the contract.

The Accepting Officer may deviate either by way of addition or deduction, from the work so described, provided that the contract sum be not thereby varied on the whole by more than percentage set out in the tender documents. The value of all additions and deductions will be added to or, deducted from the contract sum, when ever the Accepting Officer intends to exercise such a right, his intentions shall specify the deviations which are to be made, the Lump-sum assessment or the proposed basis of payment, the extra time allowed, if any, and the date for completion of the entire contract.

Any objection by the Contractor to any matter concerning the order shall be notified by him in writing to the Engineer-in-charge within seven days from the date of such order, but under no circumstances shall the work be stopped (unless so ordered by the Engineer-in-charge) owing to differences or controversy that may arise from such an objection. In the absence such notification of objection by the contractor, he will be deemed to have accepted the order and the conditions stated therein. In the event of the contractor failing to agree with the Engineer-in-charge regarding the terms of the proposed deviation, the objection shall be referred to the Head of Civil Engineering Department whose decision shall be final, conclusive and binding on the contractor.

## **7. Time**

Time is the essence of the contract and is specified in the tender documents or in each individual Work Order.

As soon as possible after the contract is let or any substantial Work Order is placed and before work order is to begin, the Engineer-in-charge and the Contractor shall agree to a Time and progress Chart. The Chart shall be prepared in direct relation to the time stated in the tender documents or the Work Order for the completion of the individual items there of and the contract or order as a whole. It shall indicate the fore cast of the dates for the commencement of the various trade processes or sequence of the work, and shall be amended as may be required by agreement between the Engineer-in-charge and the Contractor within the limitation of the time imposed in the tender, document or order.

In the absence of any specific Time and Progress chart to be agreed to between the Contractor and Engineer-in-charge the contractor shall ensure and maintain uninterrupted progress of the work such that the entire work shall be completed within the time imposed in the Tender documents or Order and that the proportion of the work completed upto any time in relation to the entire work to be under the Contract or Order shall not be less than the proportion that the time elapsed bears to the total time of completion provided in the Tender documents or Order.

The Contractor shall suspend the execution of the work, or any part or parts thereof whenever call upon in writing by the Engineer-in-charge to do so, and shall not resume work there on until so directed in writing by the Engineer-in-charge. The Contractor will be allowed an extension of time for completion not less than the period of suspension. However, no other claim in this respect for compensation or otherwise however will be amitted. Provided the cause for suspension is not attributable to any default of the contractor's part to proceed with or fulfil the contractual obligations. This may also be extended to allow for alteration of work made by the deviation order.

## **8. Stores and Materials**

### **8.1 Materials to be supplied by the Contractor**

The Contractor shall at his own cost and expense provide all materials required for the work other than those listed in Schedule-B which are to be supplied by Bharat Heavy Electricals Ltd.

All materials to be provided by the Contractor shall be brand new and in conformity with the specifications laid down in the contract and the Contractor shall if requested by the Engineer-in-charge furnish proof, to the satisfaction of the Engineer-in-charge, that the materials so comply.

The Contractor shall at his own cost and expense and without delay, supply to the Engineer-in-charge samples of materials proposed to be used in the works. The Engineer-in-charge shall within seven days of supply of samples or within such further period as he may require and intimate to the Contractor in writing, inform the Contractor whether samples are approved by him or not. If samples are not approved, the Contractor shall forthwith arrange to supply to the Engineer-in-charge for his approval fresh samples complying with the specification laid down in the contract.

The Engineer-in-charge shall have full powers to require removal of any or all of the materials brought to site by the Contractor which are not brand new and not in accordance with the contract specifications or do not conform in character or quality to samples approved by him. In case of default on the part of the Contractor in removing rejected materials, the Engineer-in-charge shall be at liberty to have them removed by other means at the Contractor's expense and risk. The Engineer-in-charge shall have full power to require other proper materials to be substituted for rejected materials and in the event of the contractor refusing to comply, he may cause the same to be procured by other means. All costs charges and expenses which may attend such substitution shall be borne by the contractor. All charges on account of Octroi, terminal or sales tax and other duties on material obtained for the works from any source (excluding materials supplied by BHEL) shall be borne by the Contractor.

The Engineer-in-charge shall be entitled to have tests carried out as specified in the Contract for any materials supplied by the Contractor other than those for which, as stated above, satisfactory proof has already been furnished, at the cost of the Contractor and the Contractor shall provide at his expense all facilities which the Engineer-in-charge may require for the purpose.

## **8.2 Materials to be supplied by BHEL**

Materials which BHEL are prepared to supply are shown in Schedule-B which also stipulates place of issue and rate(s) to be charged in respect thereof soon after acceptance of the tender the Contractor shall agree in writing with the Engineer-in-charge on a phased programme of his requirements with regard to deliver of materials.

In the event of delay in supply of any Stores and materials mention in Schedule-B the contractor shall be entitled to reasonable extension of time as provided for under condition-9 but no claim for compensation or damage on any ground whatsoever shall be entertained by BHEL.

For the materials listed in Schedule-B the contractor shall give a reasonable notice in writing of his requirement to the Engineer-in-charge in accordance with the phased programme.

All materials issued to the Contractor by BHEL for incorporation or fixing in the works shall on completion or on fore-closure of the works and before submission of bills, be returned by the Contractor at his expense, at the place of issue, after making due allowance for actual consumption reasonable wear and tear and for waste. In the Contractor is required to deliver such materials at a place other than the place less the transportation charges which would have been incurred by the Contractor had such materials been delivered at the place of issue, shall be borne by BHEL.

The Contractor shall bear the cost of loading, transporting to site, unloading storing under covered area as necessary, assembling and joining the several parts together as necessary and incorporating or fixing materials in the work including all preparatory work of whatever description as may be required, and of closing preparing, loading and returning empty cases or containers to the place of issue.

If, in the opinion of the Engineer-in-charge (which shall be final and conclusive) any stores supplied by BHEL have either during currency of the work or after completion of the work whilst under custody, of the contractor, become damaged to such an extent that they cannot be usefully utilised, either in the same work or in other works, the Engineer-in-charge shall not accept the stores and in the rates specified in the contract. The contractor shall not be entitled to any claim whatsoever on this account.

The Engineer-in-charge shall have access to the stores where materials issued by BHEL as per schedule -B of the contract is stored to ensure the balance stock of material on hand after taking into consideration the materials used on the work is as per the issue and usage. If there be any discrepancy, the cost towards the same will be recovered at the double recovery rate indicated for the material concerned. This is without prejudice to and in addition to the overall reconciliation of materials to be made at the completion of work.

If on completion of works, the Contractor fails to return surplus materials out of those supplies by BHEL then, in addition to any other liability which the Contractor would incur, the Engineer-in-charge may, be written notice to the Contractor, require him to pay within a fortnight of receipt of the notice for such un-returned surplus materials given in sub para-4.

The Contractor shall have to build a weather-proof shed <sup>for</sup> or the storage of Cement (required for 15 days consumption of the work).

### 8.3 General

Materials required for the works, whether brought by the Contractor or supplied by BHEL shall be stored by the Contractor only at places approved by the Engineer-in-charge. Storage and safe custody of materials shall be at the risk and the responsibility of the Contractor.

Officials concerned with contract shall be entitled at any time to inspect and examine any materials intended to be used in or in the works either on the site or at factory or workshop or other places where such materials are assembled, fabricated or manufactured or at any place(s) where these are lying or from which these are being obtained and the Contractor shall give such facilities as may be required for such inspection and examination.

All materials brought to the site shall not be removed off the site without the prior written approval of the Engineer-in-charge. But whenever the works are finally completed and advance if any, in respect of any such materials is fully recovered the Contractor shall at his own expense forthwith remove from the site all surplus materials originally supplied by him and upon such removal the same shall revert in and become the property of the Contractor.

Should the Engineer-in-charge consider at any time during the construction or re-construction prior to the expiry of the MAINTENANCE PERIOD that the stores or materials provided by the Contractor are unsound or of a quality inferior to that contracted for or otherwise not in accordance with Contract (in respect where of the decision of the Engineer-in-charge shall be final and conclusive) the Contractor shall on demand in writing from the Engineer-in-charge specifying the Stores or materials complained of notwithstanding that the same may have been inadvertently passed, certified and paid for, forthwith remove the Stores or materials so specified and provide other proper and suitable stores or materials at his own expense, to the entire satisfaction of the Engineer-in-charge and in the event of his failing to do so within a period to be specified by the Engineer-in-charge in his demand aforesaid the Engineer-in-charge may replace with others the Stores or materials complained of at the risk and expense in all respects of the Contractor. The liability of the Contractor under this condition shall not extend beyond the maintenance period aforesaid except as regards Stores or materials which the Engineer-in-charge shall have previously given notice of to be Contractor to replace.

#### **9. Delay and Extension of Time**

If, in the opinion of Engineer-in-charge the work is delayed :

- i) by reason of abnormally bad weather, OR
- ii) by reason of serious loss or damage by fire OR
- iii) by reason of Civil commotion local combination of workmen, strike or lockout, affecting any of the trades employed on the work, OR
- iv) by delay on the part of the agency or tradesman engaged by BHEL in executing work not forming part of this Contract OR
- v) by reason of any other cause which in the absolute discretion of the Engineer-in-charge is (when he is the Accepting Officer of the Contract), beyond the Contractor's reasonable control, then in such cases the Accepting Officer, on the recommendation of the Engineer-in-charge or higher authority may make fair and reasonable extension in the completion dates of the individual items of work of the Contract as a whole. Such extension which will be communicated to the Contractor by the Engineer-in-charge in writing shall be final and binding on the Contractor. No other claim in this respect for compensation or otherwise howsoever is admissible. Upon the happening of any such event causing delay, the Contractor shall immediately give notice thereof in writing to the Engineer-in-charge but shall nevertheless use constantly his best endeavour to prevent or make good the delay and shall do all that may reasonably be required to the satisfaction of the Engineer-in-charge to proceed with the work.

#### **10. Patent Rights**

The Contractor shall fully indemnify BHEL or the agent, servant, employee of BHEL against any action, claim or proceeding relating to infringement or the use of any patent or design or any alleged patent or design rights, and shall pay any royalties which may be payable in respect of any article / or part thereof included in the Contractor. In the event of any claim, being made or action brought against BHEL or any agent, or servant or employee of BHEL in respect of the matters aforesaid, the Contractor shall immediately be notified thereof for taking necessary action provided that payment of indemnity shall not apply when such infringement has taken place in complying with the specific directions issued by the BHEL but the Contractors shall pay any royalties payable in respect of any such use.

#### **11. Octroi and Other Duties**

All changes on account of Octroi, Terminal or Sales Tax and / or other duties on materials obtained for the Work (excluding materials provided by BHEL on payment) shall be borne by the Contractor.

#### **12. Royalties**

Royalties fixed from time to time as per prevalent local rules will be recovered for materials, which the Contractor may be allowed to remove from quarries situated on land which is in charge of the BHEL authorities.

#### **13. Plant and Equipment**

The Contractor, shall at his own expense, supply all tools, plant and equipment (here-in-after referred to as T & P) required for the execution of the contract other than those listed in Schedule - C which subject to their availability may be hired by BHEL to the Contractor or issued free for use in the execution of the work, as specified in Tender documents.

#### **14. Assignments or Transfer of Contract**

The Contractor shall not without the prior written approval of the Accepting Officer assign or transfer the Contract or any part thereof, or any share, or interest there in to any other person. No sum of money which may become payable under the Contract shall be payable to any person other than the Contractor unless the prior written approval of the Accepting Officer to the assignment or transfer of such money is given.

#### **14 (a) Sub - Contract**

The Contractor shall not sub-let any portion of the Contract without the prior written approval of the Accepting Officer.

**15. Compliance to the Regulations and Bye - Laws**

The Contractor shall conform to the provision of any statute relating to the work and regulations and bye-laws of any local authority and of any water and lighting Companies or Undertakings with whose system the work is proposed to be connected. He shall, before making any variation from the drawings or the specifications that may be necessitated for such connections give the Engineer-in-charge notice, specifying the variation proposed to be made and the reasons there for and shall not carryout any such variation until he has received instructions from the Engineer-in-charge in respect thereof. The Contractor shall be bound to give all notice required by Statute Regulations of Bye-laws as aforesaid and to pay all fees and taxes payable to any authority in respect thereof.

**16. BLANK**

**17. BLANK**

## CHAPTER – III

### PERFORMANCE OF THE CONTRACT

#### 18. Security Deposit

18.1.1 Security Deposit should be collected from the successful tenderer. The rate of Security Deposit will be as below:

Upto Rs. 10 lakhs	10%
Above Rs. 10 lakhs up to Rs.50 lakhs	1 lakh+7.5% of the amount Exceeding Rs. 10 lakhs.
Above Rs. 50 lakhs	Rs.4 lakhs + 5% of the amount Exceeding Rs. 50 lakhs.

The security Deposit should be collected before start of the work by the contractor.

18.1.2 Security Deposit may be furnished in any one of the following:

- i) Pay Order, Demand Draft in favour of BHEL.
- ii) Local cheques of scheduled banks, subject to realization.
- iii) Securities available from Post Offices such as National Savings Certificates, Kisan Vikas Patras etc.  
(Certificates should be held in the name of Contractor furnishing the security and duly pledged in favour of BHEL and discharged on the back).
- iv) Bank Guarantee from Scheduled Banks / Public Financial Institutions as defined in the Companies Act subject to a maximum of 50% of the total security deposit value. The balance 50% has to be remitted either by cash or in the other form of security. The Bank Guarantee format should have the approval of BHEL.
- v) Fixed Deposit Receipt issued by Scheduled Banks / Public Financial Institutions as defined in the Companies Act. The FDR should be in the name of the contractor, A/C BHEL, duly discharged on the back.
- vi) Security deposit can also be recovered at the rate of 10% from the running bills. However in such cases at least 50% of the Security Deposit should be collected before start of the work and the balance 50% may be recovered from the running bills.
- vii) EMD of the successful tenderer shall be converted and adjusted against the security deposit.
- viii) The security deposit shall not carry any interest.

**NOTE:** Acceptance of Security Deposit against Sl. No. (iv) and (vi) above will be subject to hypothecation or endorsement on the documents in favour of BHEL. However, BHEL will not be liable or responsible in any manner for the collection of interest or renewal of the documents or in any other matter connected therewith.

**CONTRACTOR**

- 18.1.3** Security deposit shall not be refunded to the contractor except in accordance with the terms of the contract.
- 18.1.4** All compensation or other sums of money payable by the contractor to BHEL, under the terms of this contract or under any other contract with BHEL, may be deducted from the security deposit or realized by the sale of the securities or from the interest arising there from or from any sums which may be due or may become due to the contractor payable by BHEL on any account whatsoever against this contract or any other contract with BHEL, and in the event of his security deposit being reduced by reason of such deduction or sale as aforesaid, the contractor shall within seven days thereafter make good in cash or in securities endorsed as aforesaid, any sum or sums by which the security deposit has been so reduced.
- 18.1.5** 50% of the security deposit may be refunded on completion of the work after payment of the final bill and the balance 50% of the security deposit is refundable only after the expiry of the maintenance period of six (6) months from date of completion of work as stipulated in the contract concerned.

## **19. Orders under the Contract**

All orders, notices, etc., to be given under the contract shall be in writing, typescript or printed and if sent by registered post to the address given in the tender of the Contractor, shall be deemed to have been served on the date when in the ordinary course they would have been delivered to him.

The Contractor shall carry out without delay all orders given to him.

## **20. Admission to Site**

The contractor shall not enter on (other than for inspection purposes) or take possession of the site unless permitted to do so by the Engineer-in-charge. The portions of the site to be occupied by the Contractor will be clearly defined and marked on the site plan, and the contractor will on account be allowed to extend his operations beyond these areas. The Contractor shall provide if necessary or required at the site, temporary access there to and shall alter, modify and maintain the same as required from time to time. He shall out and clear away the access route when no longer required restoring the area to its original condition.

The Engineer-in-charge shall have power to execute other works (whether or not connected with the work, in the contract agreement) on the site contemporaneously with the execution of the original work and contractor shall give reasonable facilities for this purpose.

BHEL reserves the right of taking over, at any time, any portion of the site which they may require and the contractor shall at his own expense clear such portion forthwith. No photographs of the site or of the work or any part here of shall be taken published or otherwise circulated without the prior approval of the Engineer-in-charge.

No such approval shall ~~however~~ <sup>however</sup> exempt the Contractor from complying with any statutory provision in regard to the taking and publication of such photographs.

BHEL Officials connected with the Contract shall have the right of entry to the site at all times.

Engineer-in-charge shall have the power to exclude from the site any person whose admission there to may, in his opinion be undesirable for any reason whatsoever

The Contract shall be governed by the security regulations of BHEL including the entry exit timings, use of roads as may be in force from time to time. The Contractor should follow these regulations strictly and no claims for any additional payment whatsoever will be entertained under by circumstances.

## 21. Contractors Supervision

The Contractors shall either himself supervise the execution of the Contractor or shall appoint a competent Agent approved by the Engineer-in-charge to act in his stead. The Contractor shall employ an Engineer/Agent having atleast a Degree of Bachelor of Civil Engineer from a recognised University/on any work with a Contract value exceeding rupees two lakhs, and having atleast a Diploma in civil Engineering from a recognised college, on work with a contract value exceeding Rs. 50,000/- but not exceeding rupees two lakhs.

The Employment of an Engineer/Agent as aforesaid shall not be necessary if the Contractor himself is in possession of a recognised technical qualification and is, in opinion of the Engineer-in-charge, capable of the receiving instructions of the Engineer-in-charge and of the executing the work to the satisfaction of the Engineer-in-charge. If the Contractor fails to appoint a suitable Engineer/Agent as aforesaid, the Engineer-in-charge shall have full powers to suspend the execution of work and stop payment of any advances that may have become due until such date as a suitable Engineer/Agent is appointed and the Contractor shall be held responsible for the delay caused to the work and no extension of time on this account shall be given to him as stipulated in condition (9) above.

Orders given to the Contractor's Agent Engineer shall be considered to have the same force as if they had been given contractor himself.

The Contractor or his Agent shall be in attendance at the site during all working hours and shall superintend the executing of work with such additional assistance in each trade as the Engineer-in-charge may consider necessary.

The Contractor or his accredited agent shall attend when required and without making any claim for doing so, either the Office of the Engineer-in-charge or the work site to receive instructions.

The Engineer-in-charge shall have full powers, and without assigning any reason to require the Contractor immediately to cease to employ in connection with the

Contract any Agent, servant or employee whose continued employment is, in his opinion undesirable

The contractor shall not be allowed any compensation on this account.

## **22. Labour**

The contractor shall employ labour in sufficient number either directly or through sub-contractors to maintain the required rate of progress and of quality ensure workmanship of the degree specified in the contract and to the satisfaction of the Engineer-in-charge. The contractor shall comply with all labour laws in force from time to time.

## **23. Safety Rules**

The Contractor shall comply with all safety rules of BHEL.

## **24. Water**

The Contractor shall allow in his Tender and provide at his cost all water required for the work or his employees on the work, together with all pipes and fittings or other means that may be necessary or required to ensure a proper and ample supply of water for all purposes connected with the work.

In the event of a provision existing in the Tender documents for supply of water on payment by Bharat Heavy Electricals Limited, water will be supplied from the BHEL supply system or other sources at any points fixed by the Engineer-in-charge on the site of work. The contractor shall make necessary arrangement for lifting pumping carrying or conveying the water as required at his own cost. The levy of water charges to be borne by the contractor in such case shall be specifically mentioned in the Tender documents.

## **25. Temporary workshops, store Etc,**

The Contractor shall, during the progress of the work provide, erect and maintain at his own expense all necessary temporary workshops, offices etc., required for the proper and efficient execution of the work. The planning, siting, and erection of these buildings shall have the approval of the Engineer-in-charge and the Contractor shall all at times keep them tidy and in a clean and sanitary condition to the entire satisfaction of the Engineer-in-charge.

On completion of the work all such temporary building shall be cleared away and the site restored and left in a clean and tidy condition to the entire satisfaction of the Engineer-in-charge.

## **26. Tool and Plant on site**

All tools, plant and equipment brought to the site shall not be removed from the site without the prior written approval of the Engineer-in-charge when the work is finally completed or the contract is determined for reasons other than the default of the contractor he shall forthwith remove from the site all tool, plant, equipment etc., (other than those as may have been provided by BHEL)

## **27. Statments of Hire Charges**

A monthly detailed statement of the hire charge incurred in respect of BHEL tools, plant, equipments etc., shall be given to the Contractor by the Engineer-in-charge.

## **28. Precaution Against risks**

The Contractor shall be responsible for providing at his own expense, for all precaution to prevent loss or damage and for the necessary steps to be taken for the said purpose until the works have been handed over complete, in all respects to the Engineer-in-charge.

The Contractor shall provide all watchman necessary for the protection of the site, the work, the materials, tools, plant, equipment and anything else lying on the site during the progress of the work. He shall solely be responsible for and shall take all reasonable and proper steps for protecting, securing, lighting and watching all places on or about the work and the site which may be dangerous to any person whomsoever.

## **29. Notices and fees**

The Contractor shall give all notices required by any Statutory provision or by the regulations and/or bye-laws of any local / or of any same are or will be connected. The contractor shall pay and indemnify BHEL against any statutory fees and charges payable under such Acts. Regulation and / or bye-laws in respect of the work and shall make and supply all drawings and plans required in connection with any such notice.

## **30. Setting out of the works and Protective and Maintaining signals and works**

The Engineer-in-charge shall supply dimensioned drawings, levels and other information necessary to enable the contractor to set out the work. the contractor shall at his own expense set accurately according to the drawings and figured dimension thereon, all the work comprised in the contract and any extras or additions there to and shall be solely responsible for their being so set out and executed.

All bench marks, pegs, signals on the surface alignment stones, milestones and all similar marks whether put in by BHEL Authorities for the purpose of checking the Contractor's work or in the nature of permanent survey marks will during the tenure of the contract, be under the care of the Contractor who shall at his own expense take all proper and reasonable precautions and care to preserve and maintain them in their true position. In the event of these marks being disturbed or obliterated by accident or due to any other cause whatsoever, the same may, if deemed necessary be replaced by the Engineer-in-charge at the Contractor's expense and the cost thereof deducted from any money then or thereafter becoming due to the Contractor.

Where requested by the Contractor, the level marks, centre line and chainage pegs corresponding to those shown on the Drawing will be pointed out to the Contractor on the ground but all bench marks or chainage pegs additional to those shown on the Drawing will be set out by BHEL authorities.

### **31. Site Drainage**

All water that may accumulate on the site during the progress of the work, or in trenches and excavations shall be removed to the entire satisfaction of the Engineer-in-charge and at Contractor's expense.

### **32. Excavation, Relics, etc.**

Materials of any kind obtained from excavation on the site shall remain the property of BHEL and shall be disposed off as Engineer-in-charge directs.

All gold, silver, oil and other minerals of any description and all precious stones coins treasures, relics, antiquities and other similar items which may be found in or upon the site shall be the property of Bharat Heavy Electricals Limited and the contractors shall duly preserve the same to the satisfaction of the BHEL and shall from time to time deliver the same to such person or persons as the BHEL may appoint to receive the same.

### **33. Foundations**

The Contractor shall not lay any foundations until the excavations for the same have been examined and approved in writing by the Engineer-in-charge.

### **34. Covering - in work**

The Contractor shall give reasonable notice in writing to the Engineer-in-charge whenever any work is to be permanently covered up or concealed, whether by earth or other means so that it can finally be inspected or measured, if necessary. In default of so doing, the Contractor shall if required by the Engineer-in-charge uncover such work at his own expense.

### **35. Approval of Works by Stages**

All work embracing more than one process shall be subject to examination and approval at each stage thereof and the Contractor shall give due notice in writing to the Engineer-in-charge when each stage is ready. In default of such notice being received, the Engineer-in-charge shall be entitled to approve the quality and extent thereof at any time he may choose and in the event of any dispute, the decision of the Engineer-in-charge thereon shall be final conclusive.

### **36. Execution of the work**

The work shall be executed in a workman like manner and to the satisfaction in all respects of the Engineer-in-charge.

The Engineer-in-charge will communicate or confirm his instructions to the Contractor in respect of the execution of the works in a "Work Site Order Book" maintained at his office and the Contractor shall visit this office daily and shall confirm receipt of such instruction by signing the relevant entries in this book. Such entries will rank as order to notices in writing the intent and meaning of these conditions.

### **37. Day Work**

No day - work shall be performed without the prior written instructions of the Accepting Officer.

The Contractor shall give to the Engineer-in-charge reasonable notice of the start of any work ordered to be executed by day-work and shall deliver to the Engineer-in-charge within two days of the end of each pay week a return in duplicate giving full detailed accounts of labour and materials for the payweek. One copy of each of these returns, if found correct will be certified by the Engineer-in-charge and returned to the Contractor and must be produced at the time of adjustment of accounts.

An Invoice in duplicate signed by the Contractor or his agent shall be sent with each delivery of materials for day-work and the Contractor will be furnished with receipt signed by the Engineer-in-charge specifying the description, quantities, weight or measurement (as the case may be) of the articles approved, reference will be made in this receipt in the return aforesaid and the Contractor's Bill.

In the case of Lumpsum Contracts, the rates to be charged and the percentage addition for profit and establishment charges etc. will be agreed upon between the Accepting Officer and the Contractor prior to the execution of the work.

### **38. Inspection of the Work**

BHEL Officers concerned with the contract shall have power at any time to inspect and examine any part of the work and the Contractor shall give such facilities as may be required to be given for such inspection and examination.

Should Engineer-in-charge consider, at any time during the expiry of the maintenance period, that any work has been executed with unsound, imperfect or unskilled workmanship or of a quality inferior to that contracted for or not otherwise in accordance with the contract (in respect). Whereof the decision of the Engineer-in-charge shall be final and conclusive the contractor shall, on demand in writing from the Engineer-in-charge specifying the fault notwithstanding that the same may have been inadvertently passed, certified and paid for, forthwith rectify or removed and reconstruct the work so specified in whole or in part as the case may require at his own expense to the entire satisfaction of the Engineer-in-charge and in the event of his failing to do so within a period to be specified by the Engineer-in-charge in his demand as aforesaid, the Engineer-in-charge whose decision shall be final and binding may carry out the work by other means at the risk and expense in all respects of the Contractor. However, the liability of the Contractor under this condition shall not extend beyond the maintenance period except as regards workmanship which the Engineer-in-charge shall have previously given notice of to the Contractor to rectify.

### **39. Responsibility for Building**

In the event of any building or part of any building being handed over to the Contractor for the execution of work there to under the provisions of the Contract he shall give a written receipt for all fixtures, glass etc., and he shall be required to make good at his own expense all damages resulting from the cause whatsoever while in his charge and on completion of the work to deliver the said building or part

thereof in a clean state complete in every particular to the entire satisfaction of the Engineer-in-charge.

#### **40. Insurance**

The Contractor shall within one month after the date of acceptance of the Contract, insure the work against loss or damages to the contract works, temporary work and materials erected in performance of the contract "all risks" basis from the time of arrival on site until taken over by BHEL on completion of the Contract.

The cover shall also include whenever necessary the risks of testing including breakdown or explosion of plant and machinery undergoing testing, trial and commissioning operations. The insurance shall also specifically cover removal of debris cost. The sum insured shall represent the estimated full value of the contract work inclusive of value of free supply materials by BHEL, transport charges, customs dues, express freight, overtime charges, cost of erection, value of constructional plants and machinery; removal of the debris and excavation of costs. Where the contract includes a maintenance period, the insurance cover shall specifically include the Contractor's liabilities during the maintenance period. The insurance shall also be extended to cover third party personal injury and property damage for a sum to be specified by BHEL. The insurance shall be effected in the name of BHEL and the Contractor shall submit to BHEL a draft of the insurance policy for approval. The policy when issued will be lodged with BHEL together with receipts of premium for such insurance and the contractor shall maintain such policies in force until the obligations of the Contractor are fully discharged.

If the Contractor fails to comply with the terms of this condition the Accepting Officer may insure the work and may deduct the amount of premiums from any money that may become payable to the Contractor or may at his discretion refuse payment of any advances to the Contractor until the Contractor shall have complied with the terms of this condition. This provision does not, however, absolve the Contractor of his responsibility for taking up the insurance. The Contractor is, therefore, primarily responsible for the insurance in time.

#### **41. Damage and Loss to Private Property and Injury to Workmen**

The Contractor shall at his own expense reinstate and make good to the satisfaction of the Engineer-in-charge and pay compensation for any injury, loss or damage occasioned to any property or rights whatever including property and rights of BHEL (or agents, servants or employees of BHEL) the injury loss or damage arising out of or in any way in connection with the execution of the contract and further the Contractor shall indemnify BHEL against all claims enforceable against BHEL or any agent, servant, or employee of BHEL a private person, in respect of any such injury (including injury resulting in death loss or damage to any person) who so ever or property, including all claims which may arise under the Workmen's Compensation Act or otherwise, or which would be enforceable against BHEL.

#### **42. Completion**

The works shall be completed to the entire satisfaction of the Engineer-in-charge and in accordance with the Contractor's forecast of Time and progress where operative, and all unused stores and materials, tools, plants equipment, temporary Building and things shall be removed from the site and work cleared of rubbish and all

waste materials and levelled up clean and tidy to the satisfaction of the Engineer-in-charge at the Contractor's expense and/or before the Schedule date of completion.

The BHEL shall have power to take over from the Contractor from time to time such sections of the Work as have been completed to the satisfaction of the Engineer-in-charge. In such an event, the contractor is not entitled for any extension of time or any other compensation for executing the balance work.

In case the Contractor fails to remove any of his properties, assets or fails to clear the rubbish and waste materials within 30 days of the completion of the contract, it is lawful for the contractee, that is BHEL to take such action as it deems fit to clear, dispose of such properties, assets or such waste materials and charge the Contractor any expenses incurred thereon.

The Engineer-in-charge shall certify to the Contractor the date on which the work is completed and the state thereof.

The Engineer-in-charge shall also certify to the Contractor the state of the work at the end of maintenance period, where applicable.

#### 43. Compensation for delay

If the Contractor fails to maintain the required progress in terms of condition 7 or to complete the work and clear the site on or before the contracted or extended period of completion, he shall, without prejudice to any other right or remedy of the BHEL on account of such breach pay as agreed compensation an amount calculated as stipulated below or such smaller amount as may be fixed by the BHEL on the contract value of the work for every week that the progress remains below that specified in condition 7 or that the work remains incomplete.

This will also to items or groups of items for which separate period of completion has been specified.

For the purpose the term "Contract Value" shall be the value at contract rates of the work or ordered.

- |  |                        |
|--|------------------------|
| a) Completion period (as originally stipulated) not exceeding 6 months                       | at 1 per cent per week |
| b) Completion period (as originally stipulated) exceeding 6 months and not exceeding 2 Years | at ½ per cent per week |
| c) Completion period (as originally stipulated) exceeding 2 years                            | at ¼ per cent per week |

Provided always that the total amount of compensation for delay to be paid under this condition shall not exceed the under noted percentage of the contract value or of the item or group of items of work for which a separate period of completion is given :

- |   |             |
|---|-------------|
| a) <sup>Completion</sup> <del>Complete</del> period (as originally stipulated) not exceeding 6 months | 10 per cent |
|---|-------------|

- |  |             |
|--|-------------|
| b) Completion period (as originally stipulated) exceeding 6 months and not exceeding 2 Years | 7½ per cent |
| c) Completion period (as originally stipulated) exceeding 2 years                            | 5 per cent  |

The amount of compensation may be adjusted or set-off against any sum payable to the contractor under this or any other contract with the BHEL.

#### **44. Laws Governing the Contract**

This Contract shall be governed by the Indian Laws for the time being in force.

#### **45. Cancellation of Contract for Corrupt Acts**

The Accepting Officer, whose decision shall be final and conclusive, shall without prejudice to any other right or remedy which shall have accrued or shall accrue thereafter to Bharat Heavy Electricals Limited, cancel the Contract in any of the following cases and the contractor shall be liable to make payment to BHEL for any loss or damage resulting from any such cancellation for default. If the Contractor shall :

- a) Offer or give or agree to give to any person in BHEL service any gift or consideration of any kind as an inducement or reward for doing or for bearing to do or for having done or forborne to do a day act in relation to the obtaining or execution of this or any other contract for BHEL service OR
- b) Enter into a contract with BHEL in connection with which commission has been paid or agreed to be paid by him or with his knowledge, unless the particulars of any such commission and the terms of payment thereof have previously been disclosed in writing to the Accepting Officer, OR
- c) Obtain a contract with BHEL as a result of ring tendering or by non-bonafide methods of competitive tendering without first disclosing the fact in writing to the Accepting Officer.

#### **46. Cancellation of Contract for Insolvency, Assignment or Transfer or Sub-Letting of Contract**

The Accepting Officer, without prejudice to any other or remedy which shall accrue thereafter to BHEL shall cancel the contract in any of the following cases :

If the Contractor

- a) being an individual, or if a firm any partner thereof shall at any time be adjudged bankrupt or have a receiving order or orders for administration, of his Estate made against him or shall take and proceedings, for liquidation or composition under any Bankruptcy Act for the time being in force or make any conveyance of assignment of his effects composition or arrangement for the benefit of his credit or purport to do so, or if any application be made under any Bankruptcy Act for the time being in force for sequestration of his Estate or if a trust deed be granted by him on behalf of his creditors, OR

- b) being a company shall pass a resolution or the court shall make an order for the liquidation of its affairs, or a Receiver or Manager on behalf of the debentures holders shall be appointed or circumstances shall arise which entitle the court or debentures holders to appoint a Receiver or Manager OR
- c) assigns, transfer, sub-lets or attempts to assign, transfer or sub-let any portion of the work without the prior written approval of the Accepting Officer OR
- d) Shall suffer an execution being levied on his goods and allow it to be continued for a period of 21 days.

Whenever the Accepting Officer, exercises his authority to cancel the contract under this condition, he may complete the work by any means at the Contractor's risk and expense provided always to that in the event of the cost of completion (as certified by Engineer-in-charge which is final and conclusive) being less than the contract cost, the advantage shall accrue to the BHEL and that if the cost of completion exceeds the moneys due to the Contractor under the contract, the contractor shall either pay the excess amount ordered by the Engineer-in-charge or the same shall be recovered from the Contractor by other means.

Engineer-in-charge will have powers to take possession of the site and any materials constructional plant, implements, stores, etc. thereon and carry out the work by any means at the risk and cost of the Contractor.

In case the BHEL completes the work under the provisions of this condition the cost of such completion to be taken into account in determining the excess cost to be charged to the contractor under this condition shall consist of the cost of materials purchased and or labour provided by the BHEL with an addition of such percentage or cover superintendence and establishment charges as may be decided by the General Manager whose decision shall be final and conclusive.

In the Contractor fails to pay the excess sum within a period of 30 days, the Engineer-in-charge shall have the right to sell any or all of the Contractor's unused materials, constructional plant implements, temporary buildings etc. and apply the proceeds of sale thereof towards the satisfaction of any sum due from the Contractor under the contract and if thereafter be any balance outstanding from the Contractor, it shall be recovered in accordance with the provisions of the Contract.

#### **47. Cancellation of contract in part or Full for Contractor's Default**

If the contractor :

- a) makes default in commencing the work within a reasonable time from the date of handing over of the site and continue in that state a reasonable notice from Engineer-in-charge OR
- b) in the opinion of the Engineer-in-charge at any time, whether before or after the date extended date for completion, make default in proceeding with the work, with due diligence and continue in the state after a notice of seven days from Engineer-in-charge OR
- c) fails to comply with any of the terms and conditions of the contract or after 7 days notice in writing with orders properly issued thereunder. OR

- d) fails to complete the work order and items of work individual dates for completion and clear the site on or before the date of completion or fails to achieve the progress at set out under clause 7 of these General conditions of contract.

The Accepting Officer may, prejudice to any other right or remedy which shall have accrued or shall accrue after B H E L, Cancel the contract as a whole or in part there or only such work order items of work in default from the contract. Whenever the Accepting officer exercises his authority to cancel the contract as a whole or in part under this condition he may complete the work at the contractor's risk and cost provided always that in the event of the cost of completion (as certified by Engineer-in-charge which is final and conclusive) being less than the contract cost the advantage shall accrue to the BHEL if the cost of completion exceeds, the money due to the contractor under this contract the contractor shall either pay the excess amount ordered by General Manager or the same shall be recovered from the contractor by other means. Engineer-in-charge will have power to take possession of site and materials, constructional plant, implements, stores etc there on.

In case the BHEL completes the work or any part there of under the provisions of the condition the of such completion to be taken in to account in determining the excess cost to be charged to the contract under this condition shall consist of the cost of materials purchased and / or labour provided by the BHEL. with an addition of such percentage to cover superintendance and establishment charges as may be decided by the General Manager whose decision shall be final and conclusive.

If the contract fails to pay the excess sum within a period of 30 days the Engineer-in-charge shall have the right to sell any or of the contractor's unused materials, construction plant, implements, temporary buildings etc and apply the proceeds of sale there of towards the satisfaction of any sum due from the contractor under the contract and if <sup>there</sup> ~~not~~ after be any balance out-standing from the contract, it shall be recovered in accordance with the provisions of the contract.

#### 48. Termination of Contract for death

Without prejudice to any of the rights or remedies under this contract. if the contractor dies, the Accepting officer shall have the option of terminating the contract without compensation to the contractor.

#### 49. Special Powers of Determination

If at any time after the acceptance of the tender BHEL shall for any reason whatsoever not require the whole or any part of the work to be <sup>carried out</sup> ~~done~~ General Manager shall give notice in writing of the fact to the contractor who shall have no claim to any payment of compensation or otherwise howsoever on account of any profit or advantage which he might have derived from the execution of the work in full but which he <sup>did</sup> ~~did~~ not derive in consequence of the foreclosing of the work.

He shall be paid at contract rates for the full amount of the executed including such additional works, e, g. clearing of site, etc., as may be rendered necessary by the said foreclosing. He shall also be allowed a reasonable payment (as decided by the Accepting office) for any expenses sustained on account of labour and materials collected but which could not be utilised on the work, as verified by the Engineer-in-charge. Neither shall the contractor have any claim for compensation on account of any alterations have been made in the original specifications drawings, designs and instructions, involving any curtailment of the work as original contemplated.

**50. BLANK**

## CHAPTER - IV

### VALUATION AND PAYMENT

#### 5). Records and Measurements :

All items having a financial value shall be entered in the BHEL Measurement Book so that a complete record is obtained of all works performed under the contract.

Buildings, etc., priced in schedule 'A' as a unit Lump-sum will be entered by number at the unit Lump-sum.

Work carried out for agreed Lump-sum will be described and similarly recorded.

Lump-sum omissions will be entered for deduction. Measurement shall be restricted to that required to ascertain the financial liability of BHEL under the contract.

Work which fails to be measured in detail shall be measured physically, without reference to any local custom that may obtain excepting where it may otherwise be directed in the tender documents. The measurements shall be taken jointly by any person duly authorised on the part of the BHEL and by the contractor.

The engineer-in-charge shall give reasonable notice in writing to the contractor of appointment of measurement.

The contractor shall without extra charge provide assistance with appliance and other things necessary for measurement.

The contractor shall bear all the cost of measurements of his work.

Measurements shall be entered in the BHEL measurement book and signed and dated by both parties each day at the site on completion of measurement. If the contractor objects to any of the measurements recorded on behalf of the BHEL, a note to that effect to be made in the BHEL measurement book or against the item or items objected to; and such note shall be signed and dated by both the parties engaged in taking the measurement.

If as a result of such objection, it becomes necessary to re-measure the work wholly or in part, the expense of such measurement shall be borne by the party requiring the measurement.

Measurement to be re-taken provided that a net error is found by this re-measurement to amount to less than 5% (Five percent) of the value as recorded by the first measurement. But where the net errors amount to 5% and over of the said value, then the cost is to be borne by the other party. In any case if the net value of errors found exceeded to Rs 500 the expense or re-measurement is said to be borne by the other party. If the contractor's representative fails to attend when required, the engineer-in-charge shall have power to proceed by himself to take measurement and in that case those measurements shall be considered as accepted by the contractor as final. The contractor shall, once in every month, submit to the engineer-in-charge with a copy to the accepting officer details of his claims for the work done by him up to and including the previous month which are not covered by his contract agreement in any of the following respects.

- a) Deviation from the items and specifications provided in the contract documents.
- b) Extra Items / Items of work.
- c) Quantities in excess of those provided in the contract schedule.
- d) Items in respect of which rates have not been settled. He should, in addition furnish a clear certificate to the effect that the claims submitted by him as aforesaid cover all his claims and that no further claims shall be raised by him in respect of work done up to and including the period under report.

Except where any general to detailed description of the work in quantities expressly shows to contrary, schedule of quantities shall be deemed to have been prepared and measurements shall be taken in accordance with the procedure set forth in the schedule of rates specification not withstanding any provision in the relevant standard method of measurement or any general or local custom. In the case of items which are not covered by the schedule of rates / specification, measurement shall be taken in accordance with relevant standard method of measurement issued by the Indian Standard Institution or as per Standard engineering practice.

## **52 Valuation of Deviations**

Rates for deviated items of work will be fixed as follows :

- 1) For any item of work required to be carried out after the contract has been awarded and which is not covered by Contractor's Schedule but is covered by B.H.E.L. schedule of Rates the payable for such a fresh item will be derived from B.H.E.L. Schedule by the method of proportion as follows:
  - a) In the same proportion to the BHEL Schedule of rates as the tendered rate for the nearest analogous item of work in contractor's schedule bears to rate for the particular analogous item of work in BHEL schedule of rates. However in case of nearest analogous item of work in contract schedule forms part of individual chapter of the BHEL schedule of rates the above proportion will be worked out only for such items which are found both in contract schedule and BHEL Schedule of rates as group of items under the chapter.
  - b) If a single appropriate analogous item of work is not available in both schedule (contractor's and BHEL schedule) then the method of proportion will be applied to the nearest analogous group items available in both the schedule referred to i.e. in the same proportion as the total tendered cost of that particular group of item (the sum of the products of the tendered rates and the quantities for which orders are placed ) bears to the total cost of the same items and quantities and BHEL Schedule of Rates.
  - c) If even an appropriate analogous group of items is not available in contractor's schedule and BHEL Schedule, then the methods of proportion will be applied to all those items of the whole work, which are available in both the schedule and for which orders have been placed on the contractor i. e., in the same proportion as the total cost of all

these items of work (the work of the products of the tendered rates and the quantities for which order are placed) bears to the total cost of the same items and quantities at the BHEL schedule of rates.

The selection of analogous items or analogous group of items referred to above shall be done by the Engineer-in-charge. Where the rates for deviated items or new items of work can be derived by the selection of different analogous items or analogous group of items, the lowest of all such derived rates shall be taken as the correct rate.

In the case of the contracts for which the Engineer-in-charge is the Accepting officer all disputes regarding the settlement of rates of deviated or new items or work shall be referred to the Head of Civil Engineering Department whose decision shall be final and conclusive as the case may be.

II. If any work not covered by any of the foregoing is ordered of the contractor, the basis of payment shall be decided by the Accepting Officer whose decision shall be final and conclusive and binding on the parties.

### **53. Reimbursement / Refund on variation in Price, Materials**

If after submission of the tender and / or during the progress of the works, the price of any material (not being a material supplied from the BHEL store in accordance with the conditions of the contract) is increased or decreased by an Act of Legislature (central or state) and / or any notification thereunder or on account of new duties or levies such as octroi or on account of increase or decrease in such duties affecting the price of materials required for incorporation in the works and made from materials of which the price has increased or decreased as aforesaid and the contractor has thereupon to pay in respect of such material or item a price which is higher or lower than the price of that material or item as prevailing immediately before the passing of such act or levying, increasing / decreasing of such duty, the BHEL shall increase in price or the duty reimbursed to the contractor the increase in price or additional or increased duty paid by the contractor and in case of decrease in price the BHEL shall be entitled to a refund of the reduction in the price or the reduction in duty. This will be applicable only for material which are directly incorporated on the work. The contractor shall however indicate the assumption he has made while submitting the tender. However no reimbursement or refund shall be made if the increase / decrease is not more than + 10% of the said price, and if so the reimbursement or refund shall be made only / on the excess over  $\pm$  10% provide always that any such increase shall not be payable if, in the opinion of the Accepting officer (whose decision shall be final and conclusive) the increase is attributable to the delay in the execution of the contract with the control of the contractor or that any such increase has become operative after the contracted/ or extended date of completion of the works or items of work in question.

The Contractor shall, for the purpose of this condition, keep such books of account and other documents as are necessary to show the amount of any increase or any reduction available and shall allow inspection of the same by any duly authorised representative of the BHEL and further shall at the request of the Engineer-in-charge furnish for verification such other information as the Engineer-in-charge may require.

The Contractor shall within a reasonable time of his becoming, aware of any alteration in the prices of any such materials give notice thereof in writing to the Engineer-in-charge stating that the rate is submitted in pursuance to this condition together with all information relating thereto which he may be in a position to supply.

#### **Advance on account**

No payment shall be made for work estimated to cost less than Rupees ONE THOUSAND till after the whole of the work shall have been completed and a certificate of completion given by the Competent authority.

In the case of work estimated to cost more than Rupees FIVE THOUSAND the contractor may at intervals of less than one month or as otherwise provided for in the Contract documents, counting from the date on which order to commence work is given by Engineer-in-charge submit claims on BHEL forms for payment of advances on account of work done and of materials delivered in connection with the Contract.

The Contractor shall be paid in respect of such claims to the extent approved and passed by the Engineer-in-charge subject to a maximum of 90% of the value of the work actually executed to the satisfaction of the Engineer-in-charge. The certificate of the Engineer-in-charge regarding such approval and passing of the sums so payable shall be final and conclusive against the contractor.

#### **Notes :**

"After the full amount of Security Deposit is made up through the 10% deduction from On account bills, 100% payment of all subsequent bills may be made to the contractor.

The Contractor may also be paid during the progress of the work 75% of the value of any materials which are in the opinion of the Engineer-in-charge in accordance with the Contract, and are actually required for incorporation in the work and which have reasonably been brought to the site in connection therewith and are adequately stored and / or protected against damage by weather or other causes, but which have not at the time of payment of the advance been incorporated the work on furnishing a formal hypothecation deed. Payment of such advances, however shall be purely at the discretion of the Accepting Officer provided always that payment shall not be made under these periodical certificate in respect of materials like lime, cement, timer, sand, kankar, etc.

Any sums, due from the Contractor on account of Tools and Plant, stores or any other items provided by BHEL shall be deducted from the respective advances. The Engineer-in-charge shall from time to time certify the sums payable to the Contractor after retaining the reserves.

Any certificate relating to work done or materials delivered may be modified or corrected by any subsequent interim certificate or by the final certificate of the Engineer-in-charge supporting an advance payment shall itself be conclusive evidence that any any work or materials it relates are in accordance with the contract. All such intermediate payments shall be regarded as advance against the final payment only and shall not be considered an admission of the performance of the contract or any part thereof in any respect or the accruing of any claim whatsoever.

Such intermediate payment shall not conclude determine or affect in any way the powers of the Engineer-in-charge as to the final settlement and adjustment or the account or otherwise or in any way vary or affect the contract.

#### **55. Final Bill**

As soon as possible after the completion of the work to the satisfaction of the Engineer-in-charge, the contract shall forward a certified final account on BHEL forms, in duplicate.

It shall be accompanied by all abstracts, vouchers, etc., in support thereof and shall be prepared in the manner prescribed by the Engineer-in-charge.

No claims will be entertained after the receipt of the final bill.

The Contractor shall be entitled to be paid the final sum less the value of payments already made on account, subject to certification of the final bill by the Engineer-in-charge. Any sums due from the Contractor on account of Tools and Plant, Stores or any other items provided by BHEL not yet recovered from the contractor shall be deducted from the final sum aforesaid.

No charge shall be allowed to the Contractor on account of the preparation of the final bill.

#### **56. Payment of Bills**

All payment to be made to the Contractor under this contract shall be by "Crossed Cheque" marked "A/c payee only" (within a reasonable time after the certification by the Engineer-in-charge) at the Nationalised Banks/Scheduled banks or their subsidiaries located in the station where either the work is executed or service rendered or at their branch nearest to the station where the Office of the Engineer-in-charge is located.

#### **57. Recovery from Contractor**

Whenever under the contract any sum of money shall be recovered from or payable by the Contractor the same may be deducted any sum then due or which at any time thereafter may become due to the Contractor under the contract or under any other contract with BHEL or from his Security Deposit or he shall pay the claim on demand.

#### **58. Post Technical Audit of work and Bills**

BHEL reserve the right to carry out a post-payment audit and technical examination of the work and final bill including all supporting vouchers, abstracts etc., and to enforce recovery of any sums becoming due as a result thereof in the manner provided in the preceding sub-paragraphs provided. However, no such recovery shall be enforced after three years of passing the final bill.

#### **59. Refund of Security Deposit**

50% of the Security deposit mentioned in condition 18 above, may be refunded to the Contractor in respect of all contract on completion of work and after payment of final bill and the balance 50% on expiry of the maintenance period, provided the

Contractor shall have rendered a "No - Demand" Certificate. In case of work where maintenance period is not involved 100% of the Security Deposit may be refunded after payment or final bill provided that the Contractor shall have rendered a "No Demand" Certificate.

## **60. Arbitration**

Except where otherwise provided for in the contract all questions and disputes relating to the meaning of the specifications, designs, drawings and Instructions herein before mentioned and as to the quality of workmanship or materials used on the work or as to any other question, claim matter or thing whatsoever in any way arising out of or relating to the contract, designs, drawings, specifications, estimates, instructions, orders or there conditions or otherwise concerning the work or failure to execute the same whether arising during the progress of the work or after the completion or abandonment thereof shall be referred to the sole arbitration of the General Manager of BHEL and if General Manager is unable or unwilling to act, to the sole arbitration of same other persons appointed by the General Manager, willing to act as such arbitrator.

The cases referred to arbitration shall be other than those for which the decision of the Accepting Officer, or Engineer-in-charge as the case may be, is expressed in the contract to be final and conclusive. There will be no objection if the arbitration, so appointed is an employee of BHEL and that he had to deal with the matters to which the contract relates and that in the course of his duties as such he had expressed views on all or any of the matters in dispute or difference.

The arbitrator to whom the matter is originally referred being transferred or vacating his office or being unable to act for any reason, such General Manager as aforesaid at the time of such transfer, vacation of office or inability to act, shall appoint another person to act as arbitrator in accordance with the terms of the contract. Such person shall be entitled to proceed with the reference from the stage at which it was left by his predecessor.

Subject as aforesaid the provision of the Arbitration Act, 1940 or any statutory modification or re-enactment thereof and the rules made thereunder and for the time being in force shall apply to the arbitration proceeding under this clause.

It is a term of the contract that the party involving arbitration shall specify the dispute or disputes to be referred to arbitration under this clause together with the amount or amount claimed in respect of each dispute.

The arbitrator(s) may from time to time with consent of the parties enlarge the time, for making and publishing the award.

The work under the Contractor shall if reasonably possible continue, during the arbitration proceedings and no payment due or payable to the Contractor shall be withheld on account of such proceedings.

The Arbitrator shall be deemed to have entered on the reference on the date he issues notices to both the parties fixing the date of first hearing.

The Arbitration shall give a separate award in respect of each dispute or difference referred to him.

The venue of arbitration shall be such place as may be fixed by the Arbitrator in his sole discretion.

The award of the Arbitration shall be final, conclusive and binding on all parties to this contract.

In the event of disputes or differences arising between one public sector enterprise and a Govt. Department or between two public sector enterprises the above stipulations shall not apply, the provisions of BPF Office memorandum No. BPF/CL001/76MAN/2(1.10) 75 - BPE (GM - 1) dated 1st January 1976 or its amendments for arbitration shall be applicable.

**61. Jurisdiction of Court**

For the purpose of Court proceeding if any, same shall be in the Court having jurisdiction over Ranipet - 632 406. (Vellore District, Tamilnadu).

**62. Taxes etc. -**

All taxes, duties, levies that are payable to the Government or to any other authorities in respect of the works under the contractor at the time of contract or becomes payable in future shall be exclusively borne by the contractor and the BHEL is not liable for any reimbursement / Payment thereof.

## ANNEXURE - I

### TERMS AND CONDITIONS REGARDING COMPLIANCE WITH VARIOUS LABOUR LAWS BY THE CONTRACTORS FOR BHEL

{Please See Condition - 22}

1. The Contractor shall not employ in connection with the work any person who has not completed 18 years of age.
2. The Contractor shall in respect of labour employed by him either directly or through sub-contractor's comply with or cause to be complied with the following statutory provisions and rules and in regard to all matters provided therein.
  - a) The Contract Labour (Regulation & Abolition) Act 1970 and the related Tamilnadu rules.
  - b) The Minimum wages Act 1948 and the related Tamilnadu Rules.
  - c) The payment of wages Act 1936 and the related Tamilnadu Rules.
  - d) The factories Act 1948 and teh related Tamilnadu Rules.
  - e) The Employees' Provident Fund & Miscellaneous Provisions Act 1952.
  - f) The Employees State Insurance Act 1948.
  - g) The workman's Compensation Act 1923.
  - h) The Industrial Disputes Act 1947 and any other Law or modifications to the above or to the rules made there under from time to time.
  - i) Paymet of Bonus Act 1985.

#### REGISTRATION AND LICENSING

3. Every Contractor shall register his name with the Welfare Section of BHEL before taking up the work awarded to him by giving the following information and getting a code Number :-
  - a) The Name of the Contractor.
  - b) Nature of Contract Work.
  - c) Period of Work.
  - d) Number of maximum labour employed by him on anyone day.
  - e) Licence No. & Date (applicable in case of Contractors employing 20 or moreworkers)
  - f) Whether enrolled for PF, ESI, etc., and enrolment No.

This information is called for the purpose of informing the Inspectorate of Factories whenever they call for information regarding Contracts.

4. The Contractor employing 20 or more workmen is required to obtain licence from the authorities (The Deputy Chief Inspector of Factories / Assistant Commissioner of Labour as the case may be). This licence shall be amended and /or renewed wherever there is an increase in the workmen employed by him or in the event of contract being extended or renewed. The Contractor shall inform the licence number to the BHEL Management before taking up the work.
5. The Contractor (licensed or unlicensed) shall promptly furnish every information and document required by BHEL authorities for the purpose of fulfilling their obligations as principal Employer and / or occupier of the factory and shall render all necessary assistance for the same.

#### **WAGES**

6. The Contractor shall pay wages to the workmen employed by him at the rate which shall not be less than the minimum wages applicable under Law from time to time.
7. The Contractor shall fix wage periods in respect of which wages shall be payable. No wage period shall exceed one month.
8. The Contractor shall ensure payment of wages to the Contract labour employed by him within three days from the end of wage period in case the wage period, is one week or a fortnight and in all other cases before 10th day of the following month.
9. All payment of wages shall be made on working days at the work site and during the working time and on dates notified in advance. In case the work is completed before the expiry of the wage period, final payment shall be made within 48 hours of the last working day.
10. Where the employment of any works is terminated by or on behalf of the Contractor, the wages earned by him shall be paid before the expiry of the second working day from the day on which his employment is terminated.
11. Wages due to every worker shall be paid to him direct or to the person authorities by him in this behalf. All wages shall be paid in current coin or currency or in both.
12. The Contractor shall ensure the disbursement of wages in the presence of such authorised representatives of BHEL Management.
13. The above payment shall be verified by the authorised Officers/ representative of BHEL with the following certificates on the payment sheet  
 Certified that the amount shown in Column No..... has been paid to the workmen concerned in my presence on..... at .....
14. A certificate of payment shall be furnished in duplicate by the Contractor to the Engineer-in-charge each month in Form "A" enclosed.

15. A Notice of showing the wage period and the place and time of disbursement of wages shall be displayed at the place of work and a copy to be sent to the welfare department by the Contractor under acknowledgement.
16. Notices showing the rates of wages, weekly rest days, wage period, hours of work, date of payment of wages, and addressed of the Inspectors having jurisdiction the date of unpaid wages shall be displayed in Tamil and English in conspicuous places at the establishment and at worksite the contractor. The contractor shall inform the BHEL Management every month the details of contract labour engaged for each contract in the following form :-
  - a) Serial Number
  - b) Location
  - c) Period of Work
  - d) No. of Contract labour engaged during the work
  - e) No. of days worked
  - f) No. of Mandays worked
  - g) Wages paid to his workers

The above statement shall be furnished to BHEL Management at the end of every month.

#### **REGISTERS AND RECORDS AND COLLECTION OF STATISTICS**

17. The following documents/formats under contract labour (Regulation and Abolition) Act 1970 and Tamil Nadu Rules there under shall be maintained by each Contractor.
  - a) Register of Persons employed by the Contractor.
  - b) Employment Card
  - c) Service Certificate
  - d) Muster Roll, Wage Register, Deduction Register, Wage Slip, Over Time Register, Register of Fines, Register of Advances etc.
18. The Contractor shall display the abstract of the contract labour (Regulation and Abolition) Act and the Rules there under both in English and in Tamil.
19. Half Yearly Return shall be sent by the Contractor in duplicate to the Licensing Officer.
20. The Contractor shall submit the returns required under the Contract Labour (Regulation and Abolition) Act 1970 periodically to BHEL Management.
21. The Contractor shall without fail give upto date information in writing of the attendance of the workers employed by him.

22. The Contractor shall ensure that his workers keep and produce their Employment Card when coming to duty and take them back when leaving duty.
23. All the above registers and records shall be preserved in original for a period of Three years. All the Registers, Records and notice maintained under the Act and rules shall be produced on demand by Inspector or any authority under the Act.

#### **WORKING HOURS AND WORKING CONDITIONS**

24. NO WORKER SHALL BE REQUIRED OR ALLOWED TO WORK ON SUNDAY UNLESS HE HAS OR WILL HAVE A HOLIDAY ON ANYONE OF THE THREE DAYS BEFORE OR AFTER THE SAID DAY.
25. The contractor shall inform BHEL Management in the prescribed form details of the contract workers scheduled to work on Sunday, the day of rest and also indicate the substituted holiday in lieu thereof. This shall be intimated two days in advance before his workmen are booked for work on Sunday.
26. The contract labour working for more than nine hours in any day or for more than 48 hours in any week shall be paid wages at the rate of twice the ordinary rates of wages in accordance with the provisions of section 59 of the factories Act 1948
27. The contractor shall provide all safety devices and personal protective equipment to his workmen at his own cost and shall ensure that his workmen wear/use such devices or equipment provided to them while doing the work and there should not be any relaxation on this.
28. The contractor shall give four paid National Holidays to his workers, viz. 26th January, 1st May, 15th August and 2nd October.
29. The contractor shall ensure that his workmen vacate the premises after the shift is over.
30. No woman worker shall be required or allowed to work in the factory except between the hours of 6.00 a.m and 7.00 p.m
31. The contractor shall comply with the provisions relating to welfare and Health facilities as provided in the contract labour ( Regulation and Abolition ) Act 1970 read with the Tamilnadu contract labour Rules 1975.

#### **NOTICES OF ACCIDENTS**

32. Notwithstanding any thing contrary to this , in the event of accident the contractor shall be required to fill injury report and submit the Engineer-in-charge immediately and ensure the compliance of ESI/Workmen's Compensation Act, Factories Act and Rules made there under. He shall also maintain a register of accident as per Act.
33. The contractor shall get the contract labour engaged by him insured under workmen's Compensation Policy from General Insurance Corporation of India before actually starting the work of contract. The Insurance coverage should

be for the entire period of contract. The contractor shall comply with the provision of the Workmen's Compensation Act 1923 [This should be read in conjunction with the provision of ESI Act]

34. The contractor shall ensure that all his workmen are covered under the Employees State Insurance Act and produce to BHEL such Registration Number/ Enrolment Number before executing the contract work.
35. The contractor shall regularly pay the amount of contribution i.e. employers contribution as well as employees contribution in pursuance of the above scheme as fixed from time to time. The contribution payable presently is 1.75% of wages to be recovered from the workmen and 4.75% of wages to be contributed by the contractor. Contribution recovered from employee and contribution made by the contractor may be rounded to the next higher multiples of five paise.
36. The contractor shall take note of any amendment that may be brought forth in the above contribution rate and accordingly.
37. The contractor shall ensure that his workmen are covered under the EPF & miscellaneous Provision Act 1952 and accordingly produce to the BHEL Management the registration / enrolment number before awarding of contract work. As per the existing provision every worker who has completed three months continuous service or has actually worked for not less than 60 days within a period of three months or less shall be entitled and required to become a member of the fund. The employees' contribution payable at present is 12% of wage which will be recovered by the contractor from the wages of his workmen and the contractor should pay equal contribution. The contractor is also liable to pay any administrative charges in this behalf that may be decided from time to time, it will be the responsibility of the contractor to ensure such contribution payable in respect of workmen employed through sub-contractors also.
38. The contractor shall take note of any amendment in the rate of contribution payable under the scheme from time to time.
39. The contractor shall within seven days of the close of every month submit to BHEL a statement showing the amount of contribution payable/paid for employees engaged by him or through him and shall also furnish to BHEL such information as Principal Employer is required to furnish under the provision of the ESI Act and PF as well as the schemes made thereunder to the authorities concerned.
40. Whenever any sum of money is found to be recoverable from or payable by the contractor under the above Acts the same shall be deducted from any sum that may be due or which at any time thereafter may become due to the contractor under this contract or under any other contract or from his security deposit in case the recoveries are not sufficient to satisfy the claims, the contractor shall pay the balance thereof on demand. In case any recoveries are made this clause shall as may be required to replace the shortage caused by such recoveries in the amount of Security Deposit.

41. The contractor shall abide by all the labour and other laws applicable to contract:labour/worken under this contract and shall at all times keep BHEL Indemnified against all losses, claims, prosecutions under any law.
42. in case of non compliance of any of the provisions of the Acts and in case BHEL Haveing complied with the same BHEL will be entitled to recover the same from the contractor / sub contractor.
43. Non exercise of any of the power of or rights available to BHEL here under or under any law, shall not any way operate as waiver thereof.

ACCEPTING OFFICER

**FORM - IV**

**(See Rule 21(1) of Tamil Nadu Contract Labour Rules)**

**Application for Licence**

01. Name and Address of the Contractor  
(including his Father's Name in case of  
Individuals) :
02. Date of Birth and age (in case of  
Individuals) :
03. Particulars of Establishment where  
Contract Labour is to be employed :
- a) Name and Address of the  
Establishment :
- b) Type of business, trade industry  
manufacture :
- c) Number and date of certificate of  
Registration of occupation, which is  
carried on the Establishment under  
the Act. :
- d) Name and address of the Principal  
Employer :
04. Particulars of contract labour :
- a) Nature of work in which contract  
labour is employed or is to be  
employed in the establishment :
- b) Duration of the proposed contract  
work (give particulars of proposed  
date of commencing and ending) :
- c) Name and address of the agent or  
Manager of contractor at the worksite :
- d) Maximum No. of contract labour  
proposed to be employed in the  
establishment on any date :

- 05. Whether the contractor was convicted of any offence within the preceeding five years, if so give details :
- 06. Whether there was any order against the contractor revoking or suspending licence or forfeiting security deposit in respect of an earlier contract if so the date of such order :
- 07. Whether the contractor has worked in any other establishment within the past five years, if so, give details of the principal employer Establishment and nature of work :
- 08. whether a certificate by the principal Employer in form V is enclosed :
- 09. Amount of licence fee paid No of Treasury challan and Date :
- 10. Particulars of security deposit if any, requested to be adjusted, including Treasury Receipt number :
- 11. The amount of security deposit or balance if any after adjustment of amount to be refunded under rule 31 deposited with treasury Receipt Number and date :

**DECLARATION**

I hereby declare that the details above are correct to the best of my knowledge and belief.

**PLACE :**  
**DATED :**

**SIGNATURE OF THE APPLICANT**  
**[CONTRACTOR]**

**NOTE :** The application should be accompanied by a treasury Receipt for the appropriate amount and a certificate in Form V From the principal employer.

(To be filled in the office of the Licensing officer)

Date of receipt of the application with challan for fees / security Deposit.

**SIGNATURE OF THE LICENSING OFFICER**

**CONTRACTOR**

**FORM - XIII**

**(See Rule 75 of Tamil Nadu Contract Labour Rules 1975)**

**Register of workman employed by contractor**

Name and Address of the Contractor :

Name and location of work :

Name and address of establishment in /under  
which contract is carried on :

Name and address of Principal Employer :

01. Serial Number :

02. Name and surname of workman :

03. Age and sex :

04. Father's / Husband's Name :

05. Nature of Employment /Designation :

06. Permanent Home address of workman  
( village Taluk and District ) :

07. Local Addresss :

08. Date of commencement of Employment :

09. Signature or Thump Impression of workman :

10. Date of termination of Employment :

**CONTRACTOR**

**FORM - XIV**

**(See Rule 76 of Tamil Nadu Contract Labour Rules)**

**EMPLOYMENT CARD**

Name and Address of contractor : Name and address of  
Establishment in/under which  
contract is  
carried on \_\_\_\_\_  
\_\_\_\_\_

Nature of work and location of work : Name and address of  
Principal Employer  
\_\_\_\_\_

01. Name of the workmen :

02. Sl. No. of register of workmen employed :

03. Name of Employment/Designation :

04. Wage rate (with particulars of unit in case of  
Piece work) :

05. Wage period :

06. Tenure of Employment :

07. Remarks :

**SIGNATURE OF CONTRACTOR**

**CONTRACTOR**

FORM - XV

{See Rule 77 of Tamil Nadu Contract Labour Rules}

**SERVICE CERTIFICATE**

Name and Address of the contractor : Name and address of  
Establishment in/under which  
contract is  
carried on \_\_\_\_\_  
\_\_\_\_\_

Name and location of the work :

Name and address of the workman : Name and address of Principal  
Employer  
\_\_\_\_\_

Age or Date of Birth :

Identification marks :

Father's / Husband's Name :

Sl.No	Total period for which employed		Nature of work done		Rate of wage (with particulars units in case of piece of work	Remarks
	From	To	(4)	(5)		
(1)	(2)	(3)	(4)	(5)	(6)	(7)

**SIGNATURE**

CONTRACTOR

**FORM - XVI**

(See Rule 78 [1] [a] [i] of Tamil Nadu Contract Labour Rules)

**MUSTER ROLL**

Name and Address of contractor

: Name and address of  
Establishment in/under which  
contract is  
carried on \_\_\_\_\_  
\_\_\_\_\_

Nature of location of the work

: Name and address of  
Principal Employer \_\_\_\_\_

For the Month of \_\_\_\_\_

Sl. No	Name of workmen	Father's/Husbands Name	Sex	Dates					Remarks	
				1	2	3	4	5		
(01)	(02)	(03)	(04)	(05)	(06)					

**SIGNATURE OF CONTRACTOR**

**CONTRACTOR**

**FORM - XVII**

**(See Rule 78(1) (a) (i) of Tamil Nadu Contract Labour Rules)**

**Register of wages**

Name and Address of the Contractor :

Nature and location of work :

Name and address of establishment in/under  
which contractor is carried on :

Name and address of Principal Employer :

Wage Period : MONTHLY

01. Serial Number :

02. Name of workman :

03. Sl. No. in Register of workman :

04. Designation / Nature of work done :

05. No. of days worked :

06. Units work done :

07. Daily rate of wages / Piece rate :

08. Basic wages :

09. Dearness allowance :

10. Overtime :

11. Other cash Payment  
(Nature of payment to be indicated ) :

12. Total :

13. Deductions, If any [indicate nature ] :

14. Net amount paid :

15. Signature / Thumb impresion of workman :

16. Initials of contractor or his representative :

**CONTRACTOR**

**FORM - XIX**

(See Rule 78(1) (b) of Tamil Nadu Contract Labour Rules)

**Wage Slip**

Name and Address of the Contractor : Name and Father's /  
Husband Name of the  
workman \_\_\_\_\_

Name and location of work : For the week / Fortnight /  
Month ending .....

01. No. of days worked :

02. No. of units worked in  
case of piece rate workers :

03. Rate of daily wages /piece rate :

04. Amount of over time wages :

05. Gross wages Payable :

06. Deductions, if any :

07. Net amount of wages paid :

**INITIALS OF THE CONTRACTOR OR  
HIS REPRESENTATIVE**

**CONTRACTOR**

FORM - XX

(See Rule 78(1) (a) (ii) of Tamil Nadu Contract Labour Rules)

Register of deductions for damage or loss

Name and Address of the Contractor :

Nature and location of work :

Name and address of establishment in/under  
which contractor is carried on :

Name and address of Principal Employer :

01. Serial Number :

02. Name of workman :

03. Father's / Husband's Name :

04. Designation / Nature of employment :

05. Particular of damage or loss :

06. Date of damage or loss :

07. Whether workman showed cause  
against deduction :

08. Name of person in which presence  
employee's explanation was heard :

09. Amount of deduction imposed :

10. No. of instalments imposed : Date of Recovery

11. First Instalments :

12. Final Instalments :

13. Remarks :

CONTRACTOR

**FORM - XXI.**

**(See Rule 78(1) (a) (ii) of Tamil Nadu Contract Labour Rules)**

**Register of Fines**

Name and Address of the Contractor :

Nature and location of work :

Name and address of establishment in/under  
which contractor is carried on :

Name and address of Principal Employer :

01. Serial Number :

02. Name of workman :

03. Father's / Husband's Name :

04. Designation / Nature of employment :

05. Act / Omission for which fine imposed :

06. Date of offence :

07. Whether workman showed cause against  
fine :

08. Name of the person in whose presence  
employee's explanation was heard :

09. Wage period & Wage payable :

10. Amount of fine imposed :

11. Date on which fine realised :

12. Remarks :

**FORM - XXII**

**(See Rule 78 (1) (a) (ii) of Tamil Nadu Contract Labour Rules)**

**Register of Advance**

- Name and Address of the Contractor :
- Nature and location of work :
- Name and address of establishment in/under  
which contractor is carried on :
- Name and address of Principal Employer :
01. Serial Number :
02. Name of workman :
03. Father's / Husband's Name :
04. Designation / Nature of employment :
05. Wage period and wages payable :
06. Date and amount of advance given :
07. Purposes (s) for which advance made :
08. No. of instalments by which advance  
to be repaid :
09. Date and amount of each instalment repaid :
10. Date on which instalment was repaid :
11. Remarks :

**CONTRACTOR**

**FORM - XXIII**

**(See Rule 78(1) (a) (iii) of Tamil Nadu Contract Labour Rules)**

**Register of Overtime**

Name and Address of the Contractor :

Nature and location of work :

Name and address of establishment in/under which contractor is carried on :

Name and address of Principal Employer :

01. Serial Number :

02. Name of workman :

03. Father's / Husband's Name :

04. Sex :

05. Designation / Nature of employment :

06. Dates on which overtime worked :

07. Total overtime worked or production in case of piece -rated :

08. Normal rate of wages :

09. Overtime rate of wages :

10. Overtime earning :

11. Date on which Overtime wages paid :

12. Remarks :

**CONTRACTOR**

# PAYMENT CERTIFICATE

## FORM "A"

Certified that :

1. I as contractor of .....  
have made payment to all contract Labourers in full in respect of contract  
No. .... as per terms of my contract  
and in no case less than the rates applicable upto the period ending.
2. The above payment have been made by me in the presence of the au-  
thorised representative of .....  
of ..... for .....  
Employees amounting to Rs .....
3. The necessary payment registers attendance register / Form 12 . Leave  
register / book under Laboure and industrial Law and other relevant records  
have been maintained by me and available with me for production as and  
when required .
4. No payment is due / outstanding to any contract Labourers engaged by  
me in respect of the aforesaid contract upto the period ending  
.....

### CONTRACTOR

NAME :  
DATE :

### SUPERVISOR

NAME :  
DESIGN :  
DATE :

COUNTERSIGNED  
OFFICER INCHARGE

NAME :  
DESIGN :  
DEPT. :

CONTRACTOR

**ANNEXUR II**  
**SAFETY RULES**  
**(See Condition 2)**

**A BHEL SAFETY CODE**

**A**

1. Suitable scaffolds shall be provided for workmen for all work that cannot safely be done from the ground, or from solid construction except such short period of work as can be done safely from ladder. When a ladder is used an extra mazdoor shall be engaged for holding the ladder and if the ladder is used for carrying materials as well suitable footholds and handholds shall be provided on the ladder and the ladder shall be give an inclination not steeper than  $\frac{1}{4}$  to 1 ( $\frac{1}{2}$  horizontal and 1 vertical)
2. Scaffolding or staging more than 3.25 metres above the ground or floor, swing or suspended from an overhead support or erected with stationary support, shall have a guard rail properly attached, bolted braced and otherwise secured atleast 1 metre high above the floor or platform of such scaffolding or staging and extending along the entire length of the outside and ends thereof with only such opening as may be necessary for the delivery of materials. Such scaffolding or staging shall be so fastened as to prevent it from swaying from the building or structure.
3. Working platform, gangways and stairways shall be so constructed that they do not sag unduly or unequally, and if height of a platform or gangway or stairway is more than 3.25 metres above ground level or floor level it shall be closely boarded, have adequate width and be suitably fenced, as described in 2 above.
4. Every opening in floor of a building or in a working platform shall be provided with suitable means to prevent fall of persons or materials by providing suitable fencing or railing with a minimum height of 1 metre.
5. Safe means of access shall be provided to all working platform and other working places. Every ladder shall be securely fixed, no portable single ladder shall be over 9 metres in length. Width between side rails in a rung ladder shall in no case be less than 30 cm for ladders upto and including 3 metres in length, For longer ladder this width shall be increased by atleast 6mm for each additional 30cm of length. Uniform step spacing shall not exceed 30cm.

Adequate precautions shall be taken to prevent danger from electrical equipment. No materials on any of the sites shall be so stacked or placed as to cause danger or inconvenience to any person or the public. The contractor shall provide all necessary fencing and light to protect public from the accident and shall be bound to bear expenses of defence of every suit-action or other proceeding at law that may be brought by any person for injury sustained owing to neglect of the above precautions, and pay any damages and cost which may be awarded in any such suit, action or proceeding to any such person or which may with the consent of the contractor be paid to compromise any claim by such person.

## 6. Excavation and Trenching

All trenches 1.5 metres or more in depth, shall at all time be supplied with atleast one ladder for each 30m length or fraction there of ladder shall be extended from bottom of trench to atleast 1 metre above surface of the ground . Sides of the trench 1.5 metres or more in depth shall be stepped back to give suitable slope or securely held by timber bracing,so as to avoid the danger of sides collapsing . Excavated materials shall not be placed within 1.5 metres of the edge of trench or half the depth of trench, whichever is more. Cutting shall be from top to bottom under no circumstances shall under mining or under - cutting be done.

## 7. Demolition :

Before any demolition work is commenced and also during the progress of work.

- a) All roads and open areas adjacent to the work site shall be closed or suitably protected .
  - b) No electric cable or apparatus which is liable to be a source of danger over a cable or apparatus used by the operator shall remain electrically charged.
  - c) All practical steps shall be taken to prevent danger to person employed from the risk of fire or explosion ,or flooding no floor , or roof or other part of building shall be so overloaded with debris or materials as to render it unsafe.
8. All necessary personal safety equipment as considered adequate by the Engineer-in-charge shall be /available for use of person employed on the site and maintained in a condition suitable for immediate use and the contractor shall take adequate steps to ensure proper use of equipment by those concerned.
- a) Workers employed on mixing asphaltic materials cement and lime mortars concrete shall be provided with protective footwear and protective gloves.
  - b) Those engaged in handling any material which is injurious to the eye shall be provided with protective goggles.
  - c) Those engaged in welding work shall be provided with welder's protective eye shells
  - d) Stone breaker shall be protective goggles and protective clothing and seated at sufficiently safe intervals.
  - e) When workers are employed in sewers and manholes which are in use , the contractor shall ensure that manhole covers are opened and manholes are ventiled atleast for an hour before the workers are allowed to get into them manholes so opened shall be cordoned off with suitable railing and provided with warning signals or boards to prevent accident to public.
    - i) No paint containing lead or lead products shall be except in the form of paste or ready-made paint.
    - ii) Suitable face masks shall be supplied for use by workers when paint applied in the form of spray or surface having lead paint is dry rubbed and scrapped .

f) The contractor shall not employ men below the age of 18 and women on the work of painting with products containing lead in any form. Whenever men above the age of 18 are employed on the work of lead painting the following precaution shall be taken :

A f i) No paint containing lead or lead products shall be used except in the form of paste or ready-made paint.

ii) Suitable face masks shall be supplied for use by workers when paint is applied in the form of spray or surface having lead paint is dry rubbed and scrapped

iii) Overalls shall be supplied by the contractor to workmen and adequate facilities shall be provided to enable working painters to wash during or cessation of work.

9. When work is done near any place where is risk of drowning ,all necessary equipment shall be provided and kept ready for use and all necessary steps taken for prompt rescue of any person in danger and adequate provision made for prompt first aid treatment of all injuries likely to be sustained during the during the course of the work.

10. Use of hoisting machine and tackles including their attachments,anchorage and support shall conform to the following

a)

i) These shall be of good mechanical construction, sound materials and adequate strength and free from defects and shall be kept in good working order.

ii) Every rope used in hoisting or lowering materials or as a means of suspension shall be of durable quality and adeuate strength and free from defects.

b) Every crane driver or hoisting appliance operator shall be properly qualified and no person under the age of 21 yrs shall be incharged of any hoisting machine including any scaffolding winch or give signals to operator.

c) In case of every hoisting machine and or every chain ,ring , hook, shackle swivel and pull block used in hoisting or lowering as means of suspension safe working load shall be ascertained by adequate means. Every hoisting machine and all gear referred to above shall have the safe working load plainly marked there on. In case of a hoisting machine having a variable safe working load,each safe working load at the condition under which it is applicable shall be clearly indicated. No part of any machine or gear referred to above in this paragraph shall be loaded be yond the safe working load except for the purpose of testing.

d) In case of department machine ,safe working load shall be notified by the Engineer-in-charge. As regards contractor's machine the contractor shall notify safe working load of each machine to the Engineer-in-charge when ever he brings it to site of work and get it verified by the Engineer-in-charge.

11. Motors , gearing , transmission electric wiring and other dangerous parts of hoisting appliances shall be provided with efficient safeguards, hoisting appliances shall be provided with such means as will reduce to the minimum risk of accident descent of load . Adequate precaution shall be taken to reduce to the minimum risk of any part of a suspended load becoming accidentally displaced. When workers are employed on electrical installations which are already energised insulating mats, working apparel such as gloves, sleeves and boots as may be necessary shall be provided. Workers shall not wear any rings watches ,carry keys or other materials which are good conductors of electricity.
12. All scaffolds , ladders and other safety devices mentioned or described here in shall be maintained in a safe condition and no scaffold , ladder or equipment shall be altered or removed while it is use. Adequate washing facilities shall be provided at or near the places of work.
13. These safety provision shall be brought to the notice of all concerned by display on a notice board at a prominent place at the workspot persons responsible for ensuring compliance with the safety code shall be named thereon by the contractor.
14. To ensure effective enforcement of the rules and regulations relating to safety precaution , arrangement made by the contractor shall be open to inspection by the Engineer-in-charge or his representation and the inspecting officers as defined in the contractor's Labour Regulations.
15. Notwithstanding to the above conditions 1 to 14, the contractor is not exempted from the operation of any other Act or Rule in force.

## **B. GENERAL SAFETY PRECAUTIONS TO BE FOLLOWED AT WORK SITES DURING EXECUTION**

The following safety measures should be strictly adhered to during execution of works at sites.

1. Providing the working platform with toe-board and handrail for continuous working at heights.
2. Providing safety belt and lifeline at all times for men working at heights.
3. Providing dust or fume respirator in places where dust and fume concentration exists
4. Providing goggles and welding screens.
5. Providing acid and alkali proof rubber gloves for handling acids, alkali and chemicals, which are corrosive.
6. Providing rubber gloves for working on electrical works.
7. Ensuring proper lashing of the components while being transported in vehicles.
8. The vehicles must have side supports or have body to support the materials conveyed.
9. The materials should not be allowed to extend or overflow the sides of vehicles.
10. Materials should not be allowed to overhang from the rear edge of the body of the vehicle.
11. Driver of the vehicle must possess license.
12. Vehicle must not be overloaded prescribed limits.
13. Red flags and lights for parts projecting from the body of the vehicle must be provided.
14. The speed restrictions within the factory must be strictly adhered to.
15. The gas cylinders must always be handled on trolleys or kept tied down not in use. They should never be rolled as Roller for conveying.
16. Cylinders should not be used without regulators.
17. All excavations may be barricaded and red belts/ lamps must be provided .
18. All electrical connections must be properly earthed.
19. No work should be taken up for execution inside shop floor, without obtaining necessary work permit.
20. Providing helmet for high level work.
21. The contractor should maintain a register regarding the driver license particulars.
22. All Personnel Protective Equipments (PPE) conform to standard specification as per the details given in the code of conduct.
  - (i) Safety helmets confirming to IS-2925: 1984
  - (ii) Safety Belts confirming to IS-3521: 1983
  - (iii) Safety Shoes confirming to IS-1989: 1978
  - (iv) Eye and face protection devices confirming to IS – 8520:1977 & IS – 8940:1978
  - (v) Hand and body protective devices confirming to: IS – 2573: 1975  
IS – 6994: 1973  
IS – 8807: 1978  
IS – 8519: 1977

Contractor including the subcontractors, agents and labours engaged on work are required to scrupulously adhere to the safety regulations, safety precautions and measures. Any violation thereof will invite punitive action being taken against them. Also contractors with frequent violations of safety regulations will not be entrusted with further work in this organization.

### **General:**

All tools, tackles, lifting appliances, material handling equipment, scaffolds, cradles, safety nets, ladders, equipment etc., used by the contractor shall be of safe design and construction. These shall be tested and certificate of fitness obtained, before putting them to use and from time to time as instructed by authorized BHEL official who shall have the right to ban the use of any item.

### **C. SAFETY PRECAUTION TO BE OBSERVED WHILE TRANSPORTING MATERIALS**

#### **I. Vehicle**

1. Vehicle carrying materials should have proper registration documents and must be produced on demand by our Security staff.
2. The light on right side i.e. over the driver's cabin shall be in working condition
3. Both the head light as well as park lamps must be in working condition.

#### **II. Movement of Vehicle**

1. The vehicle should not travel at more than 20KMPH in our premises.
2. The driver of the vehicle must possess heavy duty licence and produce on demand by the Security Staff.
3. Vehicles carrying inflammable liquids in the tanks containers should have grounding chain or the tank container should be coated with insulating materials to avoid static electricity.
4. In road junction , speed breaker and Railway crossing the speed should be lowered and vehicles should proceed cautiously.
5. The driving should be ' keep to the left ' at all places.
6. The vehicles should not parked on the road which could obstruct the vehicular traffic.
7. No person other than driver should be allowed to sit or stand on the prime mover or trailer.
8. The vehicle should pass only through the approved routes. Short cuts should be forbidden.
9. There must be a safe distance behind another moving truck.
10. The driver should avoid making quick starts, jerk stop or quick turns at excessive speed .

### III Shipping

1. Strong side supports should be provided on both sides of the trailer. The side supports should be fixed in such a way that it cannot be removed even temporarily.
2. Adequate packing must be given for easy slinging operations. The packing materials should be good enough to withstand the load.
3. The stacking of loads on the truck should be evenly placed. The load should not be heaped together or dumped over the chassis.
4. The load on the truck should not be beyond its standard capacity. The carrying capacity must be clearly marked on the trailers also.
5. The loaded materials should be fastened tightly with "WIRE ROPE". Manila rope or coir rope should not at all be used. There must be side packing such as gunny or rubber tyre between the sharp edges of the job and wire rope in order to avoid cut in the wire rope.
6. There must be minimum two fastening and it should be more in case of lengthier loads.
7. The wire rope should be in sound condition i.e there should not be links, knots or bristles etc.
8. The wire rope ends should be clamped with 'U' clamps.
9. The loose pieces should be bundled before loading on the truck.
10. There must be red flags or red lamps for the lengthly loads which extend beyond chassis.
11. The materials should not be stacked too high to avoid hitting against live electric lines.
12. The load should not be overhanging more than 0.9 metres from the end of body.
13. While transporting the scraps, there must be wire net cover to prevent falling of scrap.

### IV General

1. The vehicles should not be moved directly inside the production building in case the materials are to be unloaded there. But the vehicles should be parked outside the building and the driver should ascertain the passage as well as the unloading points, with the help of the shop officials. This will avoid the congestion or blocking of traffic in the gangway.



# MEGA DRIVES PRIVATE LIMITED

Works: W-365, T.T.C Industrial Area, Thane-Belapur Road, Rabale, Thane-400 701, Maharashtra  
• Phone: 022-2769 0257, 2769 2367 • Fax: 022-2769 2367 • Email: megadrive@vsnl.net

25113

MD/QTN/07-0420

20.04.2007

**Bharat Heavy Electricals Ltd.**  
**Ranipet**

Attn: Mr. N.Kangeyan  
Dy. Manager/MTD & TE

Sir,

Sub: Budgetary offer for EOT Cranes  
Ref: Email dt. 11 Apr 2007

We are pleased to offer our budgetary prices for 20T and 100T EOT Cranes as stated further in detail.

### Technical Specifications Of Crane

- |                                |   |  |
|--------------------------------|---|--|
| Ref                            | : | M/s. BHEL Ranipet  |
| 1. Location                    | : | Indoor   |
| 2. Capacity T                  | : | 20 T/5T  |
| 3. Duty                        | : | Class-II – IS:3177& 807                                    |
| 4. Span                        | : | 28.5 M.  |
| 5. Control                     | : | From Cabin   |
| 6. Speeds:                     |   |  |
| AH M/Min                       | : | 5  |
| MH M/Min                       | : | 3  |
| CT M/Min                       | : | 30   |
| LT M/Min                       | : | 50   |
| 7. Height of lift              | : | 8.1 M  |
| 8. Motors                      | : | Motors are slip ring, S4 duty, 40% CDF<br>150 starts /hour |
| 9. Brakes                      | : | Electro Hydraulic Thruster Brake.                          |
| 10. Wt. of Crane               | : | 39Tones  |
| 11. L.T Wheel load             | : | 21 T on 4 wheels   |
| 12. Recommended Size L.T. Rail | : | 90 lbs/yard F.B.Rail                                       |

**Selling Price – 45,00,000/- (Forty Five Lakhs only)**

1

for 100 T crane Specs.  
(PTO)

FINANCE

### Technical Specifications Of Crane

Ref	:	M/s. BHEL Ranipet
1. Location	:	Indoor
2. Capacity T	:	100 T/5T
3. Duty	:	Class-II – IS:3177& 807
4. Span	:	28.5 M.
5. Control	:	From Cabin
6. Speeds :		
AH M/Min	:	5
MH M/Min	:	3
CT M/Min	:	30
LT M/Min	:	50
7. Motors	:	Motors are slipring, S4 duty, 40% CDF 150 starts /hour
8. Brakes	:	Electro Hydraulic Thruster Brake.
9. Wt. of Crane	:	86Tones
10. L.T Wheel load	:	40 T on 8 wheels
11. Recommended,Size L.T. Rail	:	CR100

**Selling Price – 1,00,00,000/- (One Crore Two Lakhs only)**



- Vibrating screens
- Pan feeders
- Gyratory and jaw crushers
- Mold oscillators
- Compressors

plus other equipment that is subjected to dynamic loadings as a consequence of normal operations. Equipment that is subject to rotating or vibratory loading is susceptible to wear and possible failure if vibration levels are excessive. For some installations, it may be necessary to consider both equipment structure interaction and the effects of soil structure interaction on the supporting structure. This would be the case for equipment installations in very stiff buildings.

Equipment specifications should give the desired relationship between the lowest natural frequency of the equipment and the operating frequency.

### 7.7 Wind Loads (3.8)

Most jurisdictions in the U.S. base their building code on one of the model building codes. These codes, in turn, base their wind load provisions on ASCE 7 (Ref. 9), subject to the specific limitations and requirements of the local code. For structures located in Canada, compliance should be with the National Building Code of Canada (Ref. 10).

For flexible buildings or structures, a dynamic analysis of wind loads may be appropriate or even required by code.

For structures associated with a high cost of failure or a high cost of overdesign, it may be a good investment to perform model tests in a wind tunnel in order to more accurately estimate the static and dynamic wind behavior of the structure.

### 7.8 Seismic Forces (3.9)

In determining whether seismic design is required for a structure, one should not assume that significant earthquakes occur only in the western United States. Although earthquakes are less frequent in the east, they may still be quite severe and should be accounted for in the design.

It is important for the design engineer to understand that real earthquakes are a dynamic displacement loading and not just the static force loading assumed by simplified building code calculations. These assumed forces are often greatly reduced from reality and rely on structural ductility well beyond the

Fig. 7.2—Hydraulic Crane Bumper.  
Runway End Stop Example

Bridge weight, $W_B = 200$ kips
Bridge full load rated speed, $V_B = 6$ ft. per second
Trolley weight, $W_T = 40$ kips
Impact weight per side (load free to swing), $W_E = 0.5 W_B + 0.9^{\dagger} W_T = 136$ kips
<sup>†</sup> Confirm 0.9 with crane manufacturer
Allowable deceleration (per AISE TR 6): $A_{50\%} \leq 16$ ft/sec <sup>2</sup> @ 50% speed
For deceleration at 50% of full load rated speed:  Stroke must be at least $((V_{50\%})^2(12''))/(2 * A_{50\%})$  Stroke must be at least $= \frac{3^2 \times 12}{2 \times 6} = 3.38$ in.  Deceleration force must not exceed $(W_E/g) * A_{50\%}$  Deceleration force must not exceed $\frac{136}{32.2} \times 16 = 67.6$ kips
Note: The stroke of 3.38 in. is for a 100% efficient bumper and must be adjusted for the actual bumper efficiency. Bumper efficiency varies with the type of bumper and individual bumper design. Typical hydraulic bumper efficiency is 80%, sometimes more. Coil spring bumper efficiency is 50%. For example, if a hydraulic bumper is 80% efficient, then the stroke must be increased to $\frac{3.38}{0.8} = 4.23$ in.
For energy absorption at 100% of full load rated speed: Kinetic energy $K_E$ to be absorbed $= \frac{W_E V_B^2}{2g} = \frac{136 \times 6^2 \times 1000}{2 \times 32.2} = 76,025$ lb-ft
The end force $F_e$ is inversely proportional to the stroke, $S_B$ , and to the efficiency, $E_B$ , of the bumper, $F_e = \frac{K_E}{S_B E_B}$
For example, a bumper with maximum stroke of 10 in. and 80% efficiency would generate a force of: $\frac{76,025 \times 12}{10 \times 0.8} = 114,038$ lb
If the maximum allowable force on the runway stop is say, 100,000 lb, then the bumper supplier must find a combination of energy absorption, stroke and efficiency that will satisfy this criterion. The bumper must also satisfy the requirement for deceleration at 50% of full load rated speed.
For end force not to exceed 100,000 lb, the bumper stroke would be adjusted as follows: $S_B = \frac{76,025 \times 12}{100,000 \times 0.8} = 11.4$ in.
Therefore, for this example, an acceptable hydraulic bumper at 80% efficiency will have the following characteristics: minimum stroke length = 11.4 in. maximum end force at 100% speed = 100 kips

The energy absorption device (e.g., hydraulic or spring) shall be designed/selected to satisfy the following criteria:

- (1) The deceleration rate for the bridge shall not exceed 16 ft. per second squared at 50% of the full load rated speed or at 50% of the maximum attainable speed, if known.
- (2) The device shall be capable of absorbing the energy at 100% of the full load rated speed
- (3) The maximum force generated by the device shall be less than maximum allowable force on the runway stop.

The building, the end stops and their connections shall be designed to withstand the force generated at 100% of the full load rated speed. The recommended increase in the allowable stresses for this condition is 50%.

For computing bridge bumper energy absorption requirements, the trolley must be placed in the end approach producing the maximum end reaction from both bridge and trolley (See Fig. 7.1). This end reaction shall be used as the maximum weight portion of the crane that can act on each bridge bumper. The energy-absorbing capacity of the bumper is based on "power off" and does not normally include the lifted load if it is free to swing.

For new construction, careful attention to reductions in bumper end force can produce cost savings in runway girders, end stop and support structure designs.

The bumper supplier should be required to supply certification of the performance of the proposed bumper. The height of the bumper above the top of rail must be coordinated with or determined by the crane manufacturer.

Fig. 7.2 shows basic calculations for hydraulic and spring bumpers.

### 7.6 Vibration (3.7.1)

Rotating and vibrating equipment should be designed to minimize excessive vibration levels. Examples are:

- Motors
- Turbines
- Fans/blowers

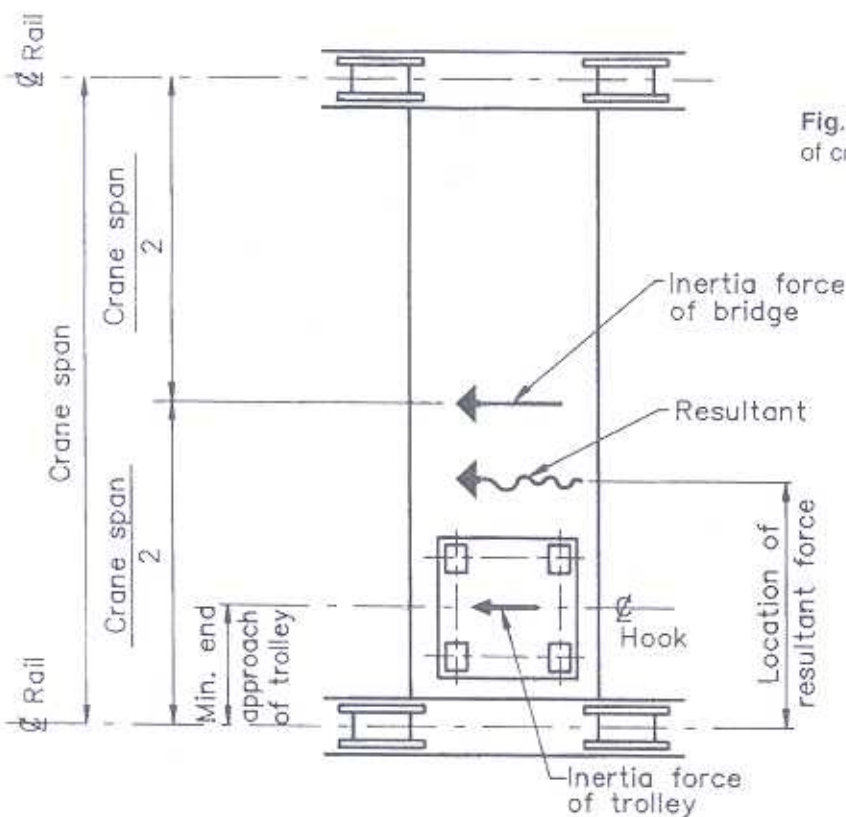
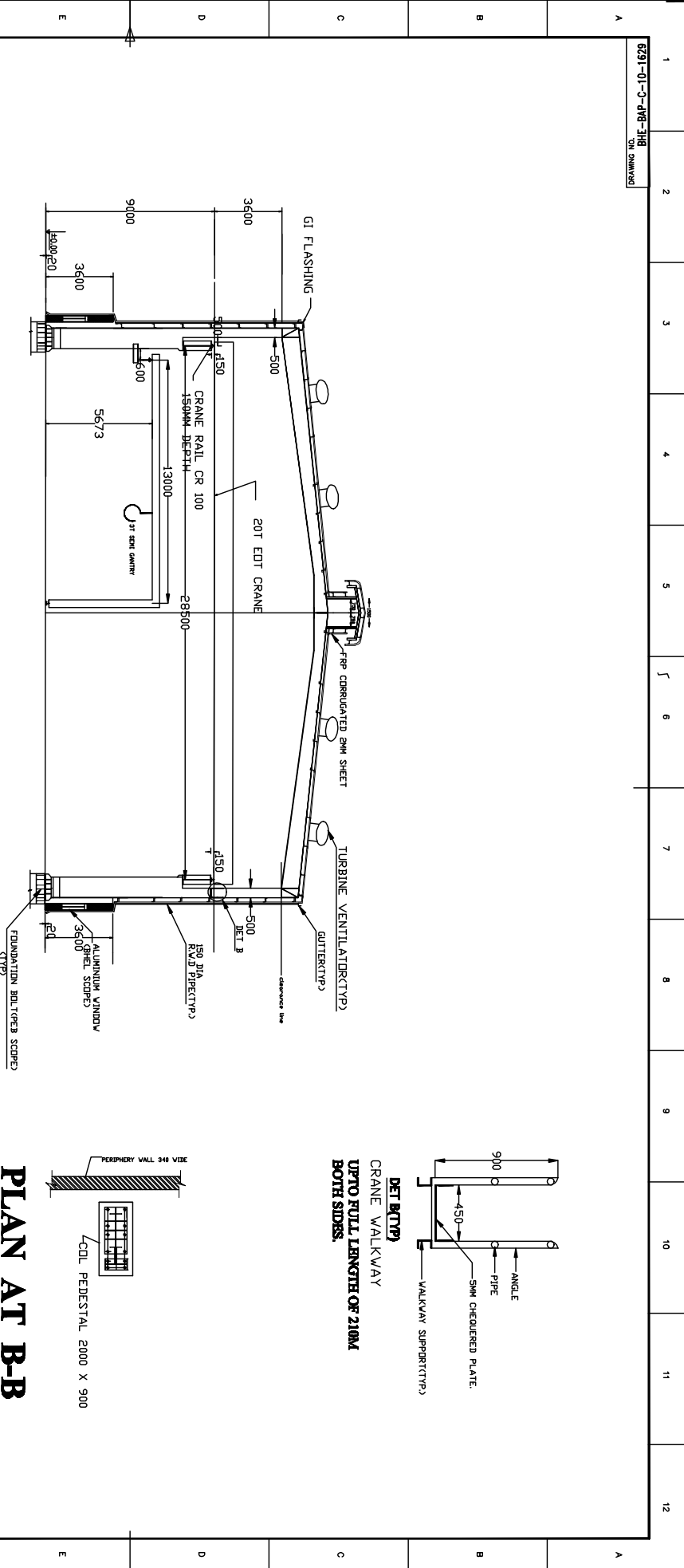

Fig. 7.1—Location of total inertia force of crane.





# SECTION ON AA

- NOTES:-**
1. ALL DIMENSIONS ARE IN MILLIMETRE
  2. ALL LEVELS ARE IN METRE
  3. ONLY WRITTEN DIMENSIONS SHALL BE FOLLOWED
  4. FOR FOUNDATION DETAILS REFER BHE-BAP-C-20-1049
  5. FOR PLAN OF SHED REFER DRG. NO BHE-BAP-C-10-1629 SHEET 1 OF 2

**SCHEDULE OF JOINTERS:-**  
RS-ROLLING SHOTTER  
(5000X5000)

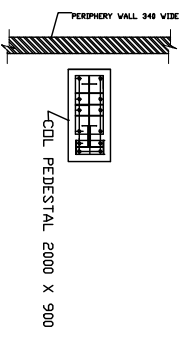
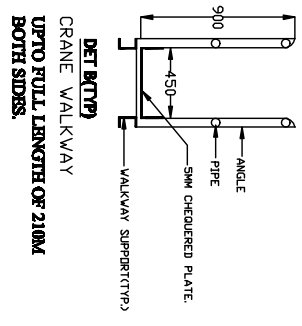

# PLAN AT B-B

TYPE OF PRODUCT OR NAME OF CUSTOMER/PROJECT		FACTORY	
BHARAT HEAVY ELECTRICALS LTD.		BHARAT HEAVY ELECTRICALS LTD.	
DATE	SCALE	NO.	DATE
01/11/20	N.T.S	01	01/11/20
DESIGN	SCALE	NO.	DATE
U 01	N.T.S	01	01/11/20
BHEC OF NEW ROLLING BAY		BHEC OF NEW ROLLING BAY	
SHEET 2 OF 2		SHEET 2 OF 2	
DRAWING NO.		DRAWING NO.	
BHE-BAP-C-10-1627 00		BHE-BAP-C-10-1627 00	
SHEET 2 OF 2		SHEET 2 OF 2	



EXACT LOCATION ON THE ROOF LEG WILL BE GIVEN LATER

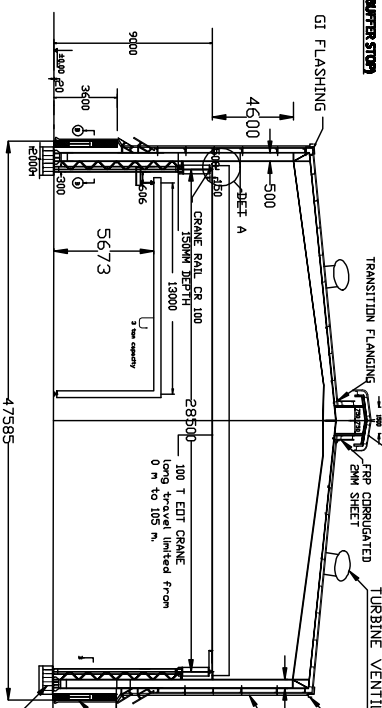
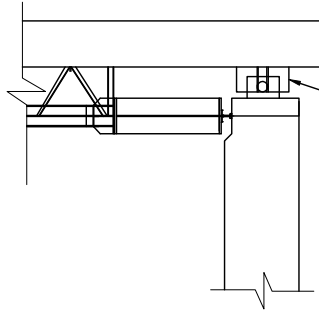

**SECTION ON BB**

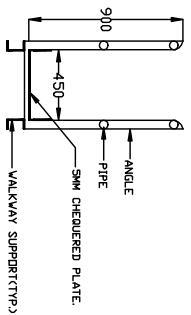

**DETAIL B(TYP)  
CRANE WALKWAY  
UPTO FULL LENGTH OF 210M  
BOTH SIDES.**

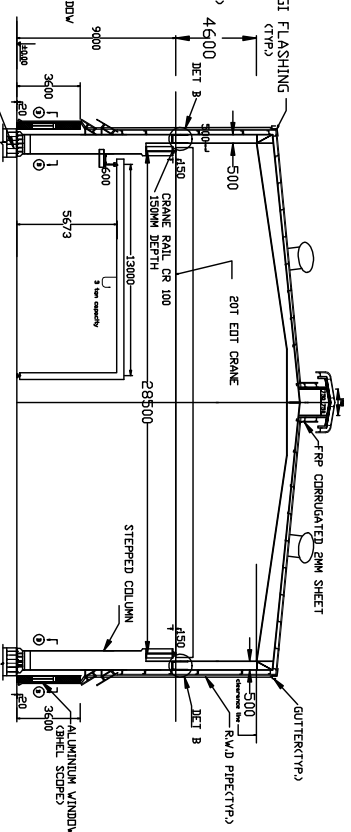

**SECTION ON AA**

- NOTES:-**
1. ALL DIMENSIONS ARE IN MILLIMETRE
  2. ALL LEVELS ARE IN METRE
  3. ONLY WRITTEN DIMENSIONS SHALL BE FOLLOWED
  4. FOR FOUNDATION DETAILS REFER BHE-BAP-C-20-1049
  5. FOR PLAN OF SHED REFER DRG. NO BHE-BAP-C-10-1629 SHEET 1 OF 2

**PLAN AT B-B**

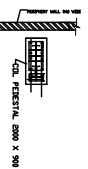

**SCHEDULE OF JOINTERS:-  
RS-ROLLING SHUTTER  
(5000X5000)**

TYPE OF PRODUCT OR NAME OF CUSTOMER/PROJECT		<b>FACTORY</b>	
DATE	APPROVED	DATE	APPROVED
CAUTION: The information on this drawing is the property of BHARAT HEAVY ELECTRICALS LTD. It must not be used for any other purpose without the written consent of the company.		SCALE: N.T.S.	
DESIGN	SCALE	DATE	SCALE
CHKD	SCALE	DATE	SCALE
REV	SCALE	DATE	SCALE
SEC. OF NEW FABRICATION BAY		SEC. OF NEW FABRICATION BAY	
U 01	U 01	U 01	U 01
DRAWING NO. BHE-BAP-C-10-1629 00		DRAWING NO. BHE-BAP-C-10-1629 00	
SHEET 2 OF 2		SHEET 2 OF 2	

