

THE INFMN ON THIS DOCUMENT IS THE PROPERTY OF BHEL.
 IT MUST NOT BE USED DIRECTLY OR INDIRECTLY
 IN ANY WAY DETRIMENTAL TO THE INTEREST OF BHEL

REV	DATE	ALTERED :
		CHD./APPD. :

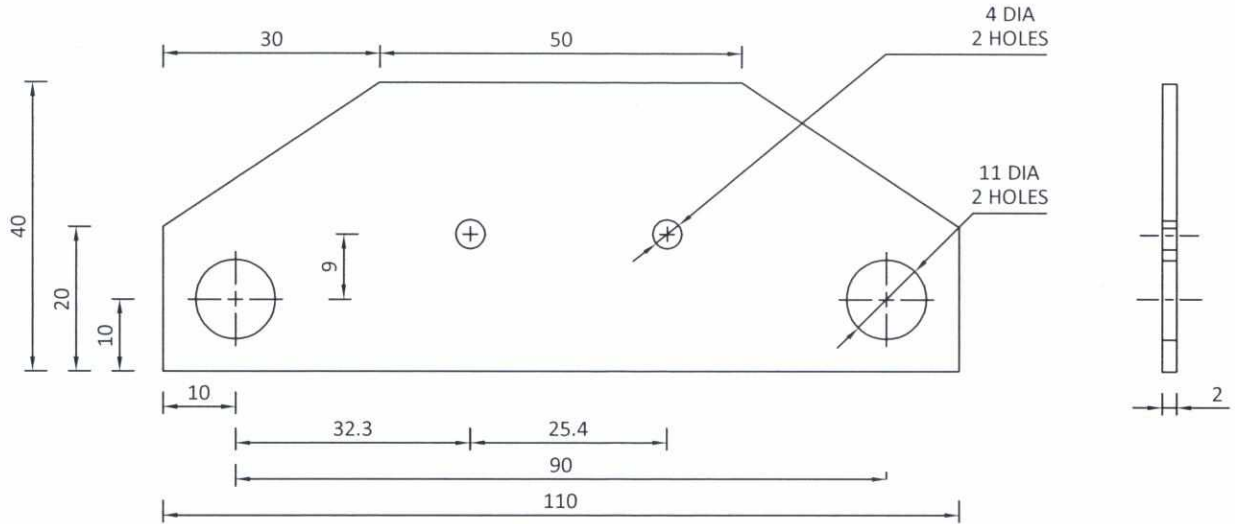

DETAIL	
1.	MATERIAL CODE : 96424126
2.	QUANTITY / FEEDER : 2Nos.
3.	MATERIAL : BLACK BAKELITE - TYPE XP.
4.	FEEDER SIZE : 36" / 24"
5.	STOCK REFERANCE PART NO. W8264-1

THIS DRG SUPERSEDS EARLIER SPEC. NO. GF-193 REV.01
 AND DRG. NO 4-65-736-00734 / 01

TYPE OF PRODUCT OR NAME OF CUSTOMER / PROJECT: **GRAVIMETRIC COAL FEEDER CONTROLS**

	Bharat Heavy Electricals Ltd UNIT : HIGH PRESSURE BOILER PLANT TIRUCHIRAPPALLI - 620014	DRN	NAME S.Kalaiselvi	SIGNATURE <i>S. Kalaiselvi</i>	DATE 11-04-18	NO. OF VAR
		CHD	K.Veeramani	<i>K. Veeramani</i>	30-07-18	—
		APPD	T.Kanagaraj	<i>T. Kanagaraj</i>	30-07-18	—

DEPT. : C&I		ALL DIMENSIONS ARE IN MM	SCALE NTS	WEIGHT (Kg) —	REF TO ASSY / OLD DWG —	ITEM NO —	No OF ITEMS —
-------------	---	--------------------------	--------------	------------------	----------------------------	--------------	------------------

TITLE: TECHNICAL SPECIFICATION FOR PADDLE SWITCH SUPPORT BARRIER	CARD CODE U 01	DRAWING NO : 4-95-488-05893	REV 00
--	-------------------	---------------------------------------	------------------

THE INFMN ON THIS DOCUMENT IS THE PROPERTY OF BHEL.
IT MUST NOT BE USED DIRECTLY OR INDIRECTLY
IN ANY WAY DETRIMENTAL TO THE INTEREST OF BHEL.

REV	DATE	ALTERED :
		CHD./APPD. :

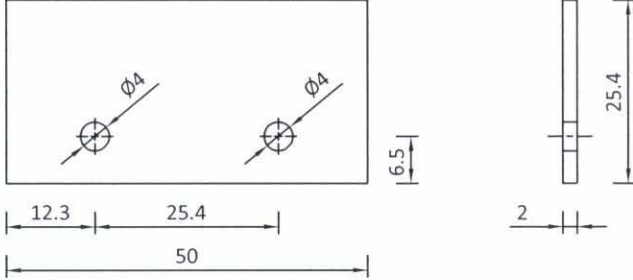

DETAIL	
1.	MATERIAL CODE : 96424127
2.	MATERIAL TYPE : XP - BLACK BAKELITE
3.	QUANTITY / FEEDER : 7 Nos.
4.	STOCK REFERENCE PART NO : W171-1.

THIS DRG SUPERSEDS EARLIER SPEC. NO. GF-194 REV.01

TYPE OF PRODUCT OR NAME OF CUSTOMER / PROJECT **GRAVIMETRIC COAL FEEDER CONTROLS**

	Bharat Heavy Electricals Ltd UNIT : HIGH PRESSURE BOILER PLANT TIRUCHIRAPPALLI - 620014	DRN	NAME	SIGNATURE	DATE	NO. OF VAR
			S.Kalaiselvi	<i>S.Kalaiselvi</i>	11-04-18	
		CHD	K.Veeramani	<i>K.Veeramani</i>	30-07-18	—
		APPD	T.Kanagaraj	<i>T.Kanagaraj</i>	30-07-18	

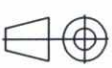
DEPT. : C&I		ALL DIMENSIONS ARE IN MM	SCALE NTS	WEIGHT (Kg)	REF TO ASSY / OLD DWG	ITEM NO	No OF ITEMS
CODE : 392				—	—	—	—

TITLE:	CARD CODE	DRAWING NO :	REV
ELECTRICAL BARRIER FOR SWITCH GRAVIMETRIC FEEDER	U 01	4-95-488-05894	00
		Sheet 01 of 01	