

59	TEMPERATURE SWITCH	INDFOS (INDIA) LIMITED	MR.L.C.VENKATRANGAN/MR.B.KANNAN New No.17, II Floor, Adwave Towers, Dr.Sevalia Shivaji Salai, T.Nagar Chennai Phone- +91 44 24353407 Pincode : 600017 Email : delhi@indfos.com
60	TEMPERATURE SWITCH	SWITZER PROCESS INSTRUMENTS PVT. LTD.	Mr. V S Jayaprakash, 128, SIDCO North Phase, Ambattur Estates CHENNAI Phone- 044-26252017/2018 Pincode : 600050 Email : sales@switzerprocess.co.in
61	DIFFERENTIAL PRESSURE SWITCH	SOR INC.	LARRY DEGARMO/Avdshesh Chandra, 14685 W. 105TH STREET LENEXA Phone- 09810905139, Pincode : 66215 Email : Ldegarmo@sorinc.com, avdshesh@sherman-india.com,
62	JUNCTION BOX	K.S.INSTRUMENTS PVT.LTD.	S Raghavan No. 72, 3rd Main, 1st Stage Industrial Suburb, Yeshwanthpur Bangalore Phone- 9880385770 Pincode : 560022 Email : sales1@ksinstruments.net
63	JUNCTION BOX	SUCHITRA INDUSTRIES	NO-2,OPP-27 AECS LAYOUT 2ND STG REJAMAHALVILAS EXTN 2ND STG BANGALORE Phone- Pincode : Email : suchitra.industriesblr@gmail.com
64	JUNCTION BOX	Shrenik & Company,	Mr. Mitesh Shah/Mr. Pulin Shah 39 A/3 ,Panchratna Industrial Estate, Sarkhej-Bavla Road Ahmedabad Phone- 9825024921 Pincode : 382213 Email : sales@pustron.com, pulin@sumip.com
65	JUNCTION BOX	FLEXPRO ELECTRICALS PVT. LTD.	Mr. Dineshbhai Zaveri C-1/ 27&37, GIDC, Kabilpore, Navsari Phone- 02637-265140,265003 Pincode : 396424 Email : flexpro@flexproltd.com
66	JUNCTION BOX	AJMERA INDUSTRIAL & ENGINEERING WORKS	JIGNESH MAHENDRA AJMERA DENA BANK BLDG.,SHREE NAGESH INDL. ESTATE,STATION ROAD, MUMBAI Phone- 022 67973578 Pincode : 400 088 Email : ajmera@ajmera.net, jmajmera@yahoo.com
67	INSTRUMENTS TUBE FITTINGS	VIKAS INDUSTRIAL PRODUCTS	S.R.SINGH/NAVEEN SINGH B - 2, SECTOR - 6, NOIDA Phone- +91-9810122070 Pincode : 201301 Email : naveensingh@vsnl.com
68	INSTRUMENTS TUBE FITTINGS	Fluid Controls Pvt. Ltd.	Sophie Y. Moochhala/Mayur Rajput J.V.PATEL, I.T.I CMPD, B.MADHUKAR MARG, ELPHINSTONE ROADSTN.(WR), MUMBAI Phone- (022) 43338000 Pincode : 400013 Email : sales@fluidcontrols.com
69	INSTRUMENTS TUBE FITTINGS	AURA INCORPORATED	NIRAJ SHARAN/SUJIT KUMAR W-167A, GREATER KAILASH-II NEW DELHI Phone- 9810182430 Pincode : 110048 Email : niraj@aurainc.com
70	INSTRUMENTS TUBE FITTINGS	PRECISION ENGINEERING INDUSTRIES	K. SITARAM/ K. SRINIVAS 7,SIDHAPURA INDUSTRIAL ESTATE S.V. ROAD,GOREGAON(W) MUMBAI Phone- 022 42631700 Pincode : 400 062 Email : peiks@vsnl.com
71	LEVEL SWITCH-CAPACITANCE TYPE	SIGMA INSTRUMENTS CO.	Gopal Kannan/R Gopinath 201, ANANDRAJ INDUSTRIAL ESTATE, OFF.LBS MARG, SONAPUR LANE, BHANDUP (W) MUMBAI Phone- +919821038162 Pincode : 400078 Email : sales@sigmainstruments.co.in

## 46442/2020/PS-PEM-MAX

72	LEVEL SWITCH-CAPACITANCE TYPE	V. AUTOMAT & INSTRUMENTS (P) LTD.	Mr. R. K. BASSI/Mr. PRAVEEN KUMAR F-61, OKHLA INDL.AREA, PH-1 NEW DELHI Phone- 9810005826 Pincode : 110 020 Email : sales@vautomat.com
73	LEVEL SWITCH-CAPACITANCE TYPE	SCIENTIFIC DEVICES (BOMBAY) PVT LTD,	Office no. 53, Shree Manoshi Complex, Plot No. 5 & 6, Sec-3, Ghansoli (East), Navi Mumbai, Phone- 9892230623, Pincode : 400 701, Email : sdbpl@vsnl.com
74	LEVEL SWITCH-CAPACITANCE TYPE	LEVCON INSTRUMENTS PVT. LTD.	Mr Shayak Gupta/Badal Jana Rajkamal', 7th floor, 13, Camac Street KOLKATA Phone- 0 33 2283 2766 Pincode : 700017 Email : b_jana@levcongroup.com
75	LEVEL SWITCH-CAPACITANCE TYPE	Flow Star Engineering Pvt. Ltd.,	MR. KHALID AKHTAR/MR. TAPAN KUMAR JANA Plot No- 7 F/2, Northern India Industrial 20/3, Mathura Road FARIDABAD Phone- 9818176380 Pincode : 121005 Email : khalid@flowstar.co.in
76	LEVEL SWITCH-CAPACITANCE TYPE	Pune Techtrol Pvt. Ltd.	N.P.Khatan/Sudhakar Badiger S-18, MIDC Bhosari, Pune Phone- 9850560042 Pincode : 411 026 Email : ho@punetechtrol.com
77	LEVEL SWITCH-CAPACITANCE TYPE	Baumer Technologies India Pvt. Ltd.	Mr. Shyam Warilani/Mr. V Suresh Babu 36, DAMJI SHAMJI INDUSTRIAL COMPLEX, OFF.-MAHAKALI CAVES ROAD, ANDHERI(E) MUMBAI Phone- +91 99589 25151 Pincode : 400093 Email : sales.in@baumer.com
78	LEVEL SWITCH-CONDUTIVITY TYPE	Sapcon Instrument Pvt Ltd.	131, PALSHIKAR COLONY Contact Person- Mr. Ashwin (9826080207) INDORE Phone- +91-731- 4085751, Pincode : 452004 Email : sales@sapconinstruments.com
79	LEVEL SWITCH-CONDUTIVITY TYPE	LEVCON INSTRUMENTS PVT. LTD.	Mr Shayak Gupta/Badal Jana Rajkamal', 7th floor, 13, Camac Street KOLKATA Phone- 0 33 2283 2766 Pincode : 700017 Email : b_jana@levcongroup.com
80	LEVEL SWITCH-CONDUTIVITY TYPE	BLISS ANAND PVT. LTD.	Mr. Vikas Anand/ Mr.RGRajan 92B & 93 B , IMT MANESAR Gurgaon Phone- 0124-4366000 TO 9 Pincode : 122001 Email : sales@blissanand.com
81	LEVEL SWITCH-CONDUTIVITY TYPE	V. AUTOMAT & INSTRUMENTS (P) LTD.	Mr. R. K. BASSI/Mr. PRAVEEN KUMAR F-61, OKHLA INDL.AREA, PH-1 NEW DELHI Phone- 9810005826 Pincode : 110 020 Email : sales@vautomat.com
82	LEVEL SWITCH-CONDUTIVITY TYPE	HI-TECH SYSTEMS & SERVICES LTD.	Mr. Vikash Agrawal/Mr. Tarun Debnath 119, PARK STREET , KOLKATA Phone- 033-22290045 Pincode : 700016 Email : sandeep@hitech.in
83	LEVEL SWITCH-CONDUTIVITY TYPE	RAMAN INSTRUMENTS PVT.LTD.	Mr. N R Shenoy/Mr G B Vjih 8, First Floor.Plot : 160A Bait-Ush-Sharaf, 29th Road,Bandra(W) MUMBAI Phone- 09892331381 Pincode : 400050 Email : ramanbpl@vsnl.com
84	LEVEL SWITCH-CONDUTIVITY TYPE	SIGMA INSTRUMENTS CO.	Gopal Kannan/R Gopinath 201, ANANDRAJ INDUSTRIAL ESTATE, OFF.LBS MARG, SONAPUR LANE, BHANDUP (W) MUMBAI Phone- +919821038162 Pincode : 400078 Email : sales@sigmainstruments.co.in
85	LEVEL SWITCH-CONDUTIVITY TYPE	SOR INC.	LARRY DEGARMO/Avdhesh Chandra, 14685 W. 105TH STREET LENEXA Phone- 09810905139, Pincode : 66215 Email : Ldegarmo@sorinc.com, avdhesh@sherman-india.com,

## 46442/2020/PS-PEM-MAX

86	LEVEL SWITCH-FLOAT TYPE	Pune Techtrol Pvt. Ltd.	N.P.Khatan/Sudhakar Badiger S-18, MIDC Bhosari, Pune Phone- 9850560042 Pincode : 411 026 Email : ho@punetechtrol.com
87	LEVEL SWITCH-FLOAT TYPE	D.K. INSTRUMENTS PVT.LTD.	N.SIKDAR/ SUMIT SIKDAR 76/2,SELIMPUR RD DHAKURIA Kolkata Phone- 033-2415-1310. Pincode : 700031 Email : dkinst@vsnl.net
88	LEVEL SWITCH-FLOAT TYPE	V. AUTOMAT & INSTRUMENTS (P) LTD.	Mr. R. K. BASSI/Mr. PRAVEEN KUMAR F-61, OKHLA INDL.AREA, PH-1 NEW DELHI Phone- 9810005826 Pincode : 110 020 Email : sales@vautomat.com
89	LEVEL SWITCH-FLOAT TYPE	SCIENTIFIC DEVICES (BOMBAY) PVT LTD,	Office no. 53, Shree Manoshi Complex, Plot No. 5 & 6, Sec-3, Ghansoli (East), Navi Mumbai, Phone- 9892230623, Pincode : 400 701, Email : sdbpl@vsnl.com
90	LEVEL SWITCH-FLOAT TYPE	LEVCON INSTRUMENTS PVT. LTD.	Mr Shayak Gupta/Badal Jana Rajkamal', 7th floor, 13, Camac Street KOLKATA Phone- 0 33 2283 2766 Pincode : 700017 Email : b_jana@levcongroup.com
91	LEVEL SWITCH-FLOAT TYPE	GENERAL INSTRUMENTS CONSORTIUM	Mr. Amarendra Kulkarni 194/195, Gopi Tank Road, Off. Pandurang Naik Marg, Mahim Mumbai Phone- 9323195251 Pincode : 400016 Email : amarendra@general-gauges.com
92	LEVEL SWITCH-FLOAT TYPE	SBEM PVT. LTD.	MR.N.K. BEDARKAR/MR. VISHWANATH KARANDIK 39, ELECTRONIC CO.OP. ESTATE, PUNE SATARA ROAD PUNE, Phone- 912041030100 Pincode : 411009 Email : newdelhi@sbem.co.in
93	LEVEL SWITCH-FLOAT TYPE	Baumer Technologies India Pvt. Ltd.	Mr. Shyam Warilani/Mr. V Suresh Babu 36, DAMJI SHAMJI INDUSTRIAL COMPLEX, OFF.-MAHAKALI CAVES ROAD, ANDHERI(E) MUMBAI Phone- +91 99589 25151 Pincode : 400093 Email : sales.in@baumer.com
94	LEVEL SWITCH-FLOAT TYPE	SIGMA INSTRUMENTS CO.	Gopal Kannan/R Gopinath 201, ANANDRAJ INDUSTRIAL ESTATE, OFF.LBS MARG, SONAPUR LANE, BHANDUP (W) MUMBAI Phone- +919821038162 Pincode : 400078 Email : sales@sigmainstruments.co.in
95	LEVEL SWITCH-FLOAT TYPE	SOR INC.	LARRY DEGARMO/Avdshesh Chandra, 14685 W. 105TH STREET LENEXA Phone- 09810905139, Pincode : 66215 Email : Ldegarmo@sorinc.com, avdshesh@sherman-india.com,
96	INSTRUMENTS PIPE FITTINGS	VIKAS INDUSTRIAL PRODUCTS	S.R.SINGH/NAVEEN SINGH B - 2, SECTOR - 6, NOIDA Phone- +91-9810122070 Pincode : 201301 Email : naveensingh@vsnl.com
97	INSTRUMENTS PIPE FITTINGS	Fluid Controls Pvt. Ltd.	Sophie Y. Moochhala/Mayur Rajput J.V.PATEL, I.T.I CMPD, B.MADHUKAR MARG, ELPHINSTONE ROADSTN.(WR), MUMBAI Phone- (022) 43338000 Pincode : 400013 Email : sales@fluidcontrols.com
98	INSTRUMENTS PIPE FITTINGS	PRECISION ENGINEERING INDUSTRIES	K. SITARAM/ K. SRINIVAS 7,SIDHAPURA INDUSTRIAL ESTATE S.V. ROAD,GOREGAON(W) MUMBAI Phone- 022 42631700 Pincode : 400 062 Email : peiks@vsnl.com
99	INSTRUMENTS PIPE FITTINGS	AURA INCORPORATED	NIRAJ SHARAN/SUJIT KUMAR W-167A, GREATER KAILASH-II NEW DELHI Phone- 9810182430 Pincode : 110048 Email : niraj@aurainc.com

100	INSTRUMENT FITTINGS	Perfect Instrumentation Control (India) Pvt. Ltd.	MD Hussain Shaikh/Shahanawaz Khan Gala No. 168, Loheki Chwal,216/ 218, Maulana Azad Rd. Nagpada Junction Mumbai Phone- 91-9324383121 Pincode : 400008 Email : shahanawaz.khan@perfectinstrumentation.com
101	INSTRUMENT FITTINGS	Arya Crafts & Engineering Pvt. Ltd.	Mr.Sanjay Brahman/Mr.Shyam Vazirani 102, Vora Industrial Estate No.4 Navghar, Vasai Road (E) Dist.Thane, Mumbai Phone- +91-250-2392246 Pincode : 401210 Email : arya@aryaengg.com
102	INSTRUMENT FITTINGS	AURA INCORPORATED	NIRAJ SHARAN/SUJIT KUMAR W-167A, GREATER KAILASH-II NEW DELHI Phone- 9810182430 Pincode : 110048 Email : niraj@aurainc.com
103	INSTRUMENT FITTINGS	PRECISION ENGINEERING INDUSTRIES	K. SITARAM/ K. SRINIVAS 7,SIDHAPURA INDUSTRIAL ESTATE S.V. ROAD,GOREGAON(W) MUMBAI Phone- 022 42631700 Pincode : 400 062 Email : peiks@vsnl.com
104	INSTRUMENT FITTINGS	Comfit & Valve Pvt. Ltd.	Mr. Jeetu Jain/Mr. Vinay Sosa Survey No. 23/1, Part 2, Ahmedabad-Mehsana Highway Laxmipura, Nandasan Phone- 02764-267036/37 Pincode : 382705 Email : marketing@com-fit.com
105	INSTRUMENT FITTINGS	HP VALVES & FITTINGS INDIA PVT. LTD.	S. Harichandran/P.S. Pandi B-11, Mugappair Industrial Estate, CHENNAI Phone- 044 26252537 Pincode : 600037 Email : sales@hpvalvesindia.com
106	INSTRUMENT FITTINGS	FLUIDFIT ENGINEERS PVT. LTD.	Mr. Abbas Bhola Potia Building No. 2, Office No. 3,292, Bellasis Road,Mumbai Central (East) Mumbai Phone- 9920044113 Pincode : 400008 Email : ab@fluidfitengg.com
107	INSTRUMENT FITTINGS	VIKAS INDUSTRIAL PRODUCTS	S.R.SINGH/NAVEEN SINGH B - 2, SECTOR - 6, NOIDA Phone- +91-9810122070 Pincode : 201301 Email : naveensingh@vsnl.com
108	INSTRUMENT FITTINGS	Fluid Controls Pvt. Ltd.	Sophie Y. Moochhala/Mayur Rajput J.V.PATEL, I.T.I CMPD, B.MADHUKAR MARG, ELPHINSTONE ROADSTN.(WR), MUMBAI Phone- (022) 43338000 Pincode : 400013 Email : sales@fluidcontrols.com
109	INSTRUMENT FITTINGS	PANAM ENGINEERS	Mr. Santosh Shukla 203, Jaisingh Business,Parsiwada, Sahar road,Andheri(East), Mumbai, Phone- 9892179529, Pincode : 400099, Email : santosh@panamengineers.com,

**Notes:-**

- 1.)The above Sub-Vendor list is tentative & reference only. However Sub-Vendor List is subject to BHEL/End user approval without any commercial /delivery implication.
- 2.)New Sub-Vendor if proposed by Vendor during contract stage shall subject to BHEL/end user approval without commercial/delivery implication.



## KKS NUMBERING PHILOSOPHY

### KKS NUMBERING PHILOSOPHY

For identifying (tagging) an instrument / equipment in Power plant KKS numbering scheme is used. The purpose is to assign a unique number to every equipment in the power plant. For C&I equipment unique number are to be provided up to the signal level so that a unique number Input / Output exist in DCS for every signal.

Normally KKS number is a 10 digit alpha-numeric code and is typically split into the following:

X	X	X	A	A	Y	Y	B	B	B
---	---	---	---	---	---	---	---	---	---

First three digits indicate the Sub-System. The Code for the major system are given as per **Annexure-1**.

Fourth and Fifth digits are the **Numerical Keys at System Code Level** and used to distinguish between main systems having same Alpha Codes.

Sixth and Seventh digits are the **Equipment / Apparatus / Measuring Circuit Code**. The code of various Equipment / Apparatus / Measuring Circuit is shown in **Annexure-2**

Eight, Nine and tenth digits are the **Numerical Keys at Equipment / Apparatus / Measuring Circuit Code** and used to distinguish between various instruments in the same sub-group. Numerical keys at System / Equipment / Apparatus / Measuring Circuit is shown in **Annexure-3**.

\*\*

KKS TAGS ARE PROVIDED IN THE P&ID FURNISHED BY VENDOR. HOWEVER, IF THE KKS NUMBER OF EQUIPMENT/INSTRUMENTS CHANGES, THE SAME SHALL BE FINALIZED DURING DETAILED ENGINEERING.



## KKS NUMBERING PHILOSOPHY

## ANNEXURE-1

## List of System / Sub-System Codes used in Power Plant:

- 1) Refer the P&ID sheets.

## ANNEXURE-2

## Standard Equipment Codes:

AA	Valves including drives, also hand operated
AB	Seclusions, Lock, Gates, Doors
AC	Heat Exchanger
AE	Turning, Driving, Lifting equipment
AF	Continuous conveyors, Feeders
AG	Generator Units
AH	Heating and Cooling Units
AK	Pressing and Packaging equipment
AM	Mixer, Stirrer
AN	Blower, Air Pumps / Fans, Compressor Units
AP	Pump Units
AT	Purification, Drying, Filter
AV	Combustion Equipment e.g. grates

## Standard Apparatus Codes:

BB	Vessels and Tank
BF	Foundation
BG	Boiler Heating Surfaces
BN	Injector, Ejector
BP	Flow and throughput limitation equipment (Orifice)
BQ	Holder, Carrying Equipment, Support
BR	Piping, Ducts, Chutes, Compensator
BS	Sound Absorber
BU	Insulations, Sheatings

## Standard Measuring Circuits Codes:

CD	Density
CE	Electrical Quantities
CF	Flow, throughput
CG	Distance, Length, Position
CK	Time
CL	Level



## KKS NUMBERING PHILOSOPHY

CM	Humidity
CQ	Analysis (SWAS)
CS	Speed, Velocity, Frequency
CT	Temperature
CY	Vibration, Expansion

## ANNEXURE-3

## Numerical Keys

## A) Numerical Keys at System Code Level

- i) Use 10, 20, 30... To distinguish between main systems having same Alpha Codes. Examples:
  - a) Main Steam (Left) and Main Steam (Right)
  - b) BFP – A/B/C
  - c) ID Fan – A/B, FD Fan A/B, AH – A/B
- ii) For branch off from main system path having code say 10, keep the same alpha code and use 11, 12, 13 etc. Similarly for other branch off from main system path having code say 20, keep the same alpha code and use 21, 22, 23 etc and shall carry on further in the same way.
- iii) If the branch off from main system / sub system path is used for some other system, where different alpha codes can be applied, then in that case the said branch line will be designated by the alpha codes of the system to which it is providing the input.

## B) Numerical keys at Equipment Code level:

There are three numerical keys available for each type of equipment code. Following has been agreed upon considering present practice, better flexibility and ease in sorting.

i) Valves and Dampers --- *Equipment Code – AA*

		<u>N1</u>	<u>N2 N3</u>
Motorised ( <i>on/off duty</i> )	-	0	01 to 50
Motorised ( <i>inching duty</i> )	-	0	51 to 99
Pneumatic (Control)	-	1	01 to 50
Motorised ( <i>thyrestor Control</i> )	-	1	51 to 99
Sol. Operated	-	2	01 to 99
(Open / Close duty (Valves, NRVs, Gate)			
Hydraulic	-	3	01 to 99



## KKS NUMBERING PHILOSOPHY

NRV (Without actuation)	-	4	01 to 99
Manual	-	5	01 to 99
Manual	-	6	01 to 99
Relief & Safety Valves	-	7	01 to 99
Reserve	-	8	01 to 99
Reserve	-	9	01 to 99

ii) **Field Instruments**

Field Transmitters & Analog Signals	-	0	01 to 99
Field Switches & Binary Signals	-	1	00 to 99
PG Test Point	-	4	00 to 99
Gauges	-	5	00 to 99
Automatic Turbine Tester (ATT)-HWR	-	2	00 to 99

(Reserved for protection Signals used by Hardwar)

**Example of Numerical Key Usage:**

In line with the philosophy adopted for Valves / Dampers /instruments etc. pumps and fans in the main systems (having different system code) can be numbered as AP/N100 and as AP/N101, 102, ..... Where system code is same.





**2x250 MW NSPCL BHILAI TPP**  
**(FGD SYSTEM PACKAGE)**  
**HVAC SYSTEM**  
**STANDARD TECHNICAL SPECIFICATIONS**

**SPECIFICATION No: PE-TS-468-(571-13000-A)-A001**

**SECTION : I**

**SUB-SECTION : D**

**REV. 00**

**SECTION: I**  
**SUB-SECTION: D**  
**STANDARD TECHNICAL SPECIFICATIONS**

	<b>TECHNICAL SPECIFICATION</b>  <b>AIR HANDLING UNITS</b>	<b>SPECIFICATION NO.PES-553-02</b>	
		<b>VOLUME II B</b>	
		<b>SECTION D</b>	
		<b>REV. 02</b>	<b>DATE: 17.09.2012</b>
		<b>SHEET 1 OF 6</b>	

**STANDARD TECHNICAL SPECIFICATION  
FOR  
AIR HANDLING UNITS**

	<b>TECHNICAL SPECIFICATION</b>  <b>AIR HANDLING UNITS</b>	SPECIFICATION NO.PES-553-02	
		VOLUME II B	
		SECTION D	
		REV. 02	DATE: 17.09.2012
		SHEET 2 OF 6	
1.	<b><u>GENERAL</u></b>		
1.1	This specification covers the design, manufacture, Construction features, installation, commissioning, inspection and performance testing at site of AHUs.		
2.	<b><u>CODES AND STANDARDS</u></b>		
2.1	The design manufacture and performance of AHU shall comply with all currently applicable statutes, regulations and safety codes in the locality where the AHU is to be installed. The equipments shall also conform to the requirements of the latest editions of applicable Indian/British/US standards. Nothing in this spec. shall be construed to relieve vendor of this responsibility. In particular the equipment shall conform to the latest editions of the following standards:		
2.1.1	IS-659	:	Safety code for air conditioning
2.1.2	IS-660	:	Safety code for mechanical refrigeration
2.1.3	ASHRAE: Method of testing forced circulation air-cooling and air heating coils. standard 33		
2.1.4	ARI 41	:	Standard for forced circulation air cooling and air heating coils.
2.1.5	ARI 430/435	:	Air-cooling and air heating coils Central Station AHU / Application of Central Station AHU.
2.1.6	AMCA	:	211 and 311
	In case of any conflict in the standards and this specification the decision of PEM,BHEL shall be final and binding.		
3.	<b><u>CONSTRUCTION FEATURES</u></b>		
3.1	The casing of AHU shall be made of insulated double wall construction of min. 24 gauge galvanized sheet steel - IS 277 Gr. 120 (parent sheet: D/DD-IS-513) ribbed and reinforced for structural strength and rigidity with 25 mm thick polyurethane insulation of minimum 40 kg/m <sup>3</sup> density in between. The external wall will be pre-plasticised over GI coating on the outside. Angle irons or channel sections made of 16 gauge galvanized sheet steel shall be used for reinforcing. The casing shall be of sectionalized construction with proper sealing at the joints to make them air tight. Fan section and panels with bearing support shall be reinforced with heavy gauge channels (min. 5 mm thick). Suitable number of forged hot dip galvanized (610 gm/sq.m) U brackets shall be provided for AHU suspended from ceiling/roof.  Necessary arrangement shall be provided on the casing for measuring temperature and pressure in cooling/heating coil. Class of instruments shall be min. 2.		
3.2	Fan impeller shall be forwardly/backwardly inclined curved blade centrifugal type. Impeller shall be double width double inlet type. Fans shall be preferably low rpm (<=1500) to minimize vibration and noise. Noise shall be within 85 dB(A) at 1 metre distance from AHU casing. Max. Vibration level shall be acceptance and norms to be specified. Two to three wheels (impellers) shall be provided for each AHU. Impeller blades shall be fabricated from (min. 1.0 mm) galvanized/ epoxy powder coated sheet steel. Fan shall be of epoxy powder coated / galvanized sheet steel (min. 1.6		

	<b>TECHNICAL SPECIFICATION</b>  <b>AIR HANDLING UNITS</b>	SPECIFICATION NO.PES-553-02	
		VOLUME II B	
		SECTION D	
		REV. 02	DATE: 17.09.2012
		SHEET 3 OF 6	
	<p>mm) scroll with die formed inlets for uniform air flow. Fan shafts shall be solid cold rolled carbon steel (EN8 normalised), ground and polished. Fan shaft bearings shall be of heavy duty type selected for average operating life of 100,00 hours. Bearings shall be self-aligning, permanently lubricated type. Make of Brgs(SKF/FAG/NORMA/TATA) to be specified. Bearing Housing shall be of casting of min. IS Gr. 210, split type and suitably supported. The V-belt drive with belt guard shall be provided. Motors shall have minimum 15% margin over maximum BHP in working range.</p>		
3.3	<p>DX or chilled water cooling coils and steam/hot water coils shall be internally corrugated copper/ cupronickel tubes (as per manufacturer's standard) with smooth non corrugated external fins of aluminium (thickness 0.14 mm and grade 1100 as per spec) unless specified otherwise in specification. At least 5 fins /per cm. shall be provided. The chilled water/hot water coils shall have suitable (standardize class, size, threading) drain and vent connections.</p>		
3.4	<p>The filters in the filter section shall be provided as detailed in data sheet A.</p>		
3.5	<p>Humidifier shall be Pan type/as specified in the specification.</p> <p>Pan type Humidifier consisting of SS304/316 tank, heater, geyserstat with piping connection to supply air duct shall be provided unless specified otherwise in data sheet A.</p> <p>Heaters and branch line shall be of galvanized steel and nozzles shall be of brass (matl. grade) /SS 304.</p>		
3.6	<p>Condenser water from coil or surplus water from spray humidifier shall be collected in 16 gauge SS-304 pan. Minimum 50mm dia GI pipe nipple shall be provided on each end for drain connection. The drains for these points shall be extended to the main drain in AHU room. Condensate drain pipe (GI) of required length with sealing loop shall be provided and insulated as specified in the specification for insulation. Minimum requirement For GI Pipes and fittings shall be ERW/Seamless of medium thickness as per IS-1239/3589 and Hot dip galvanized</p>		
3.7	<p>Suitable number of Spring type vibration isolators shall be provided for fan and motor assembly. Neoprene rubber pads shall be provided below the AHU.</p> <p>The AHU shall be provided with 18 G SS drain pan.</p>		

	<b>TECHNICAL SPECIFICATION</b>  <b>AIR HANDLING UNITS</b>	SPECIFICATION NO.PES-553-02	
		VOLUME II B	
		SECTION D	
		REV. 02	DATE: 17.09.2012
SHEET 4 OF 6			

**4. TESTING AND INSPECTION AT MANUFACTURERS WORKS:**

List of TCs arranged as per Approved Quality Plan shall be furnished along with copy of TCs at the time of inspection.

	<b>TECHNICAL SPECIFICATION</b>  <b>AIR HANDLING UNITS</b>	<b>SPECIFICATION NO.PES-553-02</b>	
		<b>VOLUME II B</b>	
		<b>SECTION D</b>	
		<b>REV. 02</b>	<b>DATE: 17.09.2012</b>
		<b>SHEET 5 OF 6</b>	
4.1	Visual inspection of GI sheets and angles, channels etc. – dents, black spots, chipping of zinc coating, white dust on galvanised sheets shall be avoided. Pitting , lamination in angles and channels shall be avoided.		
4.2	Galvanised sheets - Test certificate shall be furnished for visual check, coating thickness, adhesion test, sheet thickness, uniformity of coating. For pipes and fittings compliance report shall be furnished by Manufacturer for visual check, coating thickness, adhesion test, sheet thickness, uniformity of coating.		
4.3	Shaft: Mechanical and chemical.		
4.4	Motors (of approved make): Routine TC.		
4.5	Workmanship and dimensional check as per manufacturing drg. and approved Drgs.		
4.6	Balancing of impellers- Dynamic balancing certificates shall be furnished –grade 6.3 or better to ISO-1940. Balancing weights shall be positively locked to avoid loosening. Balancing weights and fasteners used shall be galvanized.		
4.7	Performance test of one Centrifugal fan/per type/per size as per AMCA standard (for indigenous make).		
4.8	Centrifugal fans for AHUs will be 100% run tested by main contractor of BHEL. One centrifugal fan/per type/per size will be run tested. Vibration shall be within good zone of VDI 2056 / ISO 10816-1(group- K) machines when measured on bearing housing and noise level <85 dbA at 1 metre distance. Max. Temp. on bearing housing- 40 degrees Centigrade + ambient.		
4.9	Complete assembly of one AHU/per type/ per size (excluding cooling coil and filter) shall be witnessed.		
4.10	Run test of one complete assembly/per type/per size (excluding cooling coil and filter). Vibration shall be within satisfactory zone of VDI 2056 / ISO 10816-1(group- K) machines when measured on bearing housing and noise level <85 dbA at 1 metre distance. Max. Temp. on bearing housing- 40 degrees Centigrade + ambient.		

	<b>TECHNICAL SPECIFICATION</b>  <b>AIR HANDLING UNITS</b>	SPECIFICATION NO.PES-553-02	
		VOLUME II B	
		SECTION D	
		REV. 02	DATE: 17.09.2012
		SHEET 6 OF 6	

**5. DRAWINGS/DOCUMENT/DATA REQUIRED AFTER AWARD OF CONTRACT**

- 5.1 GA drawing of AHU & data- sheet to be submitted along with technical schedules enclosed in Volume III.
- 5.2 Drawing including equipment layout, foundation & loading details etc. for civil works. These drawings must cover sufficient details so that design of civil works can be completed.
- 5.3 Inspection, operation & Maintenance Manuals.
- 5.4 Equipment description giving complete design calculations, basis of design, selection criteria etc.
- 5.5 Test Certificates.
- 5.6 Final as built documentation i.e. final-version of all drawings, data & information as per the requirement specified elsewhere.
- 5.7 Performance Test Certificates.



## AIR HANDLING UNIT

DATA SHEET - A

VOLUME - II-B

SECTION - D

REV 00

DATE 17.09.2012

SHEET 1 OF 2

DESCRIPTIONDATA

- |  |  |
|--|--|
| 1. Nos. required/working                           | : Refer to Section-C of Specific technical requirement.                      |
| 2. Location  | : Refer to Section-C of Specific technical requirement.                      |
| 3. Service/type                                    | : Air Conditioning /Double skin.   |
| 4. Fan type  | : Centrifugal (forward/backward curve Blade) limit load.                     |
| a) Capacity  | : To Suit as per calculation.  |
| b) Static pressure                                 | : To suit but not less than 60 mm wc for AHU's Micro-V filters.              |
| c) Discharge direction                             | : To suit layout.  |
| d) Motor   | : By Bidder,   |
| e) Local push button station (Start/Stop)          | : By Others  |
| f) Motor location                                  | : Inside AHU Casing.   |
| g) Drive   | : Belt, pulley, belt guard.  |
| 5. Face and Bypass Damper                          | : Required (Opposed blade type) DX AHU's having                              |
| 6. Cooling coil                                    |  |
| a) Duty sensible heat                              | : To suit as per calculations  |
| b) Duty latent heat                                | : -do-   |
| c) Type of coil                                    | : Chilled Water/DX/Hot Water.  |
| d) No. of rows                                     | : To suit but not less than four (4)   |
| e) Material of tube /Thickness                     | : Seamless Copper to ASTM E-75/Equivalent.                                   |
| f) Material of fins                                | : Aluminium to SAE-1100-/1145-0  |
| g) Number of fins                                  | : Not greater than 5 per cm (13 per inch).                                   |
| h) Max. face velocity                              | : 2.5 m/sec.   |
| i) Air flow quantity                               | : To suit as per tender drawings/documents.                                  |
| 7. 3 - way motorised mixing valve with thermostat. | : Required with thermostat & actuator for chilled water system for each AHU. |





**AIR HANDLING UNIT**  
**DATA SHEET - A**

VOLUME - II-B

SECTION - D

REV 00

DATE 17.09.2012

SHEET 2 OF 2

- |     |                              |  |
|-----|------------------------------|--|
| 8.  | Damper at discharge          | : Manually operated at discharge of each AHU outlet.   |
|     | a) Material of construction  | : Mild Steel, galvanised.  |
| 9.  | Filters (Pre-filters)        |  |
|     | a) Type & thickness          | : Dry panel type/ 50 mm  |
|     | b) Filter area.              | : To suit as per velocity requirements. "V" - Bank.  |
|     | c) Filter efficiency         | : Average arrestance efficiency of 65-80 %   |
|     | d) Press drop (Clean)        | : Not to exceed 2.5 mmwc when clean & 6.5 mmwc while dirty.  |
| 10. | Humidification section       | : As per the System requirement.   |
|     | a) Type                      | : Pan type, unless otherwise specified.  |
|     | b) Operation                 | : Automatic with Humidification.   |
| 11. | Fresh air arrangement        | : Required.  |
|     | a) Fresh air fan             | : Tube axial flow fans with motor.   |
|     | b) Accessories               | : i) Inlet cone with Bird screen.<br>: ii) Dry panel pre-filters,<br>: iii) High efficiency filters for control room areas.<br>: iv) Volume Control Dampers,<br>: v) Supports etc.   |
| 12. | Vibration isolator required. | : Yes  |
| 13. | Type of vibration isolator.  | : Neoprene ribbed Rubber for AHU's.  |
| 14. | Any other requirement        | : i) In addition to dry panel filters on AHU, High efficiency filters(average arrestance efficiency of 80-90 %) shall be provided in supply air duct side of AHU for all control room and allied areas.<br><br>: ii) Bidder to also provide suitable electrical strip heaters for winter heating & monsoon reheating with Contactor box etc. Heaters to be interlocked with airstat. |
| 15. | Instrument & controls        | : Lot.(including Control box for strip heaters, pan humidifiers etc. in each AHU room.)  |
| 16. | Insulation of drain piping   | : Lot.   |

	<b>TECHNICAL SPECIFICATION</b>  <b>LOW PRESSURE AIR DISTRIBUTION SYSTEM</b>	SPECIFICATION NO.PES-553-07	
		VOLUME II B	
		SECTION D	
		REV. 02	DATE: 17.09.2012
SHEET 1 OF 9			

**STANDARD TECHNICAL SPECIFICATION**  
**FOR**  
**LOW PRESSURE AIR DISTRIBUTION SYSTEM**

	<b>TECHNICAL SPECIFICATION</b>		SPECIFICATION NO.PES-553-07		
	<b>LOW PRESSURE AIR DISTRIBUTION SYSTEM</b>		VOLUME II B		
			SECTION D		
			REV. 02	DATE: 17.09.2012	
		SHEET 2 OF 9			
<b>1.</b>	<b><u>GENERAL</u></b>				
1.1	This specification covers the design, manufacture, construction features, installation, inspection testing and air balancing of air distribution system upto a total pressure of 95mm w.g. The specification is intended to cover the air distribution for air conditioning system and ventilation system not involving localised exhaust.				
<b>2.</b>	<b><u>CODES AND STANDARDS</u></b>				
2.1	The design, construction and performance of complete system shall conform to all currently applicable statutes, regulations, safety codes in the locality where the equipment are to installed				
2.2	Unless specified otherwise the equipments shall generally conform to latest applicable Indian Standards. Nothing in this specification shall be construed to relieve the vendor of this responsibility. In particular the equipment shall generally conform to latest editions by the following standards:-				
	a)	IS: 655	-	Specifications for metal air ducts.	
	b)	IS:277	-	Specifications for galvanised steel sheets.	
	c)	IS:737	-	Specification for wrought aluminium and aluminium alloy sheet and strip.	
<b>3.</b>	<b><u>MATERIAL</u></b>				
3.1	Metal air ducts shall be either of galvanised steel sheets or aluminium sheets, as indicated in data sheet-A.				
3.2	The rolled steel sheets before galvanising shall be properly annealed or normalised so as to allow fabrication of ducts without developing cracks. Zinc coating on the steel shall be as per technical requirement refer to Section-C of Specific Technical Requirements.				
3.3	The aluminium sheets shall be of grade S1C or NS3 and shall be suitable for duct fabrication work as per IS-737 latest				
<b>4.</b>	<b><u>CONSTRUCTION/FABRICATION</u></b>				
4.1	The thickness of sheets, the type of bracing and other fabrication details shall generally conform to requirements given hereunder unless specified otherwise in data sheet A and/or indicated on drawings.				
4.2	<b>RECTANGULAR DUCTS</b>				
4.2.1					
	S.No.	Max Side	Sheet Thickness	Type of transverse	Bracings

	<b>TECHNICAL SPECIFICATION</b>  <b>LOW PRESSURE AIR DISTRIBUTION SYSTEM</b>	SPECIFICATION NO.PES-553-07	
		VOLUME II B	
		SECTION D	
		REV. 02	DATE: 17.09.2012
SHEET 3 OF 9			

		(mm) GI	(mm) AI	Joint connections	
a)	Up to 600	0.63 (24G)	0.80	S-drive, pocket or bar slips or flanged joints on 2.5m centres	None
b)	601 to 750	0.63 (24G)	0.80	S-drive, 25mm pocket or 25mm bar slips or flanged joints on 2.5m centres	25x25x3 mm MS angles, 1.2m from joints
c)	751 to 1000	0.80 (22G)	1.00	S-drive, 25mm pocket or 25mm bar slips or flanged joints on 2.5m centres	25x25x3 mm MS angles, 1.2m from joints
d)	1001 to 1500	0.80 (22G)	1.00	40x40x3mm MS angle, flanged connections or 40mm pocket or 40mm bar slips with 35x3mm bar reinforcing on 2.5m centres	40x40x3 mm MS angles, 1.2m from joints
e)	1501 to 2250	1.00 (20G)	1.50	40x40x3mm MS angle, flanged connections or 40mm pocket or 40mm bar slips, 1M maximum centres, with 35x3mm bar reinforcing	40x40x3 mm diagonal angles or 40x40x3mm angles, 600mm from joints
f)	2251 & above	1.25 (18G)	1.80	50x50x3mm MS angles, connections or 40mm pocket or 40 mm bar slips, 1M maximum centres with 35x3mm bar reinforcing.	50x50x3mm diagonal angles or 50x50x3mm angles 600 mm from joints.
g)	No bracing is required if transverse joints are less than 600mm apart				
h)	For ducts larger than 2250mm, special handling and supporting methods shall be provided as per the approval of Purchaser				

- 4.2.2 All rectangular ducts having either dimension larger than 450mm shall be cross broken except these ducts which are insulated with sand cement plaster. Air outlet connections on ducts need not be cross broken.
- 4.2.3 The seams on duct cones shall be of Pittsburgh type. Longitudinal seams shall be smooth inside the ducts.
- 4.2.4 The flanges used for transverse joints shall be joined together with GI bolts (grade 4.6) and nuts spaced at 125mm centres as per following:
- Upto 1000mm - 6 mm dia GI bolts
  - 1001 to 1500 - 8 mm dia GI bolts
  - 1501 and above - 10mm dia GI bolts

	<b>TECHNICAL SPECIFICATION</b>  <b>LOW PRESSURE AIR DISTRIBUTION SYSTEM</b>	SPECIFICATION NO.PES-553-07	
		VOLUME II B	
		SECTION D	
		REV. 02	DATE: 17.09.2012
SHEET 4 OF 9			

4.2.5 The MS angle flanges shall be connected to ducts with rivets at approx. 100mm centres. The flanged joints shall have 6mm thick felt packing stuck to flanges with shellac varnish. The holes in the felt packing shall be burnt through. The ducts are to be tapped 6mm across the MS flanges.

4.2.6 MS angles used for bracings shall be tack welded to the ducts or rivetted at 125mm centres, as applicable.

### 4.3 ROUND DUCTS

#### 4.3.1

S.No.	Duct dia-mm	Sheet Thickness		Reinforcing
		(mm)	(mm)	
		GI	Al	
a)	Up to 150	0.63 (24G)	0.80	None
b)	151 to 600	0.80 (22G)	1.00	None
c)	601 to 1000	1.00 (20G)	1.50	40x40x3mm girth MS
d)	1001 to 1250	1.00 (20G)	1.50	40x40x3mm girth MS angles at 2.0 meter centres
e)	1251 & above	1.25 (18G)	1.80	40x40x3mm girth MS angles at 1.2m centres

4.3.2 The seams on round ducts may be continuously welded or grooved longitudinal seam. In case of welding of GI sheet, zinc rich paint shall be applied on the welded zone.

4.3.3 Round ducts shall either be joined by welding or the ducts shall be swedged 40mm from the ends such that larger end will butt against the swedge and is held in place with sheet metal screws.

#### 4.4 DUCT SUPPORTS

Unless specified otherwise on drawings, rectangular ducts with larger side of 2250mm or above shall be supported by 15mm MS rods and 50x50x3mm and MS angles while those below 2250 mm shall be supported by 10mm MS rods and all angles shall be given a coat of primer paint. The duct supports shall be at a distance not exceeding 1800mm. The MS rods shall be fixed to MS angle cleats, which in turn are fixed to ceiling slab by suitable anchor fasteners. All anchor fasteners, MS angle cleats, coach screws, hooks and other supporting material required shall be provided by vendor.

However, If ducts are thermally insulated, the MS angles and supports shall not be in

	<b>TECHNICAL SPECIFICATION</b>  <b>LOW PRESSURE AIR DISTRIBUTION SYSTEM</b>	SPECIFICATION NO.PES-553-07	
		VOLUME II B	
		SECTION D	
		REV. 02	DATE: 17.09.2012
		SHEET 5 OF 9	
		<p>direct contact with ducts, for which purpose wooden pieces/ Resin bonded fibre glass sheets (50 mm thick) shall be used in between.</p>	
4.5	<b>FLEXIBLE CONNECTIONS</b>  Wherever the sheet metal ducts connects to intake or discharge of fan units a flexible connection of at least 150mm width made by closely woven double layer Fire resistant or canvas shall be provided. The same shall be attached to angle iron frames on equipment and to similar frame on duct or casing by means of a steel band 9r (or) collar fitting over the end of the flexible connection and bolted through angle iron frame so as to clamp securely between the band and the angle frame.		
4.6	<b>TRANSFORMATIONS AND BREACHES</b>  All curves, bends, offsets and other transformations shall be made for easy and noiseless flow of air. The throat of every branch duct shall be sized to have a velocity not exceeding that in the main duct to which the branch is connected.		
4.7	<b>CAULKING</b>  Wherever duct passes through wall, the opening between masonry and duct work shall be neatly caulked or sealed to prevent movement of air from one space to adjoin by space with a rated fire resistant material.		
4.8	<b>EASEMENT</b>  Normally pipe hangers, light fitting rods etc. shall not be allowed to pass through the ducts. Wherever, It becomes absolutely essential to pass these hangers/rods etc. Through the ducts, prior approval of purchaser shall be taken and light streamlines easement around the same shall be provided to maintain smooth air flow.		
4.9	<b>ACCESS DOORS</b>  Access doors shall be provided in ducts, plenums etc. on both sides to allow access and servicing of equipment viz. pipes, dampers, coils, valves, heaters etc.  All access doors shall be adequately sized and lined suitably with felt to prevent air leakage. The doors shall be of built-up construction, structurally strong and shall have at least two hinges each, and shall be with two rust proof window sash locks of approved type. All doors shall be so set as to flush with outer finish of duct insulation etc.		
4.10	<b>DAMPERS AND SPLITTERS</b>		
4.10.1	Dampers and splitters shall be provided at suitable points for proportional volume control of the system. Splitters and dampers shall be made of minimum 18 gauge GSS of quadrant type with locking device mounted outside the duct at accessible location.		
4.10.2	<b>FIRE DAMPERS</b>  Fire dampers shall be provided as specified in Data Sheet -A and shall be installed at locations indicated on drawings and/or as required/approved by purchaser, including all openings in passage of duct work through fire walls and floors etc. The fire damper shall be of electrical type with damper motor actuated by thermal		

	<b>TECHNICAL SPECIFICATION</b>  <b>LOW PRESSURE AIR DISTRIBUTION SYSTEM</b>	SPECIFICATION NO.PES-553-07	
		VOLUME II B	
		SECTION D	
		REV. 02	DATE: 17.09.2012
		SHEET 6 OF 9	
		<p>sensor or fusible link type.</p>	
<b>4.10.3</b>	<b>VANES</b>	<p>Unless otherwise shown in the drawings all elbows shall be such that the throat radius is 75% of the duct width. In case throat radius is smaller, suitable single thickness vanes of approved details shall be provided.</p>	
<b>4.10.4</b>	<b>FLASHING</b>	<p>For the ducts penetrating roofs or outside walls, provision of flashing shall be made by the ducting vendor.</p>	
<b>4.11</b>	<b>DIFFUSERS AND GRILLS</b>	<p>The type and quantity of diffusers and grills is indicated on enclosed drawings/data sheet A. The size/quantity of diffusers/ grills indicated in the drawing/data sheet is indicative and is for vendor's reference purpose only. Vendor shall ensure that the diffusers/grills offered are of requisite capacity, throw and terminal velocity. The pressure drop and noise levels shall be as per data sheet. A enclosed. The diffusers/grills shall be approved by purchaser.</p> <p>Unless specified otherwise the diffusers/grills shall be of mild steel land painted with two coats of primer paint. Supply air grills shall be complete with volume control dampers. Supply air grills shall be double deflection type while Return Air grills can be single deflection type. Ceiling outlets/diffusers shall have volume control dampers, fixed grids and blanking baffles. All volume control dampers shall be operated by a key from the front of grills/diffusers.</p> <p>Suitable vanes shall be provided in duct collars to have uniform air distribution. Blank-off baffles wherever required, shall also be provided.</p>	
<b>4.12</b>	<b>PLENUMS AND RA BOXING</b>	<p>All plenum chambers and/or connections to fans, dampers etc. shall be constructed in 18 gauge GI sheet. supported on 40x40x6mm MS angle frames. All vertical angles shall be riveted at appox. 125mm. centres to the casing. Suitable caulking compound (Pecora or equivalent) shall be inserted between the base of the angle and all masonry construction to which angles are fastened.</p> <p>Return air boxing requirements if any are indicated in data sheet-A and the same shall be provided by vendor. The return air box shall be fabricated out of GI sheets shall be insulated with 25mm thick fibre-glass.</p>	
<b>4.13</b>	<b>ACCOUSTIC LINING</b>	<p>The ducts shall be lined acoustically from inside as given in data- sheet A and/or section C of the specification.</p>	
<b>4.14</b>	<b>PAINTING</b>	<p>Wherever specified the ducts shall be painted or lined with suitable anti-corrosive paint/ lining as per approval of purchaser. In particular the ducts coming in contact with acid fumes shall be epoxy coated, inside and outside.</p>	

	<b>TECHNICAL SPECIFICATION</b>  <b>LOW PRESSURE AIR DISTRIBUTION SYSTEM</b>	SPECIFICATION NO. PES-553-07	
		VOLUME II B	
		SECTION D	
		REV. 02	DATE: 17.09.2012
		SHEET 7 OF 9	
4.15	<b>THERMAL INSULATION</b>  Thermal insulation shall be as per data sheet - A and the insulation shall conform to enclosed spec. no. PES-553-08.		
5.	<b><u>INSPECTION AND TESTING</u></b>		
5.1	<b>INSPECTION &amp; TESTING DURING FABRICATION</b>		
5.1.1	Visual inspection of GI sheets and angles, channels etc. – dents, black spots, chipping of zinc coating, white dust on galvanised sheets shall be avoided. Pitting, lamination in angles and channels shall be avoided.		
5.1.2	Galvanised sheets - Test certificate shall be furnished for visual check, coating thickness, adhesion test, sheet thickness, uniformity of coating.		
5.1.3	Check for dimensions & mass as per latest IS-277.		
5.1.4	Check for defect, twists, ungalvanised spots as per IS-2629.		
5.1.5	Bend test & wrapping test as per IS-277.		
5.1.6	Zinc coating test on samples as per IS-6745.		
5.2	<b><u>INSPECTION &amp; TESTING AT SITE.</u></b>		
5.2.1	The duct branches, elbows etc. shall be inspected and the joints and connections etc, are to be checked before they are assembled in position.		
5.2.2	After completion, all duct systems shall be checked and tested for air leakage, tightness, velocity, pressure drop, vibration and noise etc.		
6.	<b><u>BALANCING</u></b>		
6.1.1	The entire air distribution system shall be balanced by vendor to supply the air quantities as required in various rooms so as to maintain the requisite temperature and air flow in the conditioned spaces. The final balance of air quantities through each grill/diffuser etc. shall be recorded and submitted to purchaser for approval. Proper steps shall be taken to have a uniform temperature in all enclosures, with utmost care for noise level to be within tolerance limit		
6.1.2	All instruments required for testing/balancing etc. of the air distribution system shall be provided by vendor.		



	<b>TECHNICAL SPECIFICATION</b>  <b>LOW PRESSURE AIR DISTRIBUTION SYSTEM</b>	SPECIFICATION NO.PES-553-07	
		VOLUME II B	
		SECTION D	
		REV. 02	DATE: 17.09.2012
SHEET 8 OF 9			

**7. DATA TO BE FURNISHED BY VENDOR AFTER THE AWARD OF CONTRACT**

- 7.1 Fabrication drawings of ducts and grilles, louvers, dampers, etc, including typical details of grilles dampers etc.
- 7.2 Test certificates in line with scope of inspection.
- 7.3 Other dimensional drawings & documents as may be required by purchaser for better understanding of the system & for preparation of operation, maintenance & instruction manual.

	<b>TECHNICAL SPECIFICATION</b>  <b>LOW PRESSURE AIR DISTRIBUTION SYSTEM</b>	<b>SPECIFICATION NO.PES-553-07</b>	
		<b>VOLUME II B</b>	
		<b>SECTION D</b>	
		<b>REV. 02</b>	<b>DATE: 17.09.2012</b>
		<b>SHEET 9 OF 9</b>	



## LOW PRESSURE AIR DISTRIBUTION SYSTEM

### DATA SHEET - A

VOLUME II-B

SECTION D

REV 00

DATE 17.09.2012

SHEET 1 OF 2

#### Description

#### Data

- |   |   |
|---|---|
| 1. General (List of areas)  | : As per Specification/Tender drawing.  |
| 2. GSS Duct Work<br>a) Type   | : GSS as per IS: 277<br>(Zinc coating as per Section-C of Specific Technical Requirements.)   |
| b) Size   | : As per Section-C of Specific Technical Requirements and bill of quantity.   |
| 3. Acoustic lining  | : Up to 5m length from AHU Outlet.  |
| 4. Special painting   | : Galvanised.   |
| 5. Thermal Insulation   | : Required in supply air duct in AC entire length.  |
| 6. Diffusers (Circular/Square)<br>300 mm size<br>350 mm size<br>450 mm size<br>550 mm size<br>600 mm size<br>Any other size | : Bidder to estimate as per drawings./specification.<br>All grille frame and louvers shall be manufactured of at least 16 SWG Aluminium |
| 7. SA grilles (for each size)   | : To suit air flow as per System requirements / Tender Drawings.  |
| 8. RA grilles (for each size)   | : -do-  |

#### NOTE:

1. Duct sheet thickness shall be as per IS-655
2. Opposed blade type volume control damper shall be provided at each supply air diffusers/grilles.
3. Bidder to provide suitable gasketing at each duct flange.
4. Fire damper shall be motor operated type, when otherwise specified under Section-C.
5. Access door in ducting system shall be provided as required.
6. MS Angle (painted) shall be used for duct supports etc.
7. Velocity thru duct shall normally not exceed 9.0 M/sec for Air conditioning system. Maximum velocity (outlet) for supply air diffuser shall not exceed 2.5 m/sec.

**LOW PRESSURE AIR DISTRIBUTION SYSTEM****DATA SHEET - A**

VOLUME II-B

SECTION D

REV 00

DATE 17.09.2012

SHEET 2 OF 2

8. All Grilles & diffusers shall be supported with frame. Frame etc. shall be supplied by bidder.



**PACKAGE-CONDITIONING UNIT**

**DATA SHEET - A**

VOLUME II-B

SECTION D

REV 00

DATE 17.09.2012

SHEET 1 OF 1

**DESCRIPTION**

**DATA**

- |  |   |
|--|---|
| 1) Capacity of the unit at operating conditions.                                 | : As specified  |
| 2) Numbers required  | : Refer to Section-C of Specific Technical Requirements                 |
| 3) Designation of the unit   | : Package AC Unit   |
| 4) Whether air cooled/water cooled   | : Refer to Section-C of Specific Technical Requirements                 |
| 5) The plant shall be suitable for maximum-ambient temp.                         | : Refer outdoor design condition as specified.                          |
| 6) Whether a plenum Chamber required   | : Units shall be connected to fresh air ducts.                          |
| OR   |   |
| Whether to be connected duct system.   | : Yes.  |
| 7) Whether Humidifier required for humidity-control.                             | : Refer to Section-C of Specific Technical Requirements                 |
| 8) Whether strip heaters required for winter heating.                            | : Refer to Section-C of Specific Technical Requirements                 |
| 9) Whether strip heater required for Humidity control.                           | : Refer to Section-C of Specific Technical Requirements                 |
| 10) Final painting colour shade  | : Subject to approval / during detail engineering stage.                |
| 11) Whether fan static pressure is to be designed for filters arrangement shown. | : Yes.  |
| 12) Installation supporting structure/drain piping, insulation.                  | : Required. Drain piping with insulation up to the nearest drain point. |
| 13) Controls & Instruments   | : Yes (Lot)   |
| 14) Isolation Switch   | : Yes   |



**STANDARD TECHNICAL SPECIFICATION  
FOR  
AIR FILTER**

**SPECIFICATION NO.PES-553-06**

**VOLUME II B**

**SECTION D**

**REV. 02      DATE: 17.09.2012**

**SHEET 1 OF 4**

**STANDARD TECHNICAL SPECIFICATION  
FOR  
AIR FILTER**

	<b>STANDARD TECHNICAL SPECIFICATION FOR AIR FILTER</b>	SPECIFICATION NO.PES-553-06	
		VOLUME II B	
		SECTION D	
		REV. 02	DATE: 17.09.2012
		SHEET 2 OF 4	
1.	<p><b><u>GENERAL</u></b></p> <p>This specification covers the design, manufacture, inspection and testing at manufacturer's work or his sub-contractor's works of Air filters to be used for air-conditioning and ventilation system.</p>		
2.	<p><b><u>CODES AND STANDARDS</u></b></p> <p>This design, manufacture and performance of AIR FILTERS shall comply with all currently applicable statutes, regulation and safety codes in the locality where the equipment will be installed. The equipment shall also conform to latest applicable Indian/British/USA standards. Nothing in this specification shall be construed to relieve the vendor of this responsibility. The following standards, in particular, shall be applicable for certified ratings of filters and for conducting performance test, if required.</p> <p>a) BS EN - 779 -Methods of test for air filters used in air conditioning and general ventilation.</p>		
3.	<p><b><u>GENERAL</u></b></p> <p>The enclosed Data sheet A gives the type and other particulars of filters required.</p>		
3.1	<p><b>POLY FIBRE AIR FILTERS</b></p> <p>Filtering media shall consist of a suitable fibrous material (e.g. polyethylene extruded sections coir etc.) packed into a 20 gauges GSS framework, complete with handles etc. The filter element shall be supported by galvanised steel wire mesh of 10mm. sq. on either side, Velocity across the filters shall not exceed 2.5 M/sec. Average efficiency Em (%) shall be <math>\geq 80</math> as per BS EN - 779.</p>		
3.2	<p><b>DRY FABRIC AIR FILTERS</b></p> <p>Filter element shall be pressed felt filter fabric or suitable material recommended by the manufacturer, stitched on to galvanised wire gauge support and crimped to form deep folds. Suitable aluminium spacers shall be provided to ensure uniform distribution of air flow through filters. Filter casing shall be provided with neoprene sponge rubber sealing, The filter shall have Average efficiency Em (%) of <math>\geq 95</math> as per BS EN - 779.</p>		
3.3	<p><b>PANEL TYPE METALLIC FILTERS (DRY/VISCOUS)</b></p> <p>Filter shall consist of V-fold galvanised wire mesh interspaced with flat layers of galvanised wire mesh. The density of media shall increase in the direction of air flow. Edges of wire mesh shall be suitably hemmed to prevent abrasion during handling. The media shall be supported on either side by galvanised expanded metal casing. The framework shall be at least 18 gauge GSS. Filter shall be either dry or wetted type as per data sheet=A. The oil shall be mineral oil of approved quality and make. As a the filter frame made of Aluminium alloy conforming to IS:737 can be considered unless use of aluminium is prohibited otherwise due to site conditions being saline/corrosive.</p> <p>All filters shall be capable of being cleaned of their accumulated dust by tap water flushing. The dry metallic filter shall have Average arrestance Am (%) shall be <math>\geq 90</math>.</p>		

	<b>STANDARD TECHNICAL SPECIFICATION FOR AIR FILTER</b>	SPECIFICATION NO.PES-553-06	
		VOLUME II B	
		SECTION D	
		REV. 02	DATE: 17.09.2012
		SHEET 3 OF 4	
<p>However oil wetted air filters shall have Average Efficiency Em (%) <math>\geq</math> 90 as per BS EN - 779..</p>			
3.4	<p><b>AUTOMATIC CLEANING FILTERS</b></p> <p>This shall consist of a filter mat and drop eliminator, driven by a suitably rated geared motor unit being supported on a steel framework. The filter mat shall consist of an endless steel wire mat insets of steel mesh held between an upper &amp; a lower shall drop eliminator shall consist of an endless steel wire without insets of steel mesh. The unit shall include a suitable oil pump, gludge raking mechanism and sludge container and tensioning device. Pressure drop shall be limited to 0.5 / mm WG when clean &amp; 10 mm when dirty. Air velocity across filter shall not exceed 3 M/sec.</p>		
3.5	<p><b>ABSOLUTE FILTERS</b></p> <p>Filters shall be constructed by pleating a continuous sheet of filter medium into closely spaced pleats separated by heavy corrugated aluminium spacers. They shall be individually tested and certified to have an efficiency of not less than 99.97% when tested with 0.3 micron dioctylphalate smoke as per IS:2831. The clean filter initial static pressure drop shall not be greater than 25mm WC at rated capacity. A neoprene sponge rubber sealing shall be provided on either face of filter frame.</p>		
3.6	<p><b>WATER REPELLANT NYLON FILTERS</b></p> <p>This shall be constructed of water repellent nylon fabric with continuous water spraying on it from a header for keeping it clean. Efficiency of this filter shall be 85% down to 10 microns. This filter shall be used for unitary air filtration system only.</p>		
4.	<p><b><u>INSPECTION &amp; TESTING</u></b></p> <p>The scope of inspection for air filters shall be as below:</p>		
4.1	Dimensional inspection of frame & filter media.		
4.2	<p>Witnessing of type tests on one per type per size air filters for the following properties.</p> <p>a) Gravimetric efficiency.</p> <p>b) Pressure drop in clean &amp; dirty (choked - %age to be specified ) condition.</p> <p>c) Efficiency as per BS EN - 779.</p>		
4.3	Verification of type test certificates for similar type & size of filters for sodium flame test as per BS-3928 (if applicable- refer data sheet).		





**STANDARD TECHNICAL SPECIFICATION  
FOR  
AIR FILTER**

**SPECIFICATION NO.PES-553-06**

**VOLUME II B**

**SECTION D**

**REV. 02      DATE: 17.09.2012**

**SHEET 4 OF 4**

**5.                    DATA TO BE FURNISHED BY VENDOR AFTER AWARD OF CONTRACT**

- 5.1                    GA Drawing.
- 5.2                    Drawing showing material/construction detail
- 5.3                    Installation and\service manual
- 5.4                    Rating curves/charts
- 5.5                    Test certificates
- 5.6                    Elect. diagrams (when automatic cleaning type)



**AIR FILTER**  
**DATA SHEET - A**

VOLUME II-B

SECTION D

REV 00

DATE 17.09.2012

SHEET 1 OF 1

**DESCRIPTION****DATA****1) General**

1.1 Service	: Air Conditioning.
1.2 Location	: Central Air conditioning plant, & package AC plant, fresh air fan system. Also for split AC.
1.3 Nos.	: Refer Section 'C' of Specification.
1.4 Total air flow/type	: Refer Section 'C' of Specification.
1.5 Temperature	: As per project information.
1.6 Relative Humidity	: 100%
1.7 Gas Composition	: Atmospheric Air (Dusty) as prevalent in power Station.
1.8 Filter Media	: Synthetic non-woven
1.9 Efficiency	: Average arrestance efficiency of 65-80 % for Dry Panel filter (pre-filters) and average arrestance Efficiency of 80-90 % for fine filters.
1.10 Allowable pressue drop	: 2.5 mm & 6.5 mm in clean and dirty condition respectively for dry panel filters(prefilters). 12 mm in clean condition for fine filters.
1.11 Frame Work	: 18 G, GSS.
1.12 Mounting	: Ladder Type M.S Angles (galvanised)
1.13 Size	: 600 x 600 mm

Note:-

- 1) Face velocity of air across the filters shall not exceed 2.5 m/sec.

	<b>TECHNICAL SPECIFICATION</b>  <b>THERMAL INSULATION FOR COLD SURFACES</b>	<b>SPECIFICATION NO.PES-553-08</b>	
		<b>VOLUME II B</b>	
		<b>SECTION D</b>	
		<b>REV. 02</b>	<b>DATE: 17.09.2012</b>
<b>SHEET 1 OF 6</b>			

**STANDARD TECHNICAL SPECIFICATION  
FOR  
THERMAL INSULATION FOR COLD SURFACES**

	<b>TECHNICAL SPECIFICATION</b>  <b>THERMAL INSULATION FOR COLD SURFACES</b>	SPECIFICATION NO.PES-553-08	
		VOLUME II B	
		SECTION D	
		REV. 02	DATE: 17.09.2012
		SHEET 2 OF 6	
1.	<p><b><u>SCOPE</u></b></p> <p>This specification covers design, manufacture, testing at manufacturers works, supply, application &amp; finishing of insulation for cold piping, air conditioning ducting &amp; equipment for low temperature service.</p>		
2.	<p><b><u>CODES &amp; STANDARDS</u></b></p> <p>The design, manufacture and performance of materials covered under this specification shall comply with all currently applicable statues, regulations &amp; safety codes in the locality where the equipment/material are to be installed. The material shall also conform to the latest applicable Indian/British/American codes &amp; standards. Nothing in this specification shall be construed to relieve the vendor of his responsibility. In particular, the material shall conform to the latest editions of the following standards :-</p> <p><b>IS:3069: GLOSSARY OF TERMS &amp; SYMBOLS &amp; UNITS RELATING TO THERMAL INSULATION</b></p> <p style="padding-left: 40px;">materials.</p>		
2.1	IS:4671 : Expanded polystyrene for thermal insulation purposes.		
2.2	IS:3677 : Mineral wool for thermal insulation.		
2.3	IS:8183 : Resin bonded mineral wool.		
3.	<p><b><u>DESIGN REQUIREMENTS</u></b></p>		
3.1	The insulating material as well as protective covering shall be new & unused, non-corrosive, vermin/rodent proof and shall be guaranteed to withstand continuously & without deterioration the maximum/minimum temperatures to which they may be subjected to, under specified site conditions.		
3.2	The insulation material must be light weight, strong, free from shots & coarse fibre & shall provide high insulation efficiency at low weight & coat. It should be non-hygroscopic & should not rot. It shall not settle or shake down even when subjected to prolonged vibrations.		
3.3	The insulation material, density and thickness etc. Shall be as specified in DATA SHEET A.		
4.	<p><b><u>APPLICATION DETAILS</u></b></p>		
4.1	The surface to be insulated shall be thoroughly cleaned and allowed to dry. Pressure/hydrostatic tests, if any, shall be carried out before application of insulation.		
4.2	A layer of solvent free, anticorrosive paint shall be applied & allowed to dry.		
4.3	Hot industrial bitumen of grade 85/40 or 85/25 conforming to latest IS:702 shall be uniformly applied @ 1.5 kg/sq.m on the surface to be insulated. A similar layer shall also be applied on the inside surface & edges of the insulation. A suitable cold adhesive compound may also be used in place of bitumen.		
4.4	Insulation in the form of pipe sections/rolls slabs of specified density & thickness shall be stuck to the coated surface with joints staggered & well butted & secured. The adjoining sections shall be tightly pressed together. All the joints shall be sealed with		

	<b>TECHNICAL SPECIFICATION</b>  <b>THERMAL INSULATION FOR COLD SURFACES</b>	SPECIFICATION NO.PES-553-08	
		VOLUME II B	
		SECTION D	
		REV. 02	DATE: 17.09.2012
		SHEET 3 OF 6	
	<p>bitumen/equivalent adhesive. Voids if any shall be packed with suitably cut pieces of insulation material.</p> <p>4.5 In case of double layer application both circumferential &amp; longitudinal joints shall be suitably staggered.</p> <p><b>5. VAPOR SEALING &amp; INSULATION FINISH</b></p> <p>The insulation shall be treated for vapor sealing &amp; weather proofing &amp; finished as specified in DATA SHEET A The acceptable types of finishes are outlined below:-</p> <p><b>5.1 FINISHING SYSTEM I: EXTERNAL INSULATION WITH PLASTER FINISH</b></p> <p>5.1.1 A thick vapor seal of hot bitumen @ 2.5 kg/Sqm shall be applied on the outer surface of insulation &amp; allowed to dry.</p> <p>5.1.2 The surface shall then be wrapped with 20mm (3/4" _ hexagonal mesh of 24 SWG GI wire, butting all the joints &amp; laced down with 22 SWG GI lacing wire.</p> <p>5.1.3 12.5mm (1/2 inch) thick sand cement plaster in the ratio of (1:1) shall be applied in two layers, the second layer being brought to a smooth finish. A water proofing compound shall be added to the cement before its application.</p> <p><b>5.2 FINISH SYSTEM II: EXTERNAL INSULATION WITH PLASTER FINISH OVER POLYTHENE.</b></p> <p>5.2.1 The insulation shall be covered with 500 g polythene/polythene bonded Hessians (PBH) with 50mm overlap on longitudinal &amp; circumferential joints. Overlaps shall be sealed with synthetic adhesive in case o-f polythene &amp; liberal coat of bitumen in case of PBH:</p> <p>5.2.2 The surface shall then be wrapped with 20mm (3/4") mesh of 24 SWG GI wire butting all the joints &amp; laced down with 22 SWG GI lacing wire.</p> <p>5.2.3 12.5mm thick (1/2 inch) sand cement plaster in ratio of(4:1) shall be applied in two layers, the second layer being brought to a smooth &amp; even finish similarly as described above.</p> <p><b>5.3 FINISH III:EXTERNAL INSULATION WITH SHEET METAL FINISH</b></p> <p>5.3.1 The insulation shall be covered with 500g polythene with 50mm overlaps at joints which shall be sealed with synthetic adhesive or equivalent compound.</p> <p>5.3.2 The polythene shall be covered with 24 gauge GI/aluminum sheet</p> <p>5.3.3 25mm wide x 22 SWG GI/aluminum peripheral straps shall be fixed over the GI/aluminum sheet at 300mm centres to secure.</p> <p><b>5.4 FINISH IV: EXTERNAL INSULATION WITH PLASTER &amp; WATER PROOFING COMPOUND</b></p> <p>For ducts &amp; piping exposed to atmosphere, the finish shall be as follows:</p> <p>5.4.1 A thick vapor seal of hot bitumen at 2.05 kg/sq.m shall be applied on the outer surface of insulation &amp; allowed to dry.</p> <p>5.4.2 The surface shall then be wrapped with 20mm (3/4") hexagonal mesh of 24 SWG GI Wire butting all the joints &amp; laced down with 22 SWG GI lacing wire.</p> <p>5.4.3 12.5mm thick (1/*2 inch) sand cement plaster in ratio of (4:1) shall be applied in two layers, the second layer being brought to a smooth finish with water proofing compound added to the cement.</p>		

	<b>TECHNICAL SPECIFICATION</b>  <b>THERMAL INSULATION FOR COLD SURFACES</b>	<b>SPECIFICATION NO.PES-553-08</b>	
		<b>VOLUME II B</b>	
		<b>SECTION D</b>	
		<b>REV. 02</b>	<b>DATE: 17.09.2012</b>
		<b>SHEET 4 OF 6</b>	
5.4.4	<p>3 mm (1/8") thick coat of water proofing compound shall be applied &amp; wrapped with fibre glass RP tissue. A final coat of 3mm thick water RP proofing compound shall then be applied over the fiberglass RP tissue &amp; allowed to dry. Alternatively, in place of water proofing as desired above, tar felt type 3 grade 1 of IS 1322 with joints overlapped by 75mm shall be fixed &amp; sealed with bitumen &amp; over this 24 SWG. 25mm hexagonal GI mesh shall be fixed with 22 swig. GI lacing wire &amp; finally bitumen paint shall be applied over wire netting.</p>		

	<b>TECHNICAL SPECIFICATION</b>  <b>THERMAL INSULATION FOR COLD SURFACES</b>	<b>SPECIFICATION NO.PES-553-08</b>	
		<b>VOLUME II B</b>	
		<b>SECTION D</b>	
		<b>REV. 02</b>	<b>DATE: 17.09.2012</b>
		<b>SHEET 5 OF 6</b>	
<p><b>6. <u>INSULATION OF PUMPS &amp; VALVES</u></b></p> <p>6.1 For all inspection covers &amp; hatches on equipment, pump casing &amp; valve bodies, flanges etc. the insulation shall be applied such as to facilitate removal with minimum damage to the insulation. This shall be achieved by encasing the insulation in 22 gauge aluminum sheet metal boxes, which shall be bolted together around the equipment to permit easy removal &amp; replacement. Proper care shall be taken to maintain continuity of vapor seal between the static &amp; removable partitions of the insulation.</p> <p>6.2 The tenderer may offer thickness of insulation &amp; finishes other than that specified in DATA SHEET A. However, calculations/reasons in support of alternative proposal shall be furnished for purchaser's approval.</p> <p><b>7. <u>INSPECTION &amp; TESTING (REFER SPEC. NO - PES-553.00)</u></b></p> <p>7.1 All necessary tests, as required to ensure that the material supplied conform to the requirements of applicable codes &amp; standards, shall be carried out at manufacturer's works &amp; test certificates including these for material/accessories shall be furnished for purchasers approval.</p> <p><b>8. <u>PAINING</u></b></p> <p>8.1 Pipe work having insulation &amp; cladding shall be provided with color identification for the fluids handled and for indicating direction of flow.</p> <p>8.2 Equipment surfaces having insulation and cladding shall also have identification numbers and any other relevant data provided on the insulated surface.</p> <p>8.3 All painting for insulated surfaces shall conform to the requirement specified elsewhere.</p>			

	<b>TECHNICAL SPECIFICATION</b>  <b>THERMAL INSULATION FOR COLD SURFACES</b>	<b>SPECIFICATION NO.PES-553-08</b>	
		<b>VOLUME II B</b>	
		<b>SECTION D</b>	
		<b>REV. 02</b>	<b>DATE: 17.09.2012</b>
		<b>SHEET 6 OF 6</b>	

**9. DATA TO BE FURNISHED AFTER AWARD OF CONTRACT**

- 9.1 Final version of data sheet 'B' incorporating changes if any along with design data.
- 9.2 Test certificates/reports giving result of insulation to ensure conformance to applicable codes & standards & in particular the following:-
- a) Thermal conductivity test.
  - b) Sound absorption coefficient test.
  - c) Corrosion test.
  - d) Sulphur content, moisture content, shot content, moisture absorption etc.
  - e) Compressive strength & cross breaking strength test.
- 9.3 Sketches/technical literature/sectional drgs. indicating insulation materials finish and method of application etc.
- 9.4 Manual dealing with safety aspects & instructions for combating fire arising out of insulation work.
- 9.5 Instructions on maintenance of insulation work.





**THERMAL INSULATION**  
**FOR COLD SURFACE**  
**DATA SHEET - A**

VOLUME II-B

SECTION D

REV 00

DATE 17.09.2012

SHEET 1 OF 1

**Insulation Material**

Insulation	Code	Thermal Conductivity MW/cm <sup>0</sup> C	Density Kg/m <sup>3</sup>
Resin bonded mineral wool / glass wool	IS:8183	0.49 at 50 <sup>0</sup> C	At least 24 for duct insulation and 48 for acoustic lining.
Mineral Wool Pipe Section (min. Gr.2)	IS:9842	0.43 at 50 <sup>0</sup> C	At least 81
Expanded Polystyrene	IS:4671	0.37 at 10 <sup>0</sup> C	At least 15

**Type of Insulation**

S.No.	Surface	Insulation Material	Insulation Form	Thickness (mm)
i)	Supply & Return air duct for air-conditioning system	Resin bonded roll Mineral Wool (IS:8183)		25
ii)	Refrigerant Piping	a) Expanded Polystyrene	Pipe Section	75
		or		
		b) Mineral Wool	Pipe Section	75
iii)	AHU drain pipe	a) Expanded Polystyrene	Pipe Section	25
		or		
		b) Mineral Wool	Pipe Section	25
iv)	AHU drain pan coil section and fan section	a) Expanded Polystyrene	Slabs	25
		or		
		b) Mineral Wool	Slabs	25
v)	Chilled water piping, valves & specialties	a) Expanded Polystyrene	Pipe Section	75
		or		
		b) Mineral Wool	Pipe Section	75
vi)	Chiller	a) Expanded Polystyrene	Slabs	100
		or		
		b) Mineral Wool	Slabs	100
vii)	Chilled Water Pumps	a) Expanded Polystyrene	Slabs	50
		or		
		b) Mineral Wool	Slabs	50
viii)	Expansion tank with pipe	a) Expanded Polystyrene	Slabs/Pipe Section	50
		or		
		b) Mineral Wool	Slabs/Pipe Section	50



**STANDARD TECHNICAL SPECIFICATION  
FOR  
UAF**

**SPECIFICATION NO.PES-554-01**

**VOLUME II B**

**SECTION D**

**REV. 00**

**DATE: NOV 2012**

**SHEET 1 OF 3**

**STANDARD TECHNICAL SPECIFICATION  
FOR  
UAF**

	<b>STANDARD TECHNICAL SPECIFICATION FOR UAF</b>	SPECIFICATION NO.PES-554-01	
		VOLUME II B	
		SECTION D	
		REV. 00	DATE: NOV 2012
		SHEET 2 OF 3	
<b>1.</b>	<b>GENERAL</b>		
1.1.1	This specification covers the design, manufacture, construction features, installation, commissioning and conducting performance test at site.		
<b>2.</b>	<b>CODES AND STANDARDS</b>		
	The design/manufacture and performance of air washer shall comply with all currently applicable statutes, regulations and safety codes in the locality where the air washer is installed. The equipments shall also conform to the requirements of the latest editions of applicable Indian/British/US standards. Nothing in this specification shall be construed to relieve the vendor of this responsibility. In particular the equipments shall conform to the latest editions of the following standards:-		
2.1.1	IS:277: Galvanised steel sheets		
2.1.2	IS:1239: Mild steel tubes		
2.1.3	IS: 2062:		
<b>3.</b>	<b>DESIGN/CONSTRUCTION FEATURES</b>		
<b>3.1</b>	<b>GENERAL</b>		
3.1.1	The air washer shall be designed for max. air velocity of 2.8M/sec. Circulating water quantity shall be 1.0 CMH for every 1000 CMH of air flow, unless otherwise stated in data sheet A. The minimum saturating efficiency of air washer shall not be less than 90% Minimum length of air washer shall be 2500 mm.		
<b>3.2</b>	<b>TANK (SUMP)</b>		
3.2.1	The air washer tank shall either be masonry or metallic construction as specified in data sheet A. Masonry tank shall be provided by purchaser whereas metallic tank shall be of welded construction, fabricated from not less than 6mm thick MS plates, and inside, outside surfaces shall be provided with anti corrosive paint (Zinc sprayed to coating thickness of 75 micron min.).		
3.2.2	The air washer tank shall have a minimum depth of 600mm and tank construction shall be such that the suction screen can be replaced while the air washer is under operation. The inlet and outlet ends of tank shall be suitably constructed to accommodate distribution plates and eliminator plates.		
<b>3.3</b>	<b>DISTRIBUTION PLATE</b>		
3.3.1	The distribution plate shall be fabricated from minimum 18 gauge thick GSS and shall have minimum 50% free area. The angles used for supports shall be galvanised.		
3.3.2	The distribution plate shall be built up of number of sections for easy handling.		
<b>3.4</b>	<b>HEADERS AND STAND PIPE</b>		
3.4.1	The air washer shall be of two bank construction (one cross flow and other unit flow). The piping up to and including 100mm dia meter shall be of galvanised steel and above 100mm dia shall be black steel (subsequently spray galvanized to coating thickness as per approved TDS). All piping shall be adequately supported.		

	<b>STANDARD TECHNICAL SPECIFICATION FOR UAF</b>	SPECIFICATION NO.PES-554-01	
		VOLUME II B	
		SECTION D	
		REV. 00	DATE: NOV 2012
SHEET 3 OF 3			
<b>3.5</b>	<b>SPRAY NOZZLES</b>		
3.5.1	Spray nozzles shall be made of HDP (High density polyethylene) and shall be self cleaning type. The nozzles shall be designed to produce fine atomised spray and shall be spaced to give, uniform coverage of the air washer section. The pressure drop through the nozzle shall be in the range of 1.4 kg/cm <sup>2</sup> g to 2.4 Kg/cm <sup>2</sup> g		
<b>3.6</b>	<b>ELIMINATOR PLATE</b>		
3.6.1	Eliminator plate shall be fabricated from 22 gauge thick GSS (Zinc coating thickness as per approved TDS).The eliminator section shall have minimum 6 bends. Spacer bars, tie rods and supports shall be of galvanised steel construction. Eliminator box shall be complete with suitable drop tray and drain pipe.		
<b>3.7</b>	<b>SUCTION SCREENS</b>		
3.7.1	Suitable no. of suction screens shall be provided by vendor and one set of spare screens shall be furnished along with each air washer.		
<b>3.8</b>	<b>INSPECTION DOOR AND MARINE LIGHT</b>		
3.8.1	Air tight inspection door of 600x700mm, metallic construction shall be provided. The air washer shall be equipped with marine light as required.		
<b>3.9</b>	<b>MAKE UP, DRAIN AND QUICK FILL CONNECTION</b>		
3.9.1	The air washer shall be provided with quick fill and make up connection. The quick fill valve shall be a globe valve. Float valve for making connection shall be backed up by a gate valve. Drain connections complete with isolating valves shall be provided for both suction and main tank. Over-flow pipe shall be provided for main tank and shall be connected to drain pipe, before the isolating valve or drain. In case of masonry tanks suitable pipe pieces with stiffener plates shall be provided by Vendor for use during casting of masonry tank.		
<b>4.</b>	<b>DATA TO BE FURNISHED BY VENDOR AFTER AWARD OF CONTRACT</b>		
4.1.1	Performance curve for air washer		
4.1.2	GA drg.		
4.1.3	Foundation drag. weight, dynamic loading etc.		
4.1.4	O&M manual		



**UAF**  
**DATA SHEET - A**

VOLUME II-B

SECTION D

REV 00

DATE NOV 2012

SHEET 1 OF 2

S.No.	DESCRIPTION <u>GENERAL</u>	DETAILS
1.	Designation	Air washers for power house building.
2.	Nos. required	Refer Section-C of Specific Technical Requirement
3.	Service	Evaporative Cooling of TG Hall & electrical bay
4.	Location	As per section-C/ Tender Layout Drg.
<b>DESIGN DATA</b>		
5.	Type	Sheet metal type, as per schedule of Ventilation system.
6.	Capacity M3/hr	Refer Section-C of Specific Technical Requirement
7.	Inlet air temperature	(Refer design data.)
8.	Saturation Efficiency (min).	To achieve saturation efficiency of 90%
9.	Allowable Pressure drop through Spray nozzle	2.4 Kg/cm <sup>2</sup> (g) max.
9.	Pressure drop across Spray chamber	15 to 20 mm WG.
<b>MATERIALS</b>		
11.	Moisture Eliminators plates	24 SWG Galvanized Sheet (Vertical and brake type)./ 100% Virgin PVC of minimum finished thickness of 2 mm.
12.	Moisture Eliminators Frame	22 SWG G.I. Sheets.
13.	Distribution plates	18 G GSS to have 50% free area.
14.	Tank	MS
15.	Casing	Black M.S. (10 SWG min.)
16.	Louvers	20 G GSS sheet & frame of 18 G galvanized steel angle. Louvers with Bird screen of galvanized wire mesh of 10 mm square.
17.	Piping	MS Heavy Class Galvanized to IS: 1239 Part I, OR IS –3589 depending upon size.



**UAF**  
**DATA SHEET - A**

VOLUME II-B

SECTION D

REV 00

DATE NOV 2012

SHEET 2 OF 2

- |     |                      |  |
|-----|----------------------|--|
| 18. | Suction Screen Water | Brass (40 mesh size 2 nos for each air washer)   |
| 19. | Spray nozzles        | Brass/Bronze with chrome plating or suitable plastic material (Nylon/Polymer) and shall be self cleaning type. |
| 20. | Flooding Nozzles     | Nylon/Polymer.   |
| 21. | Banks                | Two spray banks each connected to individual header  |

**EQUIPMENT SELECTION CRITERIA**

- |     |  |                                    |
|-----|--|------------------------------------|
| 22. | Face Velocity through louver.                | Not to exceed 2.5 m/s              |
| 23. | Max. Pressure drop                           | Not to exceed 6.5 mm Wg when clean |
| 24. | Saturation efficiency                        | Not less than 90%.                 |
| 25. | Face velocity of air through spray chamber.  | Not to exceed 2.5 m/s.             |
| 26. | Allowable pressure drop for washing chamber. | 15 to 20 mm Wg.                    |

**NOTE:**

- 1) All parts coming in contact with moisture for air washer shall be spray galvanized/epoxy painted  
(2 coat of rust preventing epoxy primer & 2 coat of finished paint from both sides.)
- 2) Moisture eliminator shall have bends at 30 Degree with the direction of air flow & shall have effectively hooked edges for trapping the water.



**STANDARD TECHNICAL SPECIFICATION  
FOR  
VENTILATION FANS**

**SPECIFICATION NO.PES-554-03**

**VOLUME II B**

**SECTION D**

**REV. 02**

**DATE: NOV 2012**

**SHEET 1 OF 4**

**STANDARD TECHNICAL SPECIFICATION  
FOR  
VENTILATION FANS**

	<b>STANDARD TECHNICAL SPECIFICATION FOR VENTILATION FANS</b>	SPECIFICATION NO.PES-554-03	
		VOLUME II B	
		SECTION D	
		REV. 02	DATE: NOV 2012
		SHEET 2 OF 4	
1.	<b>GENERAL</b>  This specification covers the design, manufacture, testing of performance at manufacturer's/sub-contractors works, delivery at site, handling at site, erection and commissioning of ventilation fans.		
2.	<b>CODE AND STANDARDS</b>  The design, manufacture and performance of equipment shall comply with all currently applicable statutes, regulations and safety codes in the locality where it is to be installed. The equipment shall conform to latest edition of applicable Indian Standards or their equivalent standards. Nothing in this specification shall be construed to relieve the vendor of this responsibility. In particular the equipment shall conform to the latest editions of the Following standards.		
2.1.1	IS:4894	-Centrifugal fans	
2.1.2	IS:3588	-Electric Axial Flow fans	
2.1.3	IS:2312	-Propeller type A.C. ventilation fans	
2.1.4	IS-3963	-Roof extractor units	
2.1.5	BS:848	-Method of performance test for fans.	
2.1.6	AMCA publication 99 standards handbook		
2.1.7	AMCA standard 210, Test code for air moving devices.		
3.	<b>DESIGN AND CONSTRUCTION</b>		
3.1	<b>THE ENCLOSED DATA SHEET A GIVES THE NECESSARY DETAILS FOR CENTRIFUGAL/AXIAL/ROOF EXTRACTOR UNITS ETC.</b>		
3.2	<b>WELDING PROCESS AND WELDERS EMPLOYED FOR FABRICATION SHALL BE QUALIFIED AS PER ASME SEC. IX</b>		
3.3	<b>CASING</b>		
3.3.1	The centrifugal fans casing shall be of welded construction fabricated with heavy gauge material (min 3 mm) with flanges (min. 5 mm) on inlet and out let side for direct connection and shall be rigidly reinforced and supported by structural angles. The seams shall be permanently sealed airtight. Horizontal Split casings shall be provided on large size fans. Casing drain (at bottom) with threaded plug/ with valve shall be provided, as required. All mounting/ connecting holes shall be drilled off centre.		
3.3.2	The axial flow casing for supply fans/roof extractors shall be of heavy gauge construction (min 3 mm) properly reinforced for rigidity and shall be complete with suitable supports. Access doors with suitable locking arrangement shall be provided in the casing for easy access to the motor and impeller. External junction box/ Terminal box on casing with IP-55 protection shall be provided, if required. Wiring for motor from external junction box/ Terminal box shall be through flexible conduit.		
3.3.3	Suitable motor brackets designed for rigid mounting of motors, shall be provided for roof extractors and wall mounted exhaust/ supply fans.		



	<b>STANDARD TECHNICAL SPECIFICATION FOR VENTILATION FANS</b>	SPECIFICATION NO.PES-554-03	
		VOLUME II B	
		SECTION D	
		REV. 02	DATE: NOV 2012
		SHEET 3 OF 4	
<b>3.4</b>	<b>IMPELLER</b>		
3.4.1	Centrifugal fan impeller shall have die formed, aerofoil or laminar blades welded to the rim and back plate and shall have non-overloading, self cleaning characteristics. Rim shall be spun to have smooth contour. If required, intermediate stiffening rings shall be provided. Shaft sleeves shall be furnished, if specified. The impeller, pulley and shaft sleeve shall be secured to the shaft by key and/or nuts (threaded opposite to direction of rotation of impeller). The impeller shall be statically and dynamically balanced.		
3.4.2	The axial fan impeller shall be of high efficiency aerofoil design. The blades shall be mounted on a streamlined hub and the impeller shall be mounted directly on the motor shaft. Impeller shall be in one piece however; fabricated blades will be acceptable up to 450 mm impeller diameter.		
3.4.3	Roof ventilator impeller may either be centrifugal or axial type. Backward inclined blades shall be provided for centrifugal impellers. Blades may be die-formed or cast. Axial flow impeller shall be directly mounted to motor shaft whereas centrifugal impeller may either be direct-driven or belt-driven. The shaft of belt-driven centrifugal fan shall be solid cold rolled carbon steel, ground and polished. However, direct mounted impellers are preferred.		
<b>3.5</b>	<b>BEARINGS:</b>		
3.5.1	The centrifugal fan bearing may be ball, roller or sleeve bearings of self-aligning heavy duty type with adequate capacity and life. Make of Bearings to be specified. Bearings shall be oil/grease lubricated and provided with fittings for lubrication from outside and shall be located in easily accessible position to facilitate maintenance.		
<b>3.6</b>	<b>INLET CONES AND GUARDS</b>		
3.6.1	Centrifugal fans inlet shall be spun to have a smooth contour. Inlet screen, if provided, shall be galvanised wire mesh of 25 mm square with wire thickness of min. 1.5 mm.		
3.6.2	Inlet cone, outlet bell and suitably designed guards shall be provided.		
<b>3.7</b>	<b>GUIDE VANES:</b>		
3.7.1	In case of vane axial fans guide vanes shall be provided on discharge side.		
<b>3.8</b>	<b>BASE PLATE AND VIBRATION ISOLATORS</b>		
3.8.1	Base plate and vibration isolators, which may be double deflection rubber in shear or rubber in compression type or spring type shall be provided. With each fan rubber bushes, washers wherever needed for vibration isolator in sufficient nos. shall be included, as required, to ensure isolation of foundation from vibration of equipment. For roof ventilators suitable mounting arrangement shall be provided such that there is no ingress of rain water into the building.		
<b>3.9</b>	<b>HOOD AND COWL</b>		
3.9.1	Roof exhaustors shall be provided with hinge type hood providing easy access to motor and impeller. Weather proof lockable type disconnect switch shall be provided such that hood can open only when the disconnect switch is in 'off'		

	<b>STANDARD TECHNICAL SPECIFICATION FOR VENTILATION FANS</b>	SPECIFICATION NO.PES-554-03	
		VOLUME II B	
		SECTION D	
		REV. 02	DATE: NOV 2012
		SHEET 4 OF 4	
<p>position. On larger size of roof ventilators hoods may be of split construction. 15 mm mesh galvanised bird screen shall be provided.</p> <p>3.9.2 Rain protection cowls shall be designed to suit wall exhausters/supply fans for protecting fans from rain. The cowls shall be provided with bird screen of heavy gauge expanded metal netting.</p> <p><b>3.10 SPEED</b></p> <p>3.10.1 The speed of axial flow fans/roof ventilators shall not exceed 960 RPM for impeller dia exceeding 450 mm and shall not be greater than 1440 with impeller dia less than 450 mm.</p> <p><b>4. MOTORS</b></p> <p>Drive motors shall be of totally enclosed type, suitable for horizontal/vertical mounting as applicable and shall comply with the requirements of the specifications furnished elsewhere for motors.</p> <p><b>5. ACCESSORIES</b></p> <p>Accessories as specified in Data sheet-A and as required for satisfactory trouble free &amp; safe operation of fans shall be provided.</p> <p><b>TESTING AND INSPECTION</b></p> <p>List of TCs arranged as per Approved Quality Plan shall be furnished along with copy of TCs at the time of inspection by BHEL</p> <ul style="list-style-type: none"> <li>➤ Visual inspection of sheets/plates, angles, channels etc. – Pitting, lamination in sheets/ plates, angles and channels shall be avoided.- visual inspection by main contractor of BHEL.</li> <li>➤ Sheets/ Plates - Test certificate shall be furnished for physical and chemical properties for sheets / plates- for review by BHEL</li> <li>➤ Shaft: Mechanical and chemical— review by BHEL</li> <li>➤ Motors (of approved make): Routine TC ,FLP TC if applicable</li> <li>➤ Workmanship and dimensional check as per manufacturing drg. and approved Drgs.- by main contractor of BHEL.- Shall be checked by BHEL/ Customer during final inspection.</li> <li>➤ Balancing of impellers- Dynamic balancing certificates shall be furnished –grade 6.3 or better to ISO-1940. Balancing weights shall be positively locked/ welded to avoid loosening. - witness by manufacturer - TC to be furnished for review by BHEL(consisting of weight of impeller, radius of correction and balancing rpm). For spare impellers Dynamic Balancing shall be witnessed by BHEL.</li> <li>➤ Performance test of one Centrifugal fan or Axial Fan /per type/per size as per applicable standard – by BHEL.</li> </ul> <p>Centrifugal/ Axial fans 100% run tested by main contractor of BHEL. Run test by BHEL/Customer may be at random or 100%- Vibration shall be within satisfactory zone of VDI 2056 (group- G ) machines when measured on bearing housing and noise level &lt;85 dbA at 1 metre distance. Max. Temp. on bearing housing- 40 degrees Centigrade + ambient</p>			



**CENTRIFUGAL FAN**  
**DATA SHEET - A**

VOLUME II-B

SECTION D

REV 00

DATE NOV 2012

SHEET 1 OF 3

<u>No.</u>	<u>Particulars</u>	<u>Data</u>
1	<b><u>General Information</u></b>	
1.1	Fan Designation/application. system/	Refer schedule of Ventilation Air washers & UAF Units.
1.2	Nos. required/capacity Technical	Refer Section-C of Specific Requirement
1.3	Location	Refer layout drg. Attached.
2.0	<b><u>Design Data</u></b>	
2.1	Type	DIDW for Air Washer and SISW for UAF
2.2	Type of blades	backward curved
2.3	Arrangement	To suit application as per layout.
2.4	Discharge direction	To suit application as per layout.
2.5	Duty	Continuous
2.6	Capacity at site (Cubic Meter/hr) & static pressure. Technical	Refer Section-C of Specific Requirement
2.7	Suction pressure (mm Wg)	As per system requirement.
2.8	Fluid	Atmospheric Air.
2.9	Suction Temperature	Refer weather data attached.
2.10	Suction humidity	Refer weather data attached.
3.0	<b><u>Materials</u></b>	
3.1	Fan Scroll	Heavy Gauge Mild Steet to IS: 2062 with galvanised
3.2	Fan Casing (side plates & stiffeners)	Heavy Gauge Mild Steet to IS: 2062 / IS: 1079 / Eq. Minimum 3 mm thick casing.
3.3	Impeller	Mild Steel/plate to IS: 2062
3.4	Impeller hub	Mild Steet/plate to IS: 2062
3.5	Impeller back plate blade & shroud	Mild Steet to IS: 2062 / IS: 1079 / Eq.



## CENTRIFUGAL FAN

DATA SHEET - A

VOLUME II-B

SECTION D

REV 00

DATE NOV 2012

SHEET 2 OF 3

3.6	a) Shaft b) Shaft sleeve	EN-8 or eqv. -do-
3.7	Support frame and structure.	Mild Steel to IS: 2062
3.8	Flexible connection at outlet impregnated canvas with MS Flanges and cleats (3mm thick).	Fire resistant type plastic
3.9	V Belt	ISI marked (Reinforced rubber section to IS: 4776)
3.10	V Pulley per	Cast Iron multi groove to grade FG 20 as
3.11	Slide rails	IS: 210. Having taper lock type M.S./C.I.
3.12	Connection pieces	G.I. according to supplier's design
3.13	Bolts & nuts	M.S. Galvanized / Epoxy painted.
3.14	Vibration isolating pads, washers and spring if any.	Hard synthetic rubber
4.0	<b><u>ACCESSORIES</u></b>	
4.1	Common base plate	Required.
4.2	Anchor bolts	-do-
4.3	Vibration Isolators	Hard synthetic rubber
4.4	V-belt pulleys	-do-
4.5	V-belts	Reinforced rubber of appropriate section
4.6	Belt guard	Required.
4.7	Outlet damper	Required(M.S. Heavy Gauge)
4.8	Inlet guard	Required.
4.9	Inlet Vane (variable)	Not required.
4.10	Drain valve	Required.
4.11	Acoustic silencers	Not required.
5.0	<b><u>Motor</u></b>	
5.1	Motor by	Bidder



**CENTRIFUGAL FAN**  
**DATA SHEET - A**

<b>VOLUME II-B</b>	
<b>SECTION D</b>	
<b>REV 00</b>	<b>DATE NOV 2012</b>
<b>SHEET 3 OF 3</b>	

5.2 Starter by

BHEL

6.0 Painting of fans including base frame

Galvanized / epoxy painting (as per Section-C & painting specifications)

**NOTE:**

- 1) Motors shall have 15 % margin on duty power point.
- 2) Fan shall be designed to operate with in 9% and 25% of system throttling line.
- 3) Opposed Multiple louvers damper shall be provided at fan outlet. Louvres shall be of 2 mm thick MS (galvanized). Casing shall be of 3.15 mm thick MS (galvanized).



**VENTILATION FAN (R.E.UNIT)**

**DATA SHEET - A**

VOLUME II-B

SECTION D

REV 00

DATE : NOV 2012

SHEET 1 OF 2

**General Information**

- |    |               |   |
|----|---------------|---|
| 1) | Designation   | Roof extractor Units for areas as per schedule of ventilation system. |
| 2) | Nos. required | As per schedule.  |
| 3) | Service       | Continuous  |
| 4) | Location      | Roof of respective areas.   |
| 5) | Area          | As per schedule   |

**Design Data**

- |     |                               |  |
|-----|-------------------------------|--|
| 6)  | Type                          | axial flow type.                                   |
| 7)  | Air delivery capacity system. | as per schedule of ventilation                     |
| 8)  | Fluid                         | Atmospheric Air.                                   |
| 9)  | Temperature                   | 50 Deg. C  |
| 10) | Static Pressure required      | As per Section 'C' schedule of ventilation system. |
| 11) | Outlet air velocity           | Not more than 12 m/sec.                            |

**Materials**

- |     |  |   |
|-----|--|---|
| 12) | Casing/cowl/hood                       | M.S. Sheet to IS: 2062 /IS: 1079/Eq.          |
| 13) | Impeller<br>617                        | Cast Aluminium alloy to A-6M IS-<br>Grade LM6 |
| 14) | Support frame and structure.<br>2062). | M.S. of adequate thickness (IS-               |

**ACCESSORIES**

- |     |                          |      |
|-----|--------------------------|------|
| 15) | Vibration isolating pads | Yes. |
| 16) | Base frame for mounting  | Yes. |
| 17) | Wire Guard at inlet.     | Yes. |
| 18) | Disconnect switch        | Yes. |



## VENTILATION FAN (R.E.UNIT)

DATA SHEET - A

VOLUME II-B

SECTION D

REV 00

DATE : NOV 2012

SHEET 2 OF 2

19) Gravity damper at outlet

Yes

**Motor**

20) Motor by

Bidder

21) Starter by

Bidder

22) Type of motor

Conforming to IS: 325 latest/as per specification.

23) Free delivery test

Yes.

24) Performance test at specified duty point.

Yes

25) Speed

Not more than 1500 RPM

## NOTE:

1. Motors shall have 15% on duty power Point.



## Ventilation Fan (Axial Flow Type)

DATA SHEET - A

VOLUME II-B

SECTION D

REV 00

DATE NOVEMBER 2014

SHEET 1 OF 2

**No. Particulars****Data**General Information

- |                     |  |
|---------------------|--|
| 1) Designation      | Supply/Exhaust Fans.   |
| 2) Nos. required in | Refer schedule of Ventilation system section-C under specific technical requirement. |
| 3) Service air.     | To exhaust warm air/to supply fresh  |
| 4) Location         | Wall mounted.  |
| 5) Area             | Same as above in 2.  |

Design Data

- |                                  |  |
|----------------------------------|--|
| 6) Type supply                   | Axial fans suitable for 415V/3 phase for Motor.    |
| 7) Air delivery capacity system. | As per schedule of ventilation                     |
| 8) Fluid                         | Atmospheric Air.                                   |
| 9) Temperature                   | Refer Section of specific technical requirement    |
| 10) Static Pressure required     | As per Section 'C' schedule of ventilation system. |
| 11) Outlet Air Velocity          | Not more than 12 m/sec.                            |

Materials

- |   |   |
|---|---|
| 12) Casing                                    | M.S. (IS-2062)                                  |
| 13) Impeller 617)                             | Cast Aluminium. (Alloy A-6M, IS-                |
| 14) Hub                                       | Al Alloy.                                       |
| 15) Support frame and structure. (Galvanized/ | M.S. of adequate thickness<br>Painted) IS-2062. |
| 16) Neoprene rubber pads                      | As required.                                    |





### Ventilation Fan (Axial Flow Type)

#### DATA SHEET - A

VOLUME II-B

SECTION D

REV 00

DATE NOVEMBER 2014

SHEET 2 OF 2

- |     |   |  |
|-----|---|--|
| 17) | Coned inlet for wall exhausters/supply fans | MS (IS-2062)   |
| 18) | Supporting frame for mounting.              | Required.  |
| 19) | Protective screen at inlet.                 | Yes (Min 14 SWG Galvanized wire knitted in 1" square mesh. |
| 20) | Rain Protection Cowl                        | Aluminum or hot dip Galvanized after fabrication from M.S. |

#### Motor

- |     |            |        |
|-----|------------|--------|
| 21) | Motor by   | Bidder |
| 22) | Starter by | BHEL   |

#### NOTE:

- 1) For Battery Room, motor for fan shall be of flame proof type & fan of spark proof construction with Epoxy painting.
- 2) Gravity type damper shall be provided at the outlet of axial fan for exhaust application.
- 3) Motor shall have 15% margin over Duty Point.



**STANDARD TECHNICAL SPECIFICATION FOR  
CENTRIFUGAL PUMPS**

SPECIFICATION NO. PES-554-05

VOLUME II-B

SECTION D

REV 01

DATE NOV 2012

SHEET 1 OF 8

**STANDARD TECHNICAL SPECIFICATION  
FOR  
CENTRIFUGAL PUMPS**



**STANDARD TECHNICAL SPECIFICATION FOR  
CENTRIFUGAL PUMPS**

SPECIFICATION NO. PES-554-05

VOLUME II-B

SECTION D

REV 01

DATE NOV 2012

SHEET 2 OF 8

1.0 **GENERAL**

This specification covers the design, material, constructional features, manufacture, assembly, inspection and testing at manufacturer's or his subcontractor's works, suitable painting requirements of centrifugal pumps and drives complete with all accessories as specified hereinafter.

2.0 **CODES AND STANDARDS**

2.1 The design, manufacture, inspection, testing & performance of the pumps as specified hereinafter, shall comply with the requirements of the latest revision of the following standards as indicated below (as applicable):

- |    |                                      |   |
|----|--------------------------------------|---|
| a) | IS-1520                              | :Horizontal centrifugal pumps for clear, cold and fresh water |
| b) | IS-5120                              | :Technical requirements - Rotodynamic special purpose pump    |
| c) | IS-1710                              | :Vertical turbine pumps for clear, cold and fresh water       |
| d) | Hydraulic Institute Standards of USA |   |
| e) | BS - 599                             | :Method of testing Pumps                                      |
| f) | PTC - '6'                            | :Centrifugal Pumps Power test code                            |
| g) | API - 610                            |   |

Wherever standards for certain aspects materials etc., not mentioned, the same shall be as per the applicable Indian or International standards.

2.2 In case of any conflict between the above codes/standards and this specification, the later shall prevail and in case of any further conflict in this matter, the decision of Purchaser's engineer shall be final and binding.

3.0 **DESIGN REQUIREMENTS**

3.1 The pumps shall be of heavy duty suitable for long periods of uninterrupted service and shall be standard product of the manufacturer thoroughly proven for satisfactory performance and reliability

3.2 The materials of construction of various components shall be as indicated under Data Sheet-A and where not specified to the applicable Indian/British/American standards.

3.3 All pressure containing components including the pump casing, nozzles and stuffing box housing shall be designed, fabricated and tested in accordance with applicable Indian standards if not specified otherwise.

3.4 The pump shall be suitable for handling the fluid as specified in Data Sheet-A

4.0 **CONSTRUCTIONAL FEATURES**

4.1 **Pump Casing**

4.1.1 Pump casing may be axially or radially split or barrel type construction as specified in the pump data specification sheet. The casing shall be designed to withstand the maximum pressure developed by the pump at the pumping temperature.



**STANDARD TECHNICAL SPECIFICATION FOR  
CENTRIFUGAL PUMPS**

SPECIFICATION NO. PES-554-05

VOLUME II-B

SECTION D

REV 01

DATE NOV 2012

SHEET 3 OF 8

4.1.2 Pump casing shall be provided with adequate number of vent and priming connections with valves, unless the pump is made self venting & priming. Casing drain, as required, shall be provided complete with drain valves.

4.1.3 Pump shall preferably be of such construction that it is possible to service the internals of the pump without disturbing suction and discharge piping connections.

4.1.4 Under certain conditions, the pump casing nozzles will be subjected to reactions from external piping. Pump design must ensure that the nozzles are capable of withstanding external reactions not less than those specified in API-610.

4.2 **Impeller**

Unless specifically indicated under Data Sheet-A enclosed, the pump impellers shall be of closed vane type. The impellers shall be secured to the shaft and shall be retained against circumferential movement by keying, pinning or lock rings. Impellers shall be statically and dynamically balanced individually. The assembled rotor shall be dynamically balanced and checked for eccentricity.

4.3 **Wearing Ring**

Renewable wearing rings for the casing and/or the impellers and renewable shaft sleeves, shall be provided for all pumps. Length of the shaft sleeves must extend beyond the outer faces of gland packing or seal and plate so as to distinguish between the leakage between shaft & shaft sleeve and that past the seals/gland.

4.4 **Shaft**

Shaft size selected shall take into consideration the critical speed which shall be away from the operating speed as recommended in applicable Code/Standard. The critical speed shall also be at least 10% away from runaway speed.

4.5 **Bearings**

Bearings and hydraulic devices (if provided for balancing axial thrust) of adequate design shall be furnished for taking the entire pump load arising from all probable conditions of continuous operation throughout its Range of Operation and also at the shut off condition. The bearing shall be designed on the basis of 20,000 working hrs minimum for the load corresponding to the duty point. Proper lubricating arrangement for the bearings shall be provided. The design shall be such that the bearing-lubricating element does not contaminate the liquid being pumped. Where there is a possibility of liquid entering the bearing, suitable arrangement in the form of deflectors or otherwise shall be provided ahead of bearing assembly. Bearings shall be easily accessible without disturbing the pump assembly.

4.6 **Stuffing Boxes**

Packed type stuffing boxes of adequate depth with lantern rings shall be provided to minimize the leakage. In all cases where the pump suction is below atmospheric pressure, the shaft packing shall be sealed by the liquid pumped by tapping off from the pump discharge itself and all pipes, valves, fittings etc., required for this shall be furnished by the manufacturer.

4.7 **Shaft Couplings**



**STANDARD TECHNICAL SPECIFICATION FOR  
CENTRIFUGAL PUMPS**

SPECIFICATION NO. PES-554-05

VOLUME II-B

SECTION D

REV 01

DATE NOV 2012

SHEET 4 OF 8

The pumps shall be directly coupled to their drives through heavy duty flexible coupling. Suitable coupling guards shall be provided along with the coupling. The pump and its drive motor shall be mounted on a common base plate.

**4.8 Base Plate and sole Plate**

Unless otherwise stated the data specification sheet, a common base plate mounting both for the pump and drive shall be furnished. The base plate shall be of rigid construction, suitably ribbed and reinforced. Base plate and pump supports shall be so constructed and the pumping unit so mounted as to minimize misalignment caused by mechanical forces such as normal piping strain, hydraulic piping thrust, etc. Suitable drain taps and drip lip shall be provided.

If required in the data specification sheet, steel sole plates shall be provided, below the base plate.

**4.9 Prime Mover**

The drive motor selected shall conform to the requirements of the enclosed motor specifications.

**4.10 Lifting arrangement**

Each pump and motor shall incorporate suitable lifting attachments e.g. lifting lugs or eye bolts etc., to facilitate erection and maintenance.

**5.0 Performance Requirements**

5.1 The pump shall be designed to have best efficiency at the specified duty point. The pump set shall be suitable for continuous operation at any point within the Range of Operation as stipulated in the data specification sheets.

5.2 Pump shall have a continuously rising head capacity characteristics from the specified duty point towards shut off point, the maximum being at shut off. Power capacity characteristic will be non-overloading type i.e. 110% of the design flow the power required to drive the pump will be practically the same as that at the design flow.

5.3 Wherever specified in data sheet, pumps of each category shall be suitable for parallel operation. The head vs capacity, input power vs. capacity characteristics, etc., shall match to ensure equal load sharing and trouble free operation throughout the range.

5.4 The pump motor set shall be designed in such a way that there is no damage due to the reverse flow through the pump which may occur due to any malfunction of the system.

**6.0 Drive Rating**

6.1 The power rating of the drive shall be selected such that a minimum margin of 15% is available over the pump input power required at the rated duty point. However, the drive rating shall not be less than the maximum power requirement at any point within the 'Range of Operation' specified.



**STANDARD TECHNICAL SPECIFICATION FOR  
CENTRIFUGAL PUMPS**

SPECIFICATION NO. PES-554-05

VOLUME II-B

SECTION D

REV 01

DATE NOV 2012

SHEET 5 OF 8

6.2 In cases where parallel operation of the pumps are specified the actual drive rating is to be selected by the bidder considering overloading of the pumps in the event of tripping of one of the operating pumps.

6.3 The bidder under this specification shall assume full responsibility in the operation of the pump and the drive as one unit.

**7.0 SCOPE OF INSPECTION AND TESTING**

**7.1 Castings**

7.1.1 Witnessing pouring and thereafter physical testing of castings of 'Critical' nature such as casings, impellers, diffusers.

7.1.2 Identification and correlation with test reports for all tests as per the relevant material specifications for castings of 'Major' nature such as suction bell, discharge elbow, stuffing box, gland, wearing rings, shaft sleeves etc.

7.1.3 Foundry's conformity certificate for castings of 'Minor' nature such as base plates, covers etc.

7.1.4 Verification of neat treatment charts (as applicable)

Note: Casting effects shall not be filled by any method until an unless approved by BHEL/their customer

**7.2 Forgings and**

7.2.1 Identification and correlation with mill test certificates for all tests as per the relevant specifications for important forgings like casings, stage bodies, diffusers, shaft material.

7.2.2 Verification of neat treatment charts (time temperature) (as applicable).

**7.3 Fabricated items**

7.3.1 Identification and correlation with mill test certificates for material of items such as discharge bellows, column pipes etc.

7.3.2 Approval of welding procedure specifications and qualifications of weld procedures and personnel.

7.3.3 Dye penetrant tests of weldment as per ASTM E-165 and acceptance norm as per ASME Sec.VIII, Div.1, Appendix 8

7.3.4 Verification of heat treatment charts (time temperature), (as applicable)

7.3.5 Hydro test as per para 7.5.1 below.

Note: For para 7.1.2, 7.2.1 and 7.3.1 above; in case correlating test certificates are not available, material shall be identified by BHEL and physical tests conducted by the supplier in the presence of BHEL



**STANDARD TECHNICAL SPECIFICATION FOR  
CENTRIFUGAL PUMPS**

SPECIFICATION NO. PES-554-05

VOLUME II-B

SECTION D

REV 01

DATE NOV 2012

SHEET 6 OF 8

#### 7.4 In process Inspection and Testing

7.4.1 Dye penetrant testing after machining for impellers including vanes, pump shaft, diffusers as per applicable code; in absence of which, as per ASTM E - 165. No defect shall be permitted on moving parts. On static parts acceptance norms are as per ASME Sec.III NB 2546.

7.4.2 Ultrasonic testing of dynamic duty component, i.e. pump shafts (50mm dia and above) and static duty forgings i.e. Barrel, casting (15mm and above wall thickness) as per applicable code, in absence of which as per ASTM E388 and acceptance norms as stipulated hereunder.

7.4.3 Acceptance norms for UT for dynamic duty components. the following defects are unacceptable :

- a) Cracks, flakes, seams and laps
- b) Defects giving indications longer than that from a 4mm equivalent flaw.
- c) Group of defects with maximum indications less than that from a 4mm equivalent flaw, which cannot be separated at testing sensitivity, if the back echo is reduced to less than 50%.
- d) Defects giving indications of 2 to 4mm dia. equivalent flaw separated by distance less than four times the size of the larger of the adjacent flaw.

7.4.4 For static duty components - as per NB 2542.2 of ASME Sec. III.

7.4.5 Hydro tests of all pressure parts such as casings, column pipes, discharge elbows etc., at two times duty point pressure or 1.5 time shut off pressure, whichever is higher for 30 min., without any leakage.

Note : In case the pump is required to boost certain pressure, the inlet pressure head shall also be taken into consideration to compute test pressures.

7.4.6 Static and dynamic balancing of individual impellers and also assembled rotors as per V.D.I. 2060 Q 6.3 or ISO 1940 G 6.3.

#### 7.5 Performance Test

7.5.1 Pump testing with unit supply motor as per specifications and acceptance norms cited elsewhere, in absence of which as per IS 5120 latest edition. Performance shall be checked for minimum of 7 points (including shut off head and over load) following characteristics shall be checked:

Capacity V/s Head

Capacity V/s Power absorbed by pump

Capacity V/s pump efficiency

Note : For pump of fire protection system, performance test shall be conducted up to 150% of rated capacity

7.5.2 NPSH test in case specifically mentioned elsewhere



**STANDARD TECHNICAL SPECIFICATION FOR  
CENTRIFUGAL PUMPS**

SPECIFICATION NO. PES-554-05

VOLUME II-B

SECTION D

REV 01

DATE NOV 2012

SHEET 7 OF 8

- 7.5.3 Vibration and noise level measurement. Acceptance norms shall be as per manufacturers standards.
- 7.5.4 Overall dimensions as per GA drawings
- 7.5.5 Examination after selective opening up after running for pumps operating at speed over 1800 rpm and capacity exceeding 68M<sup>3</sup>/hr.
- 7.5.6 Painting and packing as per technical specification.

**7.6 Test at site**

The pumps will be tested at site by the purchaser to verify their performance. If the pumps fail to operate smoothly or within the required performance all such deficiencies shall be rectified by the manufacturer by making suitable alternatives in the pump set and additional tests required to show the effect of such alterations shall be performed by him.

**7.7 Performance Guarantee**

The vendor shall guarantee the material and workmanship of all components as well as the operation of the pump as per requirement of this specification.

The vendor shall also guarantee for each pump the total dynamic head at the specified rated capacity and also corresponding efficiency, brake horse power and shut off head.

**8.0 CLEANING, PROTECTION & PAINTING**

Before shipment of the equipment to be supplied under this specification the necessary cleaning, flushing etc., as per manufacturers standard shall be done to remove all dirts, scales etc. Shop coats of rust inhibiting paints, lacquers etc., shall be applied to various parts as necessary. Flanges, inlet and outlet pipe, etc shall be protected.

**9.0 DRAWINGS, TECHNICAL DOCUMENTS AND OTHER INFORMATION REQUIRED WITH THE PROPOSAL**

9.1 Fully dimensioned outline GA drawings of the pump motor assembly unit for each type and size offered. This drawing should include:-

- i) Foundation base plate and sole plate details as applicable
- ii) Civil foundation and anchor bolts details and loading data
- iii) Minimum submergence required for the pump (if applicable)

9.2 Cross sectional drawing of the equipment showing the details of assembly of components and their material of construction with standard applicable codes.

9.3 Performance characteristics (Discharge capacity vs head, BHP and efficiency of the pumps.





**STANDARD TECHNICAL SPECIFICATION FOR  
CENTRIFUGAL PUMPS**

SPECIFICATION NO. PES-554-05

VOLUME II-B

SECTION D

REV 01

DATE NOV 2012

SHEET 8 OF 8

- 9.4 Motor speed torque curve superimposed on pump speed torque curve. Required NPSH of pump.
- 9.5 Experience list about the supply and successful operation of similar pumps for similar application.
- 9.6 A comprehensive write up or brochure on the details of manufacturing and testing facilities in the shop of the manufacturer.
- 9.7 Quality plan for the equipment being offered, in BHEL format as practiced in the manufacturer's works and Field Quality Plan for receipt, storage erection, commissioning & testing at site.
- 9.8 Data sheet-B with all the particulars filled in.

**10.0 DRAWINGS AND DATA AFTER AWARD OF CONTRACT**

The vendor shall furnish the drawings and other technical documents as required in Data Sheet-C enclosed with this specification

**10.1 MANUFACTURERS NAME AND TAG. PLATES**

Each pump shall have a permanently attached brass/metal tag on the body indicating the following information both in Hindi and English.

- a) Manufacturer's name and trade mark
- b) Design Capacity and Head
- c) Design
- d) Purchaser's tag no. as furnished during the contract. The purchaser's tag no. will be indicated by the Purchaser on the drawing submitted for approval by the vendor.

**11.0 DRAWINGS/DOCUMENTS TO BE FURNISHED BY VENDOR AFTER THE AWARD OF CONTRACT.**

- 11.1 Certified GA drawings of pump motor assembly weights, crane
- 11.2 Detailed cross sectional drawings of the pump and motor assembly and all equipment & accessories supplied under the this specification along with details of material of construction with applicable standard codes
- 11.3 Foundation drawings with details of foundation pocket indicating static as well as dynamic load and other data with dimensions.
- 11.4 Certified characteristics curves (discharge capacity vs. head, BHP and efficiency) of each type of pump and motor.
- 11.5 Material and other test certificates as required by the application clauses of this specification.
- 11.6 Motor speed torque curves super imposed on pump speed torque curves.
- 11.7 Quality plan along with complete details of testing and inspection requirements of centrifugal pumps in BHEL format. Vendor shall also furnish Field Quality Plan.



**STANDARD TECHNICAL SPECIFICATION FOR  
CENTRIFUGAL PUMPS**

SPECIFICATION NO. PES-554-05

VOLUME II-B

SECTION D

REV 01

DATE NOV 2012

SHEET 9 OF 8

11.8 Installation , operation and maintenance manual.

11.9 Other drawings and data, if necessary.



**CENTRIFUGAL PUMPS**  
**DATA SHEET - A**

VOLUME II-B

SECTION D

REV 00

DATE NOV 2012

SHEET 1 OF 2

<u>S.No.</u>	<u>DESCRIPTION</u>	<u>DETAILS</u>
1)	Designation	Air washer Pumps.
2)	Type	Horizontal Centrifugal Type.
3)	Quantity	As per section-C
4)	Installation Washer	On floating type foundation inside Air Room
5)	Fluid to be handled	Filtered Water.
6)	Temperature of Fluid	To suit.
7)	Capacity Cum/Hr TDH at	To suit system requirements however head shall Not be less than 35 MWC.
8)	Duty	-----Continuous (24Hr./day)-----
9)	Suction condition	-----Flooded-----
10)	Type of drive	Direct (flexible coupling)
11)	Type of prime mover	LV Ac Motor.
12)	Maximum speed	Not more than 1500 RPM
13)	Type of lubrication	Grease Lubrication

**MATERIALS OF CONSTRUCTION**

<u>S.No.</u>	<u>DESCRIPTION</u>	<u>DETAILS</u>
a)	Impeller	Bronze
b)	Pump Shaft	Carbon Steel C-45, IS-1570 or class-IV, IS- 1875
c)	Casing	Cast Iron, grade-20, IS- 210
d)	Wearing ring	Bronze
e)	Shaft Sleeve	Bronze
f)	Base Plate/frame	Cast Iron to Grade FG-200 IS-210/fabricated Mild steel



**CENTRIFUGAL PUMPS**  
**DATA SHEET - A**

VOLUME II-B

SECTION D

REV 00

DATE NOV 2012

SHEET 2 OF 2

g)	Counter Flanges	Mild Steel
h)	Stuffing box bush	Deep Bronze packing to be renewable with Case.
i) not	Stuffing box gland	Flexible graphite or PTFE (Asbestos shall be used)
j)	Pump Motor Coupling	Pin & Bush type (Flexible)
k)	Bolt and Nuts	MS

15) **ACCESSORIES REQUIRED**

The following accessories shall be provided by the bidder for each pump.

a)	Priming funnel	Yes
b)	Drain piping upto Common drain point.	Yes
c)	Vent	Yes
d)	Suction & Discharge Pressure gauges	Yes
e)	Companion flanges	Yes
f)	Common base plate	Yes
g)	Suction strainer.	Yes
h)	Isolating valve.	Yes
i)	NRV at pump outlet at inlet/outlet	Yes
j)	Any special requirements	Yes
k)	Inspection & Testing	Yes



**AIR CONDITIONING SYSTEM**

**LIST OF MAKES OF SUB-VENDOR ITEMS**

**LIST OF MAKES OF SUB-VENDOR ITEMS**



## AIR CONDITIONING SYSTEM

## LIST OF MAKES OF SUB-VENDOR ITEMS

SLNo	ITEM	VENDOR
1	SCREW CHILLER	YORK
		TRANE
		CARRIER
		KIRLOSKAR
		DUNHAM BUSH
		MCQUAY (DAIKIN)
		BLUE STAR
		VOLTAS
2	CONDENSING UNIT	BLUE STAR
		CARRIER
		TRANE
		VOLTAS
3	PRECISION PACKAGE UNITS	STULZ
		UNIFLAIR
		EMERSON PROCESS MANAGEMENT (ROSEMOUNT)
		BLUEBOX
		CLIMADENTA
4	PACKAGE UNIT	VOLTAS
		BLUE STAR
		CARRIER
5	SPLIT AIR CONDITIONER	VOLTAS
		BLUE STAR
		CARRIER
		HITACHI-HIREL
		LG
6	AIR HANDLING UNITS	VOLTAS
		BLUE STAR
		ZECO
		CARRYAIRE (FLAKT)
		EDGETECH
		ETHOS
		SYSTEM AIR
		WAVES AIRCON
7	AHU FAN (CENTRIFUGAL FAN)	CB DOCTOR
		FLAKT
		KRUGER
		NICOTRA
		COMEFRI
		MARATHON
		PATEL AIR
		ADVANCE



## AIR CONDITIONING SYSTEM

## LIST OF MAKES OF SUB-VENDOR ITEMS

		DRAFT AIR
		HYDERABAD POLLUTION
		SK SYSTEM
		HOWDEN
		SARLA
8	LV MOTORS (NON FLAME PROOF)	SIEMENS
		ABB
		CGL
		MARATHON
		KEC
		BHARAT BIJLEE
		NGEF
		JYOTI
		LHP
		BHARAT ELECTRIC
9	AIR FILTER	PURULATOR
		FMI
		ANFILCO
		TENACITY
		JOHN FOWLER
		SPECTRUM
		AIR TECH
		PUROMATIC
10	FRESH AIR/ SUPPLY/ EXHAUST/ RE UNIT FANS	FLAKT
		KHAITAN
		PATEL AIR
		NICOTRA
		SARLA (SITAL)
		KRUGER
		MARATHON
		C B DOCTOR
		HYDERABAD POLLUTION
		SK SYSTEM
		HOWDEN
		ADVANCE
11	INSULTATION MATERIAL	BEARDSHEL
		K-FLEX
		PARAMONT
		ARMAFLEX
		SUPREME
		LLOYDS
		UP TWIGA



## AIR CONDITIONING SYSTEM

## LIST OF MAKES OF SUB-VENDOR ITEMS

		AEROCELL
12	BALANCING VALVE	ADVANCE
13	BUTTERFLY VALVES	ADVANCE
		AUDCO
		FOURESS ENGG
		INTER VALVE
		BDK
		WEIR BDK
		TYCO
		CRANE PROCESS
		KEYSTONE
		FLUIDLINE
		INSTRUMENTATION LTD
		R AND D MULTIPLES (METAL CAST) PVT LTD
		SURYA VALVES AND INSTRUMENTS MFG CO
		PENTAIR VALVES AND CONTROLS INDIA PRIVATE LIMITED
UPADHAYA VALVES MANUFACTURERS PRIVATE LIMITED		
VENUS PUMPS AND ENGG. WORKS		
14	NON RETURN VALVE	LEADER VALVES
		H SARKAR
		FLUIDLINE
		HI-TECH
		CRESCENT VALVES
		A V VALVES
		BANKIM
		SHIVADURGA
		SURYA VALVES AND INSTRUMENT MANUFACTURING
		ATAM VALVES
		GM DAULI & SONS
		KBL
VENUS PUMPS AND ENGINEERING WORKS		
15	4 WAY MIXING VALVE WITH ACTUATING MOTOR	SIEMENS BUILDING TECHNOLOGY
		JOHNSON
		BELIMO
		HONEYWELL AUTOMATION
		RAPID CONTROL
		ALC
16	BUTTERFLY VALVE (MOTORIZED)	ANERGY
		ADVANCE
		BELIMO





## AIR CONDITIONING SYSTEM

## LIST OF MAKES OF SUB-VENDOR ITEMS

		JOHNSON
		HONEYWELL AUTOMATION
		SIEMENS
		LEADER
		H.SARKAR
		FLUID LINE
		A V VALVES
		BANKIM & COMPANY
		SURYA VALVES AND INSTRUMENT MANUFACTURING
		ATAM VALVES
		GM DAULI & SONS
		KBL
		VENUS PUMPS AND ENGINEERING WORKS
17	ACTUATOR FOR MOTORIZED BUTTERFLY VALVE	SIEMENS BUILDING TECHNOLOGY
		JOHNSON
		BELIMO
		HONEYWELL
		RAPID CONTROL
		ALC
		AUMA
		LIMITORQUE
18	Y / POT STRAINER	MULTITEX
		GREAVES COTTON
		JAYPEE
		SANT VALVES
		OTOKLIN
		GRAND PRIX
		GUJARAT OTOLIFT
		DS ENGG
		SAROJINI ENTERPRISE
		BHATIA ENGINEERING
		FILTRATION ENGINEERS INDIA PVT LTD
		SUNGOV ENGINEERING
19	Pipes (MS/GI) - ERW	SURYA ROSHNI
20	Pipes (MS/GI) - ERW	TISCO
		DADU PIPES
		INDUS TUBES
		WELSPUN
		TATA
		BST
		JINDAL
		SAIL



## AIR CONDITIONING SYSTEM

### LIST OF MAKES OF SUB-VENDOR ITEMS

		PSL
		LALIT PROFILE
		SAMSHI PIPE INDUSTRIES
		S MUKUT PIPES
		MANN INDUSTRIES
		SURENDRA ENGINEERING
		PRATIBHA PIPES AND STRUCTURES PVT LTD
		JCO GAS PIPES
		NUKAT TANK AND VESSELS
		GOODLUCK TUBES
		ADVANCE STEEL TUBES
		BIHAR TUBES
		HITECH PIPES
		RATNAMANI
		MAHARASHTRA SEAMLESS
21	PIPING - CS SEAMLESS (ASTM A 106)	ISMT
		MAHARASHTRA SEAMLESS
22	GI SHEETS FOR DUCTING	TISCO
		INDIAN IRON & STEEL CO
		RASHTRIYA ISPAT NIGAM LIMITED
		ESSAR
		ISPAT INDUSTRIES
		JSW
		LLOYDS
		BHUSHAN STEELS
		TATA
		SAIL
		JINDAL
23	FIRE DAMPER	TSC
		CARRYAIRE
		RAVISTAR (SYSTEM AIR )
24	GRILL/DIFFUSER/VOLUME CONTROL DAMPER	AIR FLOW
		TSC
		AIR MASTER
		CARRYAIRE
		RAVISTAR (SYSTEM AIR )
25	STRIP HEATER	ESCORTS
		RACOLDS
		DASPASS
		ALCO
		HEATCO
		HOTSET



## AIR CONDITIONING SYSTEM

## LIST OF MAKES OF SUB-VENDOR ITEMS

26	PAN HUMIDIFIER	RAPID COOL
		HOTSET
		ALCO
27	RELIEF / PURGE VALVE	BRASSOMATIC
28	THERMOSTATS	HONEYWELL AUTOMATION
		RANCO
		PENN
		DANFOSS
		INDFOSS
		JHONSON CONTROL
		RANUTROL
29	HUMID STAT	JHONSON CONTROL
		HONEYWELL AUTOMATION
		PENN
30	ANTI FREEZE THERMOSTAT	RANCO
		HONEYWELL AUTOMATION
		PENN
		DANFOSS
		INDFOSS
31	FLOW SWITCH	SWITZER INSTRUMENT LTD.
		LEVCON
		DK INSTRUMENTS
		SBEM
		V AUTOMAT
		SIEMENS
32	SIGHT FLOW INDICATORS	SIGMA
		LEVCON
		V AUTOMAT
		TELLACE
		EUREKA INDUSTRIAL EQUIPMENTS PVT.LTD.
		TATA HONEYWELL
		BLISS ANAND
		SCIENTIFIC DEVICES
		BK EQUIPMENTS
		INSTRUMENTATION ENGINEERS
33	RH SENSOR/TEMP SENSOR	HONEYWELL AUTOMATION
		JOHNSON
		SIEMENS
		GENERAL INSTRUMENT CONSORTIUM
34	ANNUNCIATOR	ICC
		PECON



## AIR CONDITIONING SYSTEM

### LIST OF MAKES OF SUB-VENDOR ITEMS

		PROCON
35	LT ADAPTER BOX FOR AL TO CU CABLE CONVERTOR	CONTROL DEVICE
		SYSTEM POWER CONTROL
		JACKSON ENGINEERS
		UNILEC
		ELECTRIC ALLIED PRODUCT
36	WATER SOFTENING PLANT	THERMAX
		ION EXCHANGE
		DOSI ION
37	CHAIN PULLEY BLOCK	UNIVERSAL HOIST-O-FABRIK
		CENTURY CRANE ENGINEERS PVT. LTD.
		BAKELITE ELECTRICAL MFG. CO. PVT. LTD.
		TRACTEL TIRFOR INDIA PVT. LTD.
		BRADY & MORRIS ENGINEERING CO. LTD.
		TUOBRO FURGUSON (INDIA) PVT LTD
		TECHNO INDUSTRIES
38	ROTAMETER	CHEMTROLS SAMIL ( INDIA) PVT LTD.
		EUREKA INDUSTRIAL EQUIPMENTS PVT.LTD.
		IL
		TRANSDUCERS AND CONTROL

**NOTES:**

1. THE SUB VENDOR LIST ABOVE IS INDICATIVE ONLY AND IS SUBJECT TO BHEL AND CUSTOMER APPROVAL DURING DETAILED ENGINEERING STAGE WITHOUT ANY COMMERCIAL & DELIVERY IMPLICATION TO BHEL. BIDDER TO PROPOSE SUB VENDOR WITHIN 4 WEEKS OF PLACEMENT OF LOI. THEREAFTER NO REQUEST FOR ADDITIONAL SUB-VENDOR SHALL BE ENTERTAINED.
2. THE INSPECTION CATEGORY WILL BE INTIMATED AFTER AWARD OF CONTRACT BY BHEL/CUSTOMER. HOWEVER THE SAME WILL BE ADHERED BY THE BIDDER WITHOUT ANY COMMERCIAL AND DELIVERY IMPLICATION TO BHEL/ CUSTOMER.
3. PLEASE ALSO REFER RESPECTIVE SUB-SECTION C-3, C-4 & C-5 FOR ELECTRICAL, C&I AND HANDLING RELATED EQUIPMENT LIST OF MAKE.



**VENTILATION SYSTEM**

**LIST OF MAKES OF SUB-VENDOR ITEMS**

**LIST OF MAKES OF SUB-VENDOR ITEMS**



## VENTILATION SYSTEM

### LIST OF MAKES OF SUB-VENDOR ITEMS

SL No	ITEM	VENDOR
1	AIR WASHER & UAF*	HYDERABAD POLLUTION CONTROL
		SK SYSTEM
		ADVANCE VENTILATION
		DRAFT AIR
		BLUE STAR
		VOLTAS
		STERLING WILSON
		ROOTS COOLING SYSTEM
		C DOCTOR
		TAP
		PACK PLAST
2	CENTRIFUGAL FAN	INDUSTRIAL PROJECTS AND PRODUCTS
		FLAKT
		KRUGER
		DRAFT AIR
		HYDERABAD POLLUTION CONTROL
		ADVANCE VENTILATION
		PATEL AIR
		NICOTRA
		SK SYSTEM
		MARATHON
		CB DOCTOR
3	FRESH AIR/ SUPPLY/ EXHAUST/ RE UNIT FANS / PROPELLAR	SARLA
		COMEFRI
		HYDERABAD POLLUTION CONTROL
		SK SYSTEM
		ADVANCE VENTILATION
		KRUGER
		NICOTRA
		MARATHON
		FLAKT
		CB DOCTOR
		SARLA (SITAL)
PATEL AIR		
4	PUMPS	KHAITAN
		BEST & CROMPTON
		JYOTI
		SAM TURBO
		KBL
		KSB



## VENTILATION SYSTEM

### LIST OF MAKES OF SUB-VENDOR ITEMS

		M&P
		VOLTAS
		BEACON-WEIR
		WORTHINGTON
		FLOWMORE
		SULZER PUMPS INDIA LTD.
		BHARAT PUMPS & COMPRESSORS LTD
		FLOWSERVE INDIA CONTROL PVT LTD
		V-FLOW PUMPS & SYSTEMS CO
		KISHORE PUMPS
5	LV MOTORS (FLAME PROOF)	SIEMENS
		ABB
		CGL
		MARATHON
		KEC
		BHARAT BIJLEE
		BHARAT ELECTRIC
		NGEF
		JYOTI
		LHP
6	LV MOTORS (NON FLAME PROOF)	SIEMENS
		ABB
		CGL
		MARATHON
		KEC
		BHARAT BIJLEE
		BHARAT ELECTRIC
		NGEF
		JYOTI
		LHP
7	AIR FILTER	PUROLATOR
		FMI
		ANFILCO
		TENACITY
		JOHN FOWLER
		SPECTRUM
		AIR TECH
		PUROMATIC
8	INSULTATION MATERIAL	BEARDSHEL
		K-FLEX
		PARAMONT
		ARMAFLEX



## VENTILATION SYSTEM

### LIST OF MAKES OF SUB-VENDOR ITEMS

		SUPREME
		LLOYDS
		UP TWIGA
		AEROCELL
9	FIRE DAMPER	TSC
		CARRYAIRE
		RAVISTAR (SYSTEM AIR )
10	BUTTERFLY VALVES	AUDCO
		FOURESS ENGG
		INTER VALVE
		BDK
		WEIR BDK
		TYCO
		CRANE PROCESS
		KEYSTONE
		FLUIDLINE
		INSTRUMENTATION LTD
		R AND D MULTIPLES (METAL CAST) PVT LTD
		SURYA VALVES AND INSTRUMENTS MFG CO
		PENTAIR VALVES AND CONTROLS INDIA PRIVATE LIMITED
		UPADHAYA VALVES MANUFACTURERS PRIVATE LIMITED
		VENUS PUMPS AND ENGG. WORKS
11	NON RETURN VALVE	LEADER VALVES
		H SARKAR
		FLUIDLINE
		HI-TECH
		CRESCENT VALVES
		A V VALVES
		BANKIM
		SHIVADURGA
		SURYA VALVES AND INSTRUMENT MANUFACTURING
		ATAM VALVES
		GM DAULI & SONS
		KBL
		VENUS PUMPS AND ENGINEERING WORKS
12	STEEL GATE/GLOBE/NR VALVES(WATER SYSTEM)	CRESCENT VALVES
		BDK
		AUDCO
		FOURESS ENGG





## VENTILATION SYSTEM

### LIST OF MAKES OF SUB-VENDOR ITEMS

		KIRLOSKAR BROTHERS LTD.
		SANT VALVES
		BOMBAY METAL & ALLOYS
		BANKIM
		LEADER VALVES
		H SARKAR
		AV VALVES
		VENUS PUMPS
		FLUIDLINE
		HI -TECH
		SHIVADURGA
		SURYA VALVES AND INSTRUMENT MANUFACTURING
		ATAM VALVES
		GM DAULI & SONS
		KBL
13	Pipes (MS/GI) - ERW	SURYA ROSHNI
		TISCO
		DADU PIPES
		INDUS TUBES
		WELSPUN
		TATA
		BST
		JINDAL
		SAIL
		PSL
		LALIT PROFILE
		SAMSHI PIPE INDUSTRIES
		S MUKUT PIPES
		MANN INDUSTRIES
		SURENDRA ENGINEERING
		PRATIBHA PIPES AND STRUCTURES PVT LTD
		JCO GAS PIPES
		NUKAT TANK AND VESSELS
		GOODLUCK TUBES
		ADVANCE STEEL TUBES
		BIHAR TUBES
		HITECH PIPES
		RATNAMANI
		MAHARASHTRA SEAMLESS
14	GI SHEETS FOR DUCTING	TISCO
		INDIAN IRON & STEEL CO



## VENTILATION SYSTEM

### LIST OF MAKES OF SUB-VENDOR ITEMS

		RASHTRIYA ISPAT NIGAM LIMITED
		ESSAR
		ISPAT INDUSTRIES
		JSW
		LLOYDS
		BHUSHAN STEELS
		TATA
		SAIL
		JINDAL
15	GRILL/DIFFUSER/VOLUME CONTROL DAMPER	AIR FLOW
		TSC
		AIR MASTER
		CARRYAIRE
		RAVISTAR (SYSTEM AIR )
16	HUMID STAT	JHONSON CONTROL
		HONEYWELL AUTOMATION
		PENN
17	Y / POT STRAINER	MULTITEX
		GREAVES COTTON
		JAYPEE
		SANT VALVES
		OTOKLIN
		GRAND PRIX
		GUJARAT OTOLIFT
		DS ENGG
		SAROJINI ENTERPRISE
		BHATIA ENGINEERING
		FILTRATION ENGINEERS INDIA PVT LTD
		SUNGOV ENGINEERING
18	LOCAL CONTROL PANEL	INDUSTRIAL CONTROL & APPLIANCE
		PYROTECH ELECTRONICS PVT. LTD.
		POSITRONICS PVT. LTD.
		CONTROL & SWITCHGEAR
		SIEMENS
		L&T
		GE POWER
		RITTAL
		HOFFMAN

**VENTILATION SYSTEM****LIST OF MAKES OF SUB-VENDOR ITEMS****NOTES:**

1. \*Designed by Hyderabad Pollution Control / SK SYSTEM/ ADVANCE VENTILATION / DRAFT AIR/BLUE STAR/ VOLTAS/ STERLING WILSON/ROOTS COOLING SYSTEM/ C DOCTOR/ TAP/ Pack Plast/ Industrial projects and products & fabricated by their approved fabricator.
2. THE SUB VENDOR LIST ABOVE IS INDICATIVE ONLY AND IS SUBJECT TO BHEL AND CUSTOMER APPROVAL DURING DETAILED ENGINEERING STAGE WITHOUT ANY COMMERCIAL & DELIVERY IMPLICATION TO BHEL. BIDDER TO PROPOSE SUB VENDOR WITHIN 4 WEEKS OF PLACEMENT OF LOI. THEREAFTER NO REQUEST FOR ADDITIONAL SUB-VENDOR SHALL BE ENTERTAINED.
3. THE INSPECTION CATEGORY WILL BE INTIMATED AFTER AWARD OF CONTRACT BY BHEL/CUSTOMER. HOWEVER THE SAME WILL BE ADHERED BY THE BIDDER WITHOUT ANY COMMERCIAL AND DELIVERY IMPLICATION TO BHEL/ CUSTOMER.
4. PLEASE ALSO REFER RESPECTIVE SUB-SECTION C-3, C-4 FOR ELECTRICAL AND C&I RELATED EQUIPMENT LIST OF MAKE.

	<p align="center"><b>2x250 MW NSPCL BHILAI TPP (FGD SYSTEM PACKAGE) HVAC MANDATORY SPARE LIST</b></p>	<b>SPECIFICATION NO. PE-TS-468-553-A001</b>	
		<b>SECTION : I</b>	
		<b>SUB-SECTION : E</b>	
		<b>REV 00</b>	

**SECTION-I  
SUB SECTION -E**

**ANNEXURE-II  
MANDATORY SPARE LIST**

CLAUSE NO.	MANDATORY SPARES		
1.22.00	<p><b><u>AIR CONDITINING AND VENTILATION SYSTEM</u></b></p> <p>1.0 <b>Air handling unit (for each model)</b></p> <p>1.1 V-belts for AHU Blower 2 Sets</p> <p>1.2 AHU Blower bearing 1 Set</p> <p>1.3 Blower motor bearing 1 Set</p> <p>1.4 Filters at suction and discharge of all AHUs 25% of installed population</p> <p>2.0 <b>Unitary air filtration unit</b></p> <p>2.1 <i>Supply Air fans</i></p> <p>2.1.1 V-belts for supply air fans 2 Sets</p> <p>2.1.2 Supply air fan bearings 1 Set</p> <p>2.2 <i>UAF Pump</i></p> <p>2.2.1 Pump bearings 1 Set</p> <p>2.2.2 Impeller for pump 1 no.</p> <p>2.2.3 Pump Shaft 1 no.</p>		
<p>LOT-2 PROJECTS FLUE GAS DESULPHURISATION (FGD) SYSTEM PACKAGE</p>	<p>TECHNICAL SPECIFICATION SECTION – VI, PART-A BID DOC. NO.:CS-0011-109(2)-9</p>	<p>SUB-SECTION-VII MANDATORY SPARES</p>	<p>PAGE 31 OF 82</p>

CLAUSE NO.	MANDATORY SPARES		
	2.2.4 Shaft sleeves 2.2.5 Gland Packings for pumps 2.2.6 Nylon Filter 2.2.7 Spray nozzles 2.2.8 Water strainer 2.2.9 Brass suction screen/strainer for unitary air filtration tank. 2.2.10 Motor for Centrifugal fan for UAF <b>3.0 Control &amp; Instrumentation</b> i) Air-Conditioning System 3.1 Electronic Transmitters 3.1.1 Transmitters of all types and model no. (for the measurement of Pressure, differential pressure flow, level, temperature etc.) 3.2 Temperature elements 3.2.1 RTD's* 3.2.2 Thermo well * (With head assembly, terminal block and nipple) 3.3 All types of Local Indicators	1 Set 1 Set 1 Set 5% of total population or 50 Numbers whichever is higher. 1 No. 1 Set 1 No    5% or 1 No. of each type and model whichever is more. (to be divided into various ranges in proportion to main population)  5% or 1 No. which ever is more ** 5% or 1 No. which ever is more ** ** (to be divided into various insertion lengths in proportion to main population) 5% or 1 No. of each make, model and type whichever is more (to be divided to various ranges in	
LOT-2 PROJECTS FLUE GAS DESULPHURISATION (FGD) SYSTEM PACKAGE	TECHNICAL SPECIFICATION SECTION – VI, PART-A BID DOC. NO.:CS-0011-109(2)-9	SUB-SECTION-VII MANDATORY SPARES	PAGE 32 OF 82

CLAUSE NO.	MANDATORY SPARES		
		<p>proportion to main population of all make, model and type)</p> <p>3.4 Process Actuated Switch Devices Includes all types of Pressure, differential pressure, flow, and temperature, and differential temperature, level switch Devices. 5% or 1No. of each type and model whichever is more.</p> <p>3.5 Relative Humidity Sensors 1 No.</p> <p>3.6 Geysterstat 1 No.</p> <p>3.7 Local Humidity/Temperature indicators 2 Nos. each</p> <p>4.0 <b>Process Connection Piping (for Impulse Piping / Tubing, Sampling Piping / Tubing and Air Supply Piping as Applicable)</b></p> <p>4.1 Valves 10% or 1 No. of each type, class, size and model whichever is more.</p> <p>4.2 2 way, 3way, 5way valve manifolds 10% or 1 No. of each type, class, size and model whichever is more.</p> <p>4.3 Fittings 10% or 1 No. of each type, class, size and model whichever is more.</p> <p>(II) Ventilation System</p> <p>5.0 <b>Measuring Instruments</b></p> <p>5.1 Pressure Gauge 1 No. (for centrifugal pumps of UAF units).</p> <p>5.2 Level transmitter 1 No.</p> <p>5.3 Pressure transmitter 1 No. (for UAF units)</p> <p>6.0 <b>Process Connection Piping (for Impulse Piping / Tubing, Sampling Piping / Tubing and Air Supply Piping as Applicable)</b></p>	
<p>LOT-2 PROJECTS FLUE GAS DESULPHURISATION (FGD) SYSTEM PACKAGE</p>	<p>TECHNICAL SPECIFICATION SECTION – VI, PART-A BID DOC. NO.:CS-0011-109(2)-9</p>	<p>SUB-SECTION-VII MANDATORY SPARES</p>	<p>PAGE 33 OF 82</p>

CLAUSE NO.	MANDATORY SPARES		
	6.1 Valves	1 no. of each type, class, size and model	
	6.2 2 way valve manifold	1 no. of each type, class, size and model	
	6.3 Fittings	1 no. of each type, class, size and model	
<p align="center">LOT-2 PROJECTS FLUE GAS DESULPHURISATION (FGD) SYSTEM PACKAGE</p>	<p align="center">TECHNICAL SPECIFICATION SECTION – VI, PART-A BID DOC. NO.:CS-0011-109(2)-9</p>	<p align="center">SUB-SECTION-VII MANDATORY SPARES</p>	<p align="center">PAGE 34 OF 82</p>



	<b>2x250 MW NSPCL BHILAI TPP (FGD SYSTEM PACKAGE) HVAC SYSTEM PAINTING &amp; COLOUR SCHEME</b>	<b>SPECIFICATION No: PE-TS-468-(571-13000-A)-A001</b>	
		<b>SECTION : I</b>	
		<b>SUB-SECTION : E</b>	
		<b>REV 00</b>	

**SECTION-I**  
**SUB SECTION E**  
**ANNEXURE-III**  
**PAINTING & COLOUR SCHEME**  
**(REFER SECTION C2)**

	<p align="center"><b>2x250 MW NSPCL BHILAI TPP (FGD SYSTEM PACKAGE) HVAC SYSTEM PAINTING &amp; COLOUR SCHEME</b></p>	SPECIFICATION No: PE-TS-468-(571-13000-A)-A001	
		SECTION : I	
		SUB-SECTION : E	
		REV 00	

- For painting please refer the section C2-A.
- Color shall be as per IS 5.

	<b>2x250 MW NSPCL BHILAI TPP (FGD SYSTEM PACKAGE) HVAC LIST OF TOOLS &amp; TACKLES</b>	SPECIFICATION No: PE-TS-468-(571-13000-A)-A001	
		VOLUME : II B	
		SECTION : E	
		REV 00	

## ANNEXURE-IV

### LIST OF TOOLS & TACKLES REFER SUGGESTIVE PRICE FORMAT

	<b>2x250 MW NSPCL BHILAI TPP (FGD SYSTEM PACKAGE) HVAC SYSTEM DRAWINGS / DOCUMENTS SUBMISSION PROCEDURE</b>	SPECIFICATION No: PE-TS-468-(571-13000-A)-A001	
		SECTION : I	
		SUB-SECTION : E	
		REV 00	
<b>SHEET 1 OF 1</b>			

## SECTION-I

### SUB-SECTION-E

#### ANNEXURE-VI

#### DRAWINGS / DOCUMENTS SUBMISSION PROCEDURE

**(PLEASE REFER SECTION – I, SUB-SECTION C2B, GENERAL TECHNICAL REQUIREMENT)**

	<b>2x250 MW NSPCL BHILAI TPP (FGD SYSTEM PACKAGE) HVAC SYSTEM MASTER DRAWING LIST WITH SCHEDULE OF SUBMISSION</b>	SPECIFICATION No: PE-TS-468-(571-13000-A)-A001	
		SECTION : I	
		SUB-SECTION : E	
		REV 00	

## SECTION-I

### SUB-SECTION-E

#### ANNEXURE-VII

## MASTER DRAWING LIST WITH SCHEDULE OF SUBMISSION

	<b>2x250 MW NSPCL BHILAI TPP (FGD SYSTEM PACKAGE) HVAC SYSTEM MASTER DRAWING LIST WITH SCHEDULE OF SUBMISSION</b>	SPECIFICATION No: PE-TS-468-(571-13000-A)-A001	
		SECTION : I	
		SUB-SECTION : E	
		REV 00	

Sl. No.	DRG./ DOC. TITLE	DOCUMENT NO.	SCH. WEEK (FROM DATE OF LOI)
1	PE-V0-468-571-A001	ITEM CATEGORISATION AND SUB VENDOR LIST	3
2	PE-V0-468-571-A002	MQP OF CONDENSING UNIT	4
3	PE-V0-468-571-A003	MQP OF AHU	4
4	PE-V0-468-571-A004	MQP OF CENTRIFUGAL FAN	5
5	PE-V0-468-571-A005	MQP OF UAF	5
6	PE-V0-468-571-A006	MQP OF FILTERS	6
7	PE-V0-468-571-A007	MQP OF THERMAL INSULATION GLASS WOOL/ ROCK WOOL	6
8	PE-V0-468-571-A008	MQP OF THERMAL INSULATION NITRIL RUBBER/ POLEURETHANE FOAM/ POLYISOCYNURATE FOAM	6
9	PE-V0-468-571-A009	MQP OF CENTRIFUGAL PUMPS FOR UAF	6
10	PE-V0-468-571-A010	MQP OF PIPE	3
11	PE-V0-468-571-A011	MQP OF VALVE	7
12	PE-V0-468-571-A012	QAP OF VFD FOR AHU	8
13	PE-V0-468-571-A013	MANUFACTURING QUALITY PLAN FOR CPB	6
14	PE-V0-468-571-A101	HEAT LOAD CALCULATION FOR A/C SYSTEM OF FGD CONTROL BUILDING	1
15	PE-V0-468-571-A102	P & I DIAGRAM FOR AIR COOLED CONDENSING UNIT (DX- TYPE) FOR FGD CONTROL BUILDING	1
16	PE-V0-468-571-A103	HEAT LOAD CALCULATION FOR EVAPORATIVE COOLING SYSTEM OF FGD BUILDING	2
17	PE-V0-468-571-A104	P&ID FOR UAF UNIT FOR FGD BUILDING	2
18	PE-V0-468-571-A105	SCHEME OF AIR DISTRIBUTION IN FGD BUILDING	2
19	PE-V0-468-571-A201	TECHNICAL DATA SHEET OF CENTRIFUGAL FANS FOR AIR HANDLING UNITS AND UAF UNITS	4
20	PE-V0-468-571-A202	TECHNICAL DATA SHEET & GA OF AIR HANDLING UNITS	4
21	PE-V0-468-571-A203	TECHNICAL DATA SHEET & GA DRAWING OF UAF UNIT	5
22	PE-V0-468-571-A204	TECHNICAL DATA SHEET & GA DRAWING FOR CENTRIFUGAL PUMP FOR UAF UNIT	5
23	PE-V0-468-571-A205	TECHNICAL DATA SHEET FOR STRAINER OF VENTILATION SYSTEM	5
24	PE-V0-468-571-A206	TECHNICAL DATA SHEET & G.A. DRWG. FOR CAST IRON VALVES(GATE VALVE,CHECK VALVE, GLOBE VALVE) OF VENTILATION SYSTEM	6
25	PE-V0-468-571-A207	TECHNICAL DATA SHEET & G.A.DRWG. FOR BUTTERFLY VALVE	6
26	PE-V0-468-571-A208	TECHNICAL DATA SHEET & G.A. DRAWING OF FIRE DAMPER WITH ACTUATOR FOR A/C & VENTILATION SYSTEM	6
27	PE-V0-468-571-A209	TECHNICAL DATA SHEET & G.A DRAWING OF AIR-COOLED CONDENSING UNIT FOR FGD CONTROL	7

	<b>2x250 MW NSPCL BHILAI TPP (FGD SYSTEM PACKAGE)</b>	<b>SPECIFICATION No: PE-TS-468-(571-13000-A)-A001</b>	
	<b>HVAC SYSTEM</b>	<b>SECTION : I</b>	
	<b>MASTER DRAWING LIST WITH SCHEDULE OF SUBMISSION</b>	<b>SUB-SECTION : E</b>	
		<b>REV 00</b>	

		BUILDING	
28	PE-V0-468-571-A210	TECHNICAL DATA SHEET & G.A. DRAWING FOR HEATER PACKAGE AND PAN HUMIDIFIER	7
29	PE-V0-468-571-A211	TECHNICAL DATA SHEET & G.A. DRAWING OF AXIAL AIR FANS FOR A/C & VENTILATION SYSTEM ALONGWITH FIXING DETAILS AND GA OF PROPELLER FAN	6
30	PE-V0-468-571-A212	GA OF SUPPLY/RETURN AIR DIFFUSER/GRILL FOR A/C & VENTILATION SYSTEM	7
31	PE-V0-468-571-A213	TECHNICAL DATA SHEET FOR SPLIT AIR CONDITIONERS	7
32	PE-V0-468-571-A214	TECHNICAL DATA SHEET FOR THERMAL & ACCOUSTIC INSULATION FOR A/C & VENTILATION SYSTEM	8
33	PE-V0-468-571-A215	TECHNICAL DATA SHEET OF GI SHEET FOR AC AND VENTILATION SYSTEM	4
34	PE-V0-468-571-A216	TECHNICAL DATA SHEET AND GA OF FILTERS FOR AC AND VENTILATION SYSTEM	6
35	PE-V0-468-571-A217	TECHNICAL DATA SHEET OF PIPE FOR VENTILATION SYSTEM	4
36	PE-V0-468-571-A218	TECHNICAL DATA SHEET FOR INSTRUMENTS ( PRESSURE GAUGE, TEMPERATURE GAUGE, LEVEL GAUGE ETC) FOR AC AND VENTILATION SYSTEM	8
37	PE-V0-468-571-A219	TECHNICAL DATA SHEET AND GA OF MOTOR (PUMP, AHU, UAF, AXIAL FAN)	8
38	PE-V0-468-571-A220	TDS OF VFD FOR AHU	8
39	PE-V0-468-571-A221	GA DRAWING FOR CPB WITH DETAIL BOM WITH PAINTING DETAILS	6
40	PE-V0-468-571-A301	A/C EQUIPMENT LAYOUT (AHU & OUTDOOR UNITS) WITH COMPLETE FOUNDATION DETAIL FOR FGD CONTROL BUILDING	9
41	PE-V0-468-571-A302	A/C DUCT LAYOUT DRAWING FOR FGD CONTROL BUILDING AND OTHER MISC. CONTROL ROOMS	9
42	PE-V0-468-571-A303	EQUIPMENT LAYOUT OF UAF UNIT ALONGWITH FOUNDATION DETAIL FOR FGD BUILDING	10
43	PE-V0-468-571-A304	VENTILATION DUCT LAYOUT OF UAF UNIT FOR FGD BUILDING	10
44	PE-V0-468-571-A305	VENT. ARRANGEMENT FOR VARIOUS AUXILIARY BUILDING	12
45	PE-V0-468-571-A306	STANDARD DRAWING FOR DUCT FABRICATION & SUPPORTING ARRANGEMENT AND ERECTION & APPLICATION DETAIL OF INSULATION	6
46	PE-V0-468-571-A401	SPLIT AC SCHEDULE ALONGWITH HEAT LOAD CALCULATION FOR AUXILIARY BUILDING OF AC SYSTEM	10
47	PE-V0-468-571-A402	VENTILATION FAN SCHEDULE	8
48	PE-V0-468-571-A403	WRITE-UP & CONTROL PHILOSOPHY FOR A/C AND	4

	<b>2x250 MW NSPCL BHILAI TPP</b> <b>(FGD SYSTEM PACKAGE)</b> <b>HVAC SYSTEM</b> <b>MASTER DRAWING LIST WITH SCHEDULE</b> <b>OF SUBMISSION</b>	<b>SPECIFICATION No: PE-TS-468-(571-13000-A)-A001</b>	
	<b>SECTION : I</b>		
	<b>SUB-SECTION : E</b>		
	<b>REV 00</b>		

		VENTILATION SYSTEM	
49	PE-V0-468-571-A404	PG TEST PROCEDURE FOR A/C & VENTILATION SYSTEM	11
50	PE-V0-468-571-A405	OPERATION & MAINTENANCE MANUAL FOR A/C & VENTILATION SYSTEM	13
51	PE-V0-468-571-A406	CONTROL SCHEME/ LOGIC DIAGRAM (TO BE IMPLEMENTED) FOR AC AND VENTILATION SYSTEM	8
52	PE-V0-468-571-A407	INSTRUMENT & DRIVE LIST WITH SET POINTS & LOCATION DATA	10
53	PE-V0-468-571-A408	FIELD JB/LIE/LIR TERMINATIONS /GROUPING DOCUMENT	11
54	PE-V0-468-571-A409	RECOMMENDED CONTROL SCHEMES / LOGIC DIAGRAMS (TO BE IMPLEMENTED IN DDCMIS)	6
55	PE-V0-468-571-A410	INPUT / OUTPUT SIGNAL LIST (ANALOG & BINARY)	5
56	PE-V0-468-571-A411	ANNUNCIATION & SOE LIST	8
57	PE-V0-468-571-A412	CABLE SCHEDULE (IN BHEL EXCEL FORMAT) & CABLE INTERCONNECTION DETAILS	12
58	PE-V0-468-571-A413	HMI PICTURES/ PLANT SCHEMATICS/SYSTEM CONFIGURATION DIAGRAM	6
59	PE-V0-468-571-A414	INSTRUMENT HOOK UP DRAWING	10
60	PE-V0-468-571-A415	THERMOWELL SIZING CALCULATION	8
61	PE-V0-468-571-A501	MANDATORY SPARES LIST	12

## Notes:

1. The above drawing list is tentative and shall be finalized with the successful bidder after placement of order. While some of the drawings indicated above may not be applicable, some additional drawings may also be required based on scope of work.
2. Drawings shall be prepared in Auto-Cad latest edition. Required no. of hard and soft copies (editable) of the drawings shall be furnished as per requirement specified elsewhere in the specification.
3. Only manual calculation with authentic supporting literature (e.g. extracts of hand Book/ standard/codes) shall be acceptable. All design calculations and drawings shall be in SI system only.
4. All the drawings and documents including general arrangement drawing, data sheet, calculation etc. to be furnished to the customer during detailed engineering stage shall include / indicate the following details for clarity w.r.t. Inspection, construction, erection and maintenance etc.: -
  - a) All drawings and documents shall indicate the list of all reference drawings including general arrangement.
  - b) All drawings shall include / show plan, elevation, side view, cross - section, skin section, blow - up view; all major self-manufactured and bought out items shall be labeled and included in BOQ / BOM in tabular form.
  - c) Painting schedule shall also be made as a part of general arrangement drawing of each equipment / items indicating at least 3 trade names.



	<b>2x250 MW NSPCL BHILAI TPP (FGD SYSTEM PACKAGE)</b>	<b>SPECIFICATION No: PE-TS-468-(571-13000-A)-A001</b>	
	<b>HVAC SYSTEM</b>	<b>SECTION : I</b>	
	<b>MASTER DRAWING LIST WITH SCHEDULE OF SUBMISSION</b>	<b>SUB-SECTION : E</b>	
		<b>REV 00</b>	

- d) All the drawings required to be furnished to customer during detailed engineering stage shall include technical parameters, details of paints and lubrication, hardness and BOQ / BOM in tabular form indicating all major components including bought out items and their quantity, material of construction indicating its applicable code / standard, weight, make etc.
- e) Drawings/ documents to be submitted for purchasers review/ approval shall be under Revision A, B, C... etc. while drawings /documents to be submitted thereafter for customer's approval after purchaser's approval shall be under R-0, 1, 2, 3 .... etc.
- f) Drawings and documents not covered above but required to check safety of machines/ system, shall be submitted during detailed engineering stage without any commercial implication.
- g) All drawings shall include "B.O.M" and indicate quantity, material of construction, make along with IS/BS No., Technical parameters, dimensions, hardness, machining symbol and tolerance, requirement of radiography and hydraulic tests, painting details, elevation, side view, plan, skin section and blow-up view for clarity.
- h) All drawings shall be prepared as per BHEL's title block and shall bear BHEL's drawing No.
- i) Schedule of drawings submissions, comment incorporations & approval shall be as stipulated in the specifications. The successful bidder shall depute his design personnel to BHEL's/ Customer's/ Consultant's office for across the table resolution of issues and to get documents approved in the stipulated time.
- j) Bidder to follow the following the drawing submission schedule:
- k) 1st submission of drawings from date of LOI as per the submission schedule.
- l) Every revised submission incorporating comments – within 7 days.
- m) Bidder to submit revised drawings complete in all respects incorporating all comments. Any incomplete drawing submitted shall be treated as non-submission with delays attributable to bidder's account. For any clarification/ discussion required to complete the drawings, the bidder shall himself depute his personal to BHEL for across the table discussions/ finalizations/ submissions of drawings.

	<b>2x250 MW NSPCL BHILAI TPP (FGD SYSTEM PACKAGE) HVAC SYSTEM FORMAT FOR OPERATION AND MAINTENANCE MANUAL</b>	SPECIFICATION No: PE-TS-468-(571-13000-A)-A001	
		SECTION : I	
		SUB-SECTION : E	
		REV 00	

**SECTION-I**  
**SUB-SECTION-E**  
**ANNEXURE-VIII**  
**FORMAT FOR OPERATION AND MAINTENANCE  
MANUAL**

	<b>2x250 MW NSPCL BHILAI TPP (FGD SYSTEM PACKAGE) HVAC SYSTEM FORMAT FOR OPERATION AND MAINTENANCE MANUAL</b>	SPECIFICATION No: PE-TS-468-(571-13000-A)-A001	
		SECTION : I	
		SUB-SECTION : E	
		REV 00	

Project name :  
 Project number :  
 Package Name :  
 PO reference :  
 Document number :  
 Revision number :

Sl.no. & Sections	Description	Tick ( √ )if included in Manual			Remarks
		Yes	No	Not Applicable	
<b>1.</b>	<b>COVER PAGE</b>				
<b>1.1</b>	Project Name				
<b>1.2</b>	Customer/consultant Name				
<b>1.3</b>	Name of Package				
<b>1.4</b>	Supplier details with phone, FAX ,email address , Emergency Contact number				
<b>1.5</b>	Name and sign of prepared by , checked by & approved by				
<b>1.6</b>	Revision history with approval Details				
<b>2.0</b>	<b>INDEX</b>				
<b>2.1</b>	showing the sections & related page nos All the pages should be numbered section wise				
<b>3.0</b>	<b>DESCRIPTION OF PLANT/SYSTEM</b>				
<b>3.1</b>	Description /write up of operating principle of system equipment/ associated sub-systems & accessories/controls system , operating conditions, performance parameters under normal , start up and special cases				
<b>3.2</b>	Equipment list and basic parameter with Tag numbers				
<b>3.3</b>	Data sheets approved by Customer/for information and catalogues provided by original manufacturer				
<b>3.4</b>	Associated other packages and Interface /terminal points				
<b>3.5</b>	P&ID & Process Diagrams				
<b>3.6</b>	GA Layout drawings, As-built drawings , Actual photograph of items/system (Drawings of A2 & bigger sizes are to be attached in the last)				
<b>3.7</b>	Single line/wiring diagrams				
<b>3.8</b>	Control philosophy /control write-ups				

	<b>2x250 MW NSPCL BHILAI TPP (FGD SYSTEM PACKAGE) HVAC SYSTEM FORMAT FOR OPERATION AND MAINTENANCE MANUAL</b>	SPECIFICATION No: PE-TS-468-(571-13000-A)-A001	
		SECTION : I	
		SUB-SECTION : E	
		REV 00	

Sl.no. & Sections	Description	Tick ( ✓ ) if included in Manual			Remarks
		Yes	No	Not Applicable	
<b>4.0</b>	<b>COMMISSIONING ACTIVITIES (IF NOT COVERED IN SEPARATE DOCUMENT I.E. ERECTION MANUAL, COMMISSIONING MANUAL)</b>				
<b>4.1</b>	Pre-Commissioning Checks				
<b>4.2</b>	handling of items at site				
<b>4.3</b>	Storage at site				
<b>4.4</b>	Unpacking & Installation procedure				
<b>5.0</b>	<b>OPERATION GUIDELINES FOR PLANT PERSONAL/USER/OPERATOR</b>				
<b>5.1</b>	Interlock & Protection logic along with the limiting values of protection settings for the equipment along with brief philosophy behind the logic, drawings etc. to be provided.				
<b>5.2</b>	Start up, normal operation and shut down procedure for equipments along with the associated systems in step by step mode. Valve sequence chart, step list, interlocks etc. with Equipment isolating procedures to be mentioned.				
<b>5.3</b>	Do's & Don't of the equipments.				
<b>5.4</b>	Safety precautions to be taken during normal operation. Safety symbols, Emergency instructions on total power failure condition/lubrication failure/any other condition				
<b>5.5</b>	Parameters to be monitored with normal values and limiting values				
<b>5.6</b>	Trouble shooting with causes and remedial measures				
<b>5.7</b>	Routine operational checks, recommended logs & records				
<b>5.8</b>	Changeover schedule if more than one auxiliary for the same purpose is given				
<b>5.9</b>	Painting requirement and schedule				
<b>5.10</b>	Inspection, repair , Testing and calibration procedures				
<b>6.0</b>	<b>MAINTENANCE GUIDELINES FOR PLANT PERSONAL</b>				

	<b>2x250 MW NSPCL BHILAI TPP (FGD SYSTEM PACKAGE) HVAC SYSTEM FORMAT FOR OPERATION AND MAINTENANCE MANUAL</b>	<b>SPECIFICATION No: PE-TS-468-(571-13000-A)-A001</b>	
		<b>SECTION : I</b>	
		<b>SUB-SECTION : E</b>	
		<b>REV 00</b>	

Sl.no. & Sections	Description	Tick ( ✓ )if included in Manual			Remarks
		Yes	No	Not Applicable	
6.1	List of Special Tools and Tackles required for Overhaul/Trouble shooting including special testing equipment required for calibration etc.				
6.2	Stepwise dismantling and re-assembly procedure clearly specifying the tools to be used, checks to be made, records to be maintained, clearances etc. to be mentioned. Tolerances for fitment of various components to be given.				
6.3	Preventive Maintenance & Overhauling schedules linked with running hours/calendar period along with checks to be given				
6.4	Long term maintenance schedules especially for structural, foundations etc.				
6.5	Consumable list along with the estimated quantity required during commissioning, normal running and during maintenance like Preventive Maintenances and Overhaul. Storage/handling requirement of consumables/self-life.				
6.6	List of lubricants with their Indian equivalent, Lubrication Schedule, Quantity required for each equipment for complete replacement is to be given				
6.7	List of vendors & Sub-vendors with their latest addresses, service centres ,Telephone Nos., Fax Nos., Mobile Nos., e-mail IDs etc.				
6.8	List of mandatory and recommended spare parts list				
6.9	Tentative Lead time required for ordering of spares from the equipment supplier				
6.10	Guarantee and warranty clauses				
7.0	<b>Statutory and other specific requirements considerations.</b>				
8.0	<b>List of reference documents</b>				
9.0	<b>Binding as per requirement</b>				

	<p align="center">2x250 MW NSPCL BHILAI TPP (FGD SYSTEM PACKAGE) HVAC SYSTEM SITE STORAGE AND PRESERVATION</p>	SPECIFICATION No: PE-TS-468-(571-13000-A)-A001	
		SECTION : I	
		SUB-SECTION : E	
		REV 00	

**SECTION-I**  
**SUB-SECTION-E**  
**ANNEXURE-IX**  
**SITE STORAGE AND PRESERVATION**

# SITE STORAGE AND PRESERVATION GUIDELINES

## FOR

### MECHANICAL BOPs

(Doc No: PE-DC-SSG-A001 REV.00)



PROJECT ENGINEERING MANAGEMENT, POWER SECTOR  
BHARAT HEAVY ELECTRICALS LIMITED-NOIDA

## CONTENT

- 1 SCOPE OF THE DOCUMENT
- 2 PURPOSE OF STORAGE & PRESERVATION
- 3 MEASURES TO BE TAKEN FOR STORAGE AND PRESERVATION
  - a) GENERAL STORAGE REQUIREMENTS
  - b) GENERAL PRESERVATION REQUIREMENTS
  - c) GENERAL INSPECTION REQUIREMENTS
- 4 TYPE OF STORAGE FOR VARIOUS EQUIPMENT
5. CONCLUSION
6. STACKING ARRANGEMENT FOR PLATES AND STRUCTURAL STEEL



## 1. SCOPE OF THE DOCUMENT

This guideline is prepared in intent to provide proper site storage and preservation of the Mechanical, Electrical and C & I items / equipment supplied under various bought out packages/items. This storage procedure shall be followed at different power plant sites by concerned agency for storage and preservation from the date of equipment received at site until the same are erected and handed over to the customer.

## 2. PURPOSE OF STORAGE & PRESERVATION

Many of the items may be required to be kept in stores for long period. It shall therefore be essential that proper methods of storage and preservation be applied so that items do not deteriorate, loose some of their properties and become unusable due to atmospheric conditions and biological elements.

## 3. MEASURES TO BE TAKEN FOR STORAGE, HANDLING & PRESERVATION

### a) GENERAL STORAGE REQUIREMENTS

1. To the extent feasible, materials should be stored near the point of erection. The storage areas should have adequate unloading and handling facilities with adequate passage space for movement of material handling equipment such as cranes, fork lift trucks, etc. The storage of materials shall be properly planned to minimise time loss during retrieval of items required for erection.
2. The outdoor storage areas as well as semi-closed stores shall be provided with adequate drainage facilities to prevent water logging. Adequacy of these facilities shall be checked prior to monsoon.
3. The storage sheds shall be built in conformity with fire safety requirements. The stores shall be provided with adequate lights and fire extinguishers. 'No smoking' signs shall be placed at strategic locations. Safety precautions shall be strictly enforced.
4. Adequate lighting facility shall be provided in storage areas and storage sheds and security personnel positioned to ensure enforcement of security measures to prevent theft and loss of materials.
5. Adequate number of competent stores personnel and security staff shall be deployed to efficiently store and maintain the equipment / material.
7. The equipment shall be stored in an orderly manner, preserving their identification slips, tags and instruction booklets, etc., required during erection. The storage of materials shall be equipment-wise. Loose parts shall be stored in sheds on racks,

preserving the identification marks and tags in good condition. The group codes shall be displayed on the racks

6. At no time shall any materials be stored directly on ground. All materials shall be stored minimum 200 mm above the ground preferably on wooden sleepers

**b) GENERAL PRESERVATION REQUIREMENTS**

1. All special measures to prevent corrosion shall be taken like keeping material in dry condition, avoiding the equipment coming in contact with corrosive fluid like water, acid etc.
2. Materials which carry protective coating shall not be wrapped in paper, cloth, etc., as these are liable to absorb and retain moisture. The material shall be inspected and in case of signs of wear or damages to protective coating, that portion shall be cleaned with approved solution and coated with an approved protective paint. Complete record of all such observations and protective measures taken shall be maintained.
3. Generally equipment supplied at site are properly greased or rust protective oil is applied on machined/ fabricated components. However periodic inspection shall be carried out to ensure that protection offered is intact.
4. While handling the equipment, no dragging on the ground is permitted. Avoid using wire rope for lifting coated components. Use polyester slings (if possible) otherwise protective material (e.g. clothes, wood block etc.) should be used while handling the components with rope / slings
5. For Equipment supplied with finished paint, touch paint shall be done in case any surface paint gets peeled off during handling. Otherwise such surfaces shall necessarily be wrapped with polythene to avoid any corrosion. Further for equipment wherein finish coat is to be applied at site, site to ensure that equipment is received with primer coat applied.
6. It shall be ensured by periodic inspection that plastic inserts are intact in tapped holes, wherever applicable.
7. Pipes shall be blown with air periodically and it shall be ensured that there is no obstruction.
8. Silica gel or approved equivalent moisture absorbing material in small cotton bags shall be placed and tied at various points on the equipment, wherever necessary.
9. Heavy rotating parts in assembled conditions shall be periodically rotated to prevent corrosion/jamming due to prolonged storage.

10. All the electrical equipment such as motors, generators, etc. shall be tested for insulation resistance at least once in three months and a record of such measured insulation values shall be maintained.
11. Following preservatives/preservation methods can be used depending upon type of equipment
  - a. Rust preventive fluid (RPF)
  - b. Rust protective paints
  - c. Tarpaulin covers, in case of outdoor storage
  - d. De-oxy aluminate for weld-ments

**c) GENERAL INSPECTION REQUIREMENTS**

1. Period inspection of materials with specific reference to –
  - Ingress of moisture and corrosion damages.
  - Damage to protective coating.
  - Open ends in pipes, vessels and equipment -
    - In case any open ends are noticed, same shall be capped.
2. Any damages to equipment / materials.
  - In case of any damages, these shall be promptly notified and in all cases, the repairs / rectification shall be carried out.
  - Any items found damaged or not suitable as per project requirements shall be removed from site. If required to store temporarily, they shall be clearly marked and stored separately to prevent any inadvertent use.

#### 4. TYPE OF STORAGE FOR VARIOUS EQUIPMENT

The types of storage are broadly classified under the following heads:

i **Closed storage with dry and dust free atmosphere. (C )**

The closed shed can be constructed by using cold-rolled / tubular components for structure and corrugated asbestos sheets / galvanised iron sheets for roofing. Brick walls / asbestos sheets can be used to cover all the sides. The floor of the shed can be finished with plain cement concrete suitably glazed. The shed shall be provided with proper ventilation and illumination.



ii **Semi-closed storage. (S)**

The semi closed shed can be constructed by using cold-rolled / tubular components for structure and corrugated / asbestos sheets for roofing. The floor shall be brick paved. If required a small portion of sides can be covered to protect components from rainwater splashing onto the components.





iii Open storage (O )

The open yard shall be levelled, well consolidated to achieve raised ground with the provision of feeder roads for crane approach along with access roads running all sides. One part of the open yard shall be stone pitched, levelled and consolidated with raised ground suitable for storing / stacking heavier and critical components with due space to handle them by cranes etc . Adequate number of sleepers, concrete block etc. to be provided to make raised platforms to stack critical materials.

A separate yard to be identified as “scrap yard” slightly away from main open yard to store wooden/steel scraps, which are to be disposed off. This is required to avoid mix up with regular components as well as to avoid fire hazard.

Some of the components, which are having both machined & un-machined surfaces and are bulky, shall be stored in open storage area on a raised ground and suitably covered with water proof / fire retardant tarpaulin.



## 46442/2020/PS-PEM-MAX

The equipment listed below shall be stored and inspected as per requirement mentioned in the table below.

Sl. No.	Description of the equipment	Type of Storage	Check for	Remarks
<b>Raw material /mechanical items like pipes, plates, structure sections etc.)</b>				
1.	Steel pipes ( lined/unlined)	S	Damage , paint, corrosion, rubber lining peeling	Provide end cap
2.	MS Plates	S	Damage, paint, corrosion	
3.	SS Plates	S	Damage	
4.	Non-metallic pipes	S	Damage, cracks	Provide end cap
5.	Stainless steel pipes	S	Damage ,	Provide end cap
6.	MS sections, beams	S	Damage, paint, corrosion	
7.	Cable trays	S	Damage, condition of preservations	
8.	Insulation sheets	S	Damage	
9.	Insulation	C	Damage, packing	
10.	Hangers Rods	S	Damage, paint, packing	
11.	Tubes	S	Damage, paint , packing	Provide end cap
12.	Hume pipes	O	Damage	
13.	Castings	O	Damage, paint, corrosion	
<b>Fabricated mechanical items (pressure vessels, tanks etc.)</b>				
14.	Pressure vessels (unlined)	O	Damage, paint, corrosion,	Covered nozzles
15.	Atmospheric storage tanks (unlined)	O	Damage, paint, corrosion	Covered nozzles

Sl. No.	Description of the equipment	Type of Storage	Check for	Remarks
16.	Pressure vessels (lined)	S	Damage, paint, corrosion, rubber lining	
17.	Atmospheric storage tanks(lined)	S	Damage, paint, corrosion, rubber lining	
18.	Support structures	O	Damage , paint, corrosion	
19.	Flanges	C	Damage , paint, corrosion	
20.	Fabricated pipes	S	Damage , paint, corrosion	Provide end cap
21.	Vessels internals	C	Damage , paint, corrosion ,packing	
22.	Grills	S	Damage , paint, corrosion	
23.	Angles	S	Damage , paint, corrosion	
24.	Bridge mechanism/clarifier mechanism	O	Damage , paint, corrosion	
25.	Cranes, rails	S	Damage , paint, corrosion	
26.	Stair cases	O	Damage , paint, corrosion	
27.	Ladders/handrails	O	Damage , paint, corrosion	
28.	Fabricated ducts	S	Damage , paint, corrosion	
29.	Isolation Gates	O	Damage , paint, corrosion	
30.	Fabricated boxes/panels	S	Damage , paint, corrosion	
<b>Mechanical components like valves, fittings, cables glands, spares etc.)</b>				
31.	Valves	S	Damage , packing	

Sl. No.	Description of the equipment	Type of Storage	Check for	Remarks
32.	Fittings	S	Damage , packing	Provide end cap
33.	Cable glands	C	Damage , packing	
34.	Tools & tackles	C	Damage , packing	
35.	Nut , bolts, washers,	C	Damage , packing	
36.	Gasket & Packings	C	Damage , packing	
37.	Copper tubes	C	Damage , packing, corrosion	Provide end cap
38.	SS tubing	C	Damage , packing	Provide end cap
<b>Rotating assemblies (pumps, blowers, stirrers, fans, compressors etc.)</b>				
39.	Pumps	S	Damage , packing, corrosion	Shaft rotation
40.	Blowers/Compressors	S	Damage , packing, corrosion	Shaft rotation
41.	Agitators/stirrers/radial launders	C	Damage , packing, corrosion	Shaft rotation
42.	Rollers for chlorine tonner mounting	C	Damage , packing, corrosion	
43.	Centrifuge	S	Damage , packing,	
44.	Gear box	C	Damage , packing, corrosion	
45.	Bearings	C	Damage , packing, corrosion	
46.	Fans	S	Damage , packing, corrosion	
47.	Dosing skids	S	Damage , packing, corrosion	
48.	Pump assemblies	S	Damage , packing, corrosion	
49.	Air washers( INTERNALS)	S	Damage , packing	
50.	Air conditioners ( split)	C	Damage , packing	



Sl. No.	Description of the equipment	Type of Storage	Check for	Remarks
51.	Elevators( CONTAINERIZED)	O	Damage , packing, corrosion	
52.	Chillers/VA machines	S	Damage , packing	
53.	Air handling Unit/Package unit	S	Damage , packing	
54.	Chlorinators & Evaporators	C	Damage , packing	
55.	Ejectors	C	Damage , packing	
56.	Electrolyser	C	Damage , packing	
<b>Miscellaneous items like chain pulley blocks, hoists etc.</b>				
57.	Chain pulley blocks	S	Damage, Packing	
58.	Electric hoists	S	Damage, Packing	
59.	Fire extinguishers	C	Damage, expiry date	
60.	Fork Lift Truck	S	Damage, Packing	
61.	Hydraulic Mobile Crane	O	Damage, Packing	
62.	Mobile Pick Up & Carry Crane	O	Damage, Packing	
63.	Motor boats	O	Damage, Packing	
64.	Safety showers	S	Damage, Packing	
65.	Diffusers/dampers	S	Damage, Packing	
<b>Chemicals and consumables ( acid, alkali, paints, oils, reagents and special chemicals)</b>				
66.	Hydro Chloric Acid (HCl)	Store in canes/ storage tank in dyke area	Date of production/ leakage/fumes	hazardous chemical
67.	Sulphuric acid (H <sub>2</sub> SO <sub>4</sub> )	Store in canes/ storage tank in dyke area	Date of production/ leakage/fumes	hazardous chemical

Sl. No.	Description of the equipment	Type of Storage	Check for	Remarks
68.	Sodium hydroxide (NaOH)	Store in canes/ storage tank in dyke area	Date of production/ leakage/ fumes/ breather	hazardous chemical ,breather to be checked for air ingress
69.	Sodium hypo chlorite	To be stored under shed	Date of production/ leakage/ fumes	hazardous chemical ,self-life normally 15-30 days after which strength of chemical decays
70.	Ammonia	S	Date of production/ leakage/ fumes	Store in closed storage tanks, hazardous chemical
71.	CW treatment chemicals	S	Date of production , Self-life	Store in closed canes
72.	RO/UF cleaning chemicals	S	Date of production , Self-life	Store in closed canes
73.	Lime	C	Damage to packing , seepage	Prevent moisture, rain
74.	Alum bricks	C	Damage to packing	Prevent moisture, rain
75.	Poly electrolyte	S		Store in closed storage tanks
76.	Laboratory chemicals( powder)	C	Damage, Packing self- life	
77.	Laboratory chemicals( liquid)	C	Damage, Packing self- life	
78.	Lubrication oils	C	Leakage	
79.	Paints	S	Leakage ,air tightness	
80.	Sand	O	Damage of packing	No hooks
81.	Salt (NaCl)	C	Damage of packing, water ingress	Prevent moisture, rain
82.	Anthracite	S	Damage of packing	
83.	Activated carbon	S	Damage of packing	

Sl. No.	Description of the equipment	Type of Storage	Check for	Remarks
84.	Thermal insulation	S	Damage of packing	
85.	Cement	C	Damage of packing	Prevent moisture, rain
86.	Gravels	O	Damage of packing	
87.	ION exchange resins	C	Damage , packing	Refer manufacturer guidelines
88.	RO membranes	C	Damage , packing	Refer manufacturer guidelines
89.	UF membranes	C	Damage , packing	Refer manufacturer guidelines
90.	Cleaning chemicals	C	Damage , packing	Refer manufacturer guidelines
91.	Chemicals for analysers/calibration	C	Damage , packing	Refer manufacturer guidelines
<b>Electrical and C &amp; I items (motors, cables etc.)</b>				
92.	Motors	C	Damage , packing	
93.	Cable drums	O	Damage	
94.	Control Panel /control desk, UPS ,JB	S	Damage, Packing	
95.	Instruments( gauges/analysers)	C	Damage	
<b>Special items</b>		As per Manufacturer's item, like Hydrogen cylinders, Ozonator, Analyser, Chlorine dioxide generators etc.		

## 5. CONCLUSION

Concerned storage agency at site should make sure that loss in equipment performance and wear & tear are minimised through proper storage and preservation. The above are broad guidelines and cover major equipment / materials. However specific storage practices shall be followed as per manufacturer recommendation. All the necessary measures even in addition to the ones mentioned above, if found necessary, should be taken to achieve the objective.

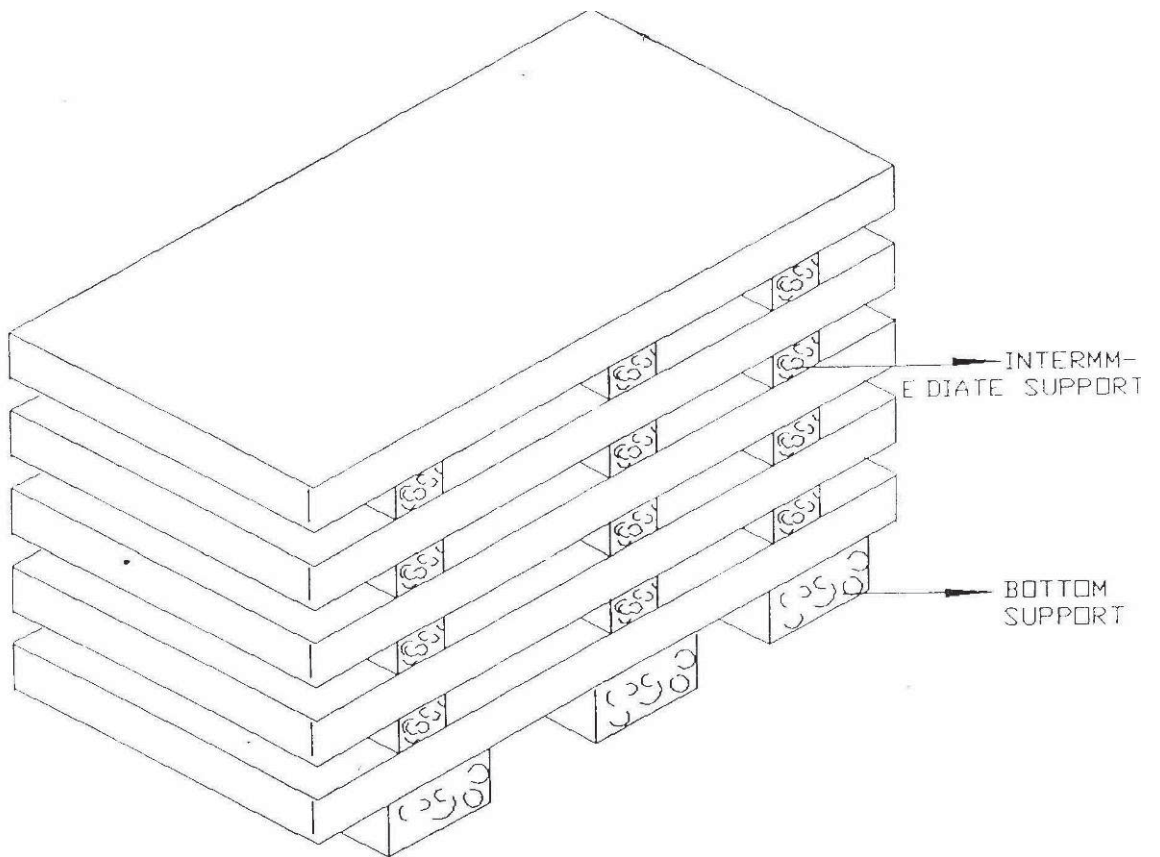

Figure – 1 – PLATE STACKING ARRANGEMENT

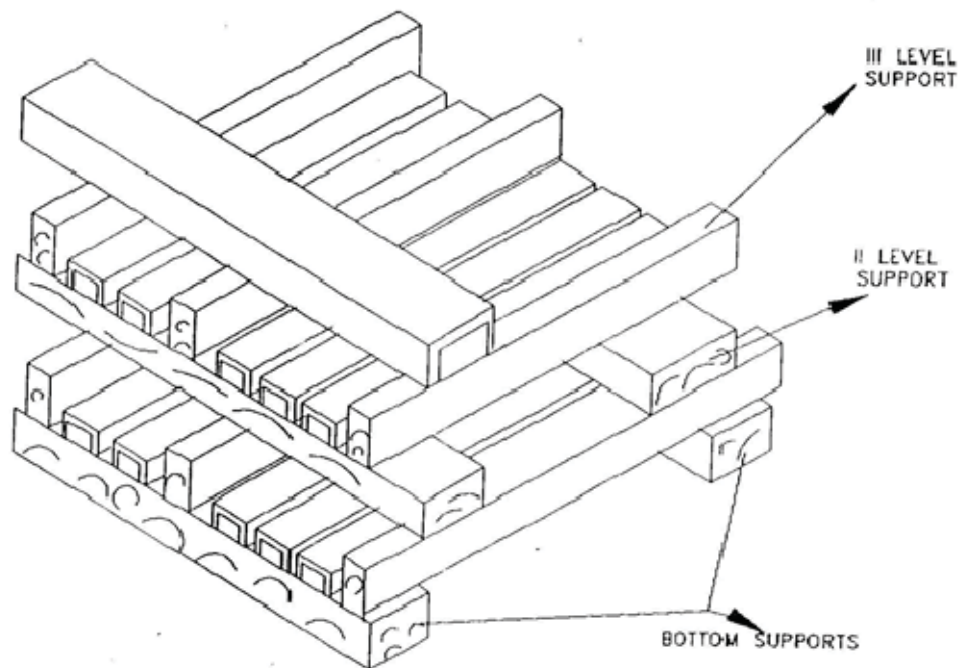

Figure – 2 – STRUCTURAL STEEL STACKING ARRANGEMENT



**2x250 MW NSPCL BHILAI TPP  
(FGD SYSTEM PACKAGE)  
HVAC SYSTEM**

**SPECIFICATION No: PE-TS-468-(571-13000-A)-A001**

**SECTION: II**

**REV. 00**

## **SECTION II**

	<b>2x250 MW NSPCL BHILAI TPP (FGD SYSTEM PACKAGE) HVAC SYSTEM INSPECTION AND TESTING</b>	<b>SPECIFICATION No: PE-TS-468-(571-13000-A)-A001</b>	
		<b>SECTION : II</b>	
		<b>SUB-SECTION : 1</b>	
		<b>REV 00</b>	

**SECTION-II**  
**SUB-SECTION-1**  
**INSPECTION AND TESTING**

	<b>2x250 MW NSPCL BHILAI TPP (FGD SYSTEM PACKAGE) HVAC SYSTEM INSPECTION AND TESTING</b>	<b>SPECIFICATION No: PE-TS-468-(571-13000-A)-A001</b>	
		<b>SECTION : II</b>	
		<b>SUB-SECTION : 1</b>	
		<b>REV 00</b>	
1.01.00	<p>Inspection and Tests during Manufacture.</p>		
1.01.01	<p>The method and techniques to be used by the Bidder for the control of quality during manufacture of all plant and equipment shall be agreed with the Owner.</p>		
1.01.02	<p>The Owner's general requirements with respect to quality control and the required shop tests are set out elsewhere in this specification.</p>		
1.01.03	<p>Before any item of plant or equipment leaves its place of manufacture the Owner shall be given the option of witnessing inspections and tests for compliance with the specification and related standards.</p>		
1.01.04	<p>Advance notice shall be given to the Owner as agreed in the Contract, prior to the stage of manufacture being reached, and the piece of plant must be held at this stage until the Owner has inspected the piece, or has advised in writing that inspection is waived. If having consulted the Owner and given reasonable notice in writing of the date on which the piece of plant will be available for inspection, the Owner does not attend the Bidder may proceed with manufacture having forwarded to the Owner duly certified copies of his own inspection and test results.</p> <p>The owner's representative shall have at all reasonable times access to bidder's or his sub-vendor's premises and shall have power to inspect/ examine materials and workmanship or equipment under manufacture.</p> <p>The Bidder shall forthwith forward to the engineer duly certified copies of the Test Certificates in six copies (one to the Purchaser and five to the Consulting Engineer) for approval. Further nine (9) copies of Shop Test Certificates shall be bound with Instruction Manuals referred to elsewhere.</p> <p>For electrical equipment, routine tests as per relevant IS spec are to be carried out on all equipment. Type tests are also to be carried out on selected equipment as detailed in the specs of concerned electrical equipment.</p>		
1.01.05	<p>Under no circumstances any repair or welding of castings be carried out without the consent of the Engineer. Proof of the effectiveness of each repair by radiographic and/or other non-destructive testing technique, shall be provided to the Engineer.</p>		
1.01.06	<p>All the individual and assembled rotating parts shall be statically and dynamically balanced in the works.</p> <p>Where accurate alignment is necessary for component parts of machinery normally assembled on site, the Bidder shall allow for trial assembly prior to dispatch from place of manufacture.</p>		
1.01.07	<p>All materials used for the manufacture of equipment covered under this specification shall be of tested quality. Relevant test certificates shall be made available to the Purchaser. The certificates shall include tests for mechanical properties and chemical analysis of representative material. Equipment or parts coming under any statutory</p>		



	<b>2x250 MW NSPCL BHILAI TPP (FGD SYSTEM PACKAGE) HVAC SYSTEM INSPECTION AND TESTING</b>	<b>SPECIFICATION No: PE-TS-468-(571-13000-A)-A001</b>	
		<b>SECTION : II</b>	
		<b>SUB-SECTION : 1</b>	
		<b>REV 00</b>	
	<p>Regulations shall be certified by a Competent Authority under the regulations in the specified format.</p>		
1.01.08	<p>All pressure parts connected to pumping main shall be subjected to hydraulic testing at a pressure of 150% of shut-off head for a period not less than one hour. Other parts shall be tested for one and half times the maximum operating pressure, for a period not less than one hour.</p>		
1.01.09	<p>All necessary non-destructive examinations shall be performed to meet the applicable code requirements.</p>		
1.01.10	<p>All welding procedures adopted for performing welding work shall be qualified in accordance with the requirements of Section-IX of ASME code or IBR as applicable. All welded joints for pressure parts shall be tested by liquid penetrant examination according to the method outlined in ASME Boiler and Pressure Vessel code. Radiography, magnetic particle examination magnuflux and ultrasonic testing shall be employed wherever necessary/ recommended by the applicable code. At least 10% of all major but welding joints shall be radiographed unless otherwise stipulated.</p> <p>Statutory payments in respect of IBR approvals including inspection shall be made by the bidder. Bidder's scope shall include to preparation of all necessary documents, co-ordination and follow-up for above approval. Owner shall only forward assistance/endorsement of documents /design /drawings /reports/records to be submitted for approval as stipulated/ required by Statutory Authorities till registration of the unit and clearance for commercial operation.</p>		
1.02.00	<p>Performance Tests at Site</p>		
1.02.01	<p>The full requirements for testing the system shall be agreed between the Owner and the Bidder prior to Award of Contract. The completely erected System shall be tested by the Bidder on site under normal operating conditions. The Bidder shall also ensure the correct performance of the System under abnormal conditions, i.e. the correct working of the various emergency and safety devices, interlocks, etc.</p>		
1.02.02	<p>The Bidder shall provide complete details of his normal procedures for testing, for the quality of erection and for the performance of the erected plant. These tests shall include site pressure test on all erected pipe work to demonstrate the quality of the piping and the adequacy of joints made at site.</p>		
1.02.03	<p>The Bidder shall furnish the quality procedures to be adopted for assuring quality from the receipt of material at site, during storage, erection, pre-commissioning to tests on completion and commissioning of the complete system/equipment.</p>		
1.03.00	<p>For details of specific tests required on individual equipment refer to respective section of this specification.</p> <p>All Statutory testing / clearance is in Bidder's scope including payment of all fees, etc. as required</p>		



	<p align="center"><b>2x250 MW NSPCL BHILAI TPP (FGD SYSTEM PACKAGE) HVAC SYSTEM LIST OF DOCUMENTS TO BE SUBMITTED WITH BID</b></p>	SPECIFICATION No: PE-TS-468-(571-13000-A)-A001	
		SECTION : II	
		SUB-SECTION : 2	
		REV: 00	
		SHEET 1 OF 1	

**BIDDER SHOULD SUBMIT THE SIGNED AND STAMPED COPY OF THE FOLLOWING DOCUMENTS:**

1. Compliance cum confirmation certificate
2. Guaranteed power consumption (In the format attached in the spec mentioning KW rating).
3. Unpriced-price format mentioning Quoted / Not Applicable as the case may be against each column and row.
4. Deviation schedule /No deviation certificate in attached format 'Deviation sheet (Cost of withdrawal)'.
5. Pre-bid clarification Schedule, if any
6. Technical Corrigenda to tender specification, if any.

Offer will be considered as incomplete in absence of any of the above documents. Bidder to ensure that all above documents are available in their offer, failing to which bidder offer is liable to be rejected.

Any other document apart from above submitted along with bid will not be taken cognizance off and will not make any part of the contract and accordingly will not be considered for bid evaluation.



**2x250 MW NSPCL BHILAI TPP  
(FGD SYSTEM PACKAGE)  
HVAC SYSTEM  
COMPLIANCE CUM CONFIRMATION  
CERTIFICATE**

**SPECIFICATION No: PE-TS-468-(571-13000-A)-A001**

**SECTION : II**

**SUB-SECTION : 3**

**REV. NO. 00**

**SHEET: 1 OF 2**

**COMPLIANCE CUM CONFIRMATION CERTIFICATE**

The bidder shall confirm compliance with following by signing / stamping this compliance certificate (every sheet) and furnish same with the offer.

- a) The scope of supply, technical details, construction features, design parameters etc. shall be as per technical specification & there are no exclusions, other than those mentioned under "exclusion and those resolved as per 'Schedule of Deviations', with regard to same.
- b) There are no other deviations w.r.t. specifications other than those furnished in the 'Schedule of Deviations'. Any other deviation, stated or implied, taken elsewhere in the offer stands withdrawn unless specifically brought out in the 'Schedule of Deviations'
- c) Bidder shall submit QP in the event of order based on the guidelines given in the specification & QP enclosed therein. QP will be subject to BHEL / CUSTOMER approval & customer hold points for inspection / testing shall be marked in the QP at the contract stage. Inspection / testing shall be witnessed as per same apart from review of various test certificates/ Inspection records etc. This is within the contracted price without any extra implications to BHEL after award of the contract.
- d) All drawings/ data-sheets / calculations etc. submitted along with the offer shall not be taken cognizance off.
- e) The offered materials shall be either equivalent or superior to those specified in the specification & shall meet the specified / intended duty requirements. In case the material specified in the specifications is not compatible for intended duty requirements then same shall be resolved by the bidder with BHEL during the pre-bid discussions, otherwise BHEL / Customer's decision shall be binding on the bidder whenever the deficiency is pointed out.

For components where materials are not specified, same shall be suitable for intended duty, all materials shall be subject to approval in the event of order.

- f) The commissioning spares shall be supplied on 'As Required Basis' & prices for same included in the base price itself.
- g) All sub vendors shall be subject to BHEL / CUSTOMER approval in the event of order.
- h) Guarantee for plant/equipment shall be as per relevant clause of GCC / SCC / Other Commercial Terms & Conditions
- i) In the event of order, all the material required for completing the job at site shall be supplied by the bidder within the ordered price even if the same are additional to approved billing break up, approved drawing or approved Bill of quantities within the scope of work as tender specification. This clause will apply in case during site



**2x250 MW NSPCL BHILAI TPP  
(FGD SYSTEM PACKAGE)  
HVAC SYSTEM  
COMPLIANCE CUM CONFIRMATION  
CERTIFICATE**

**SPECIFICATION No: PE-TS-468-(571-13000-A)-A001**

**SECTION : II**

**SUB-SECTION : 3**

**REV. NO. 00**

**SHEET: 2 OF 2**

commissioning, additional requirements emerges due to customer and / or consultant's comments. No extra claims shall be put on this account

- j) Schedule of drawings submissions, comment incorporations & approval shall be as stipulated in the specifications. The successful bidder shall depute his design personnel to BHEL's / Customer's / Consultant's office for across the table resolution of issues and to get documents approved in the stipulated time.
- k) As built drawings shall be submitted as and when required during the project execution.
- l) The bidder has not tempered with this compliance cum confirmation certificate and if at any stage any tempering in the signed copy of this document is noticed then same shall be treated as breach of contract and suitable actions shall be taken against the bidder.
- m) Successful bidder shall furnish detailed erection manual for each of the equipment supplied under this contract at least 3 months before the scheduled erection of the concerned equipment / component or along with supply of concerned equipment / component whichever is earlier.
- n) Document approval by customer under Approval category or information category shall not absolve the vendor of their contractual obligations of completing the work as per specification requirement. Any deviation from specified requirement shall be reported by the vendor in writing and require written approval. Unless any change in specified requirement has been brought out by the vendor during detail engineering in writing while submitting the document to customer for approval, approved document (with implicit deviation) will not be cited as a reason for not following the specification requirement.
- o) In case vendor submits revised drawing after approval of the corresponding drawing, any delay in approval of revised drawing shall be to vendor's account and shall not be used as a reason for extension in contract completion.



	<p style="text-align: center;"><b>2X250 MW NSPCL TPP (FGD SYSTEM PACKAGE) HVAC SYSTEM NO DEVIATION CERTIFICATE</b></p>	SPECIFICATION No: PE-TS-468-(571-13000-A)-A001	
		SECTION : II	
		SUB-SECTION : 5	
		REV: 00	
		SHEET 1 OF 1	

**NO DEVIATION CERTIFICATE  
Annexure-II Deviation sheet (Cost of withdraw)**







**2x250 MW NSPCL BHILAI TPP  
(FGD SYSTEM PACKAGE)  
HVAC SYSTEM  
GAURANTEE POWER CONSUMPTION**

**SPECIFICATION No: PE-TS-468-(571-13000-A)-A001**

**SECTION : II**

**SUB-SECTION : 6**

**REV. NO. 00**

**SHEET: 1 OF 1**

<b>GUARANTEED POWER CONSUMPTION</b>						
<b>NAME OF PROJECT:</b>		<b>2x250 MW NSPCL BHILAI TPP (FGD SYSTEM PACKAGE)</b>				
<b>NAME OF PACKAGE:</b>		<b>HVAC FOR FGD SYSTEM</b>				
<b>TECHNICAL SPECIFICATION No:</b>		<b>PE-TS-468-(571-13000-A)-A001</b>				
S.NO.	DESCRIPTION OF EQUIPMENT	NO OF EQUIPMENT		TOTAL GUARANTEED POWER CONSUMPTION FOR EACH EQUIPMENT AT MOTOR INPUT TERMINAL AND CONTROL PANEL (IN KW)	DUTY FACTOR	TOTAL KW
		WORKING	STANDBY			
		3A	3B	4	5	6=3Ax4x5
<b>1</b>	<b>AC SYSTEM</b>					
<b>1.1</b>	<b>AIR COLLED CONDENSING UNIT</b>					
<b>1.1.1</b>	<b>OUTDOOR UNIT</b>	1	1		1	
<b>1.1.2</b>	<b>AHU FAN</b>	1	1		1	
<b>2</b>	<b>VENTILATION SYSTEM</b>					
<b>2.1</b>	<b>UAF</b>					
<b>2.1.1</b>	<b>UAF FAN</b>	1	0		1	
<b>3.0</b>	<b>TOTAL GPC FOR STATION (KW)</b>					

Note: Estimated power consumption (EPC) figure for the system (for working drives only) has been considered as **80 KW**. So long bidder's quoted guaranteed power consumption (GPC) above remains within this EPC, there will be no technical loading of bid on power consumption for evaluation. However, if bidder's quoted GPC exceeds EPC, there shall be technical loading of bid for evaluation @ **INR 1,36,930/- per KW** of additional power over EPC.

Bidder's guaranteed power consumption at motor input terminals (not shaft power) as furnished in relevant schedule shall be demonstrated by the successful bidder during performance testing at works/ site. In case power consumption is noted higher than EPC / bidder's quoted GPC whichever is higher, during inspection/ PG test, penalty **INR 1,36,930/- per KW** shall be levied on vendor.

Above guaranteed power consumption value shall be at 20 deg. C for centrifugal fans for AHUs and 30 deg. C for centrifugal fans of UAF units and at an elevation of RL of site for both AHUs and UAF centrifugal fans.

**Particulars of bidder / authorised representative**

Name	Designation	Signature	DATE	Company Seal

	<p style="text-align: center;"><b>2X250 MW NSPCL BHILAI TPP (FGD SYSTEM PACKAGE) HVAC SYSTEM</b></p> <p style="text-align: center;"><b>DRAWING / DOCUMENTS ENCLOSED WITH THE SPECIFICATION</b></p>	<b>SPECIFICATION No: PE-TS-468-(571-13000-A)-A001</b>	
		<b>SECTION : II</b>	
		<b>SUB-SECTION : 7</b>	
		<b>REV: 00</b>	
		<b>SHEET 1 OF 1</b>	

**Following drawings are enclosed with the Technical Specification**

1. PE-DG-468-(571-13000A)-A101, P&ID for Air Cooled Condensing Unit for FGD
2. PE-DG-468-(571-13000A)-A102, P&ID for UAF for FGD
3. PE-DG-468-(571-13000A)-A003, Scheme for HVAC Make Up Water
4. PE-DG-468-100-E001, Layout for Electrical & Control Room Building (FGD)
5. PE-DG-468-571-A001, GA of Gypsum Dewatering Building

PE-DG-468-(571-13000-A)-A101

**AHU ROOM, FGD CONTROL ROOM**

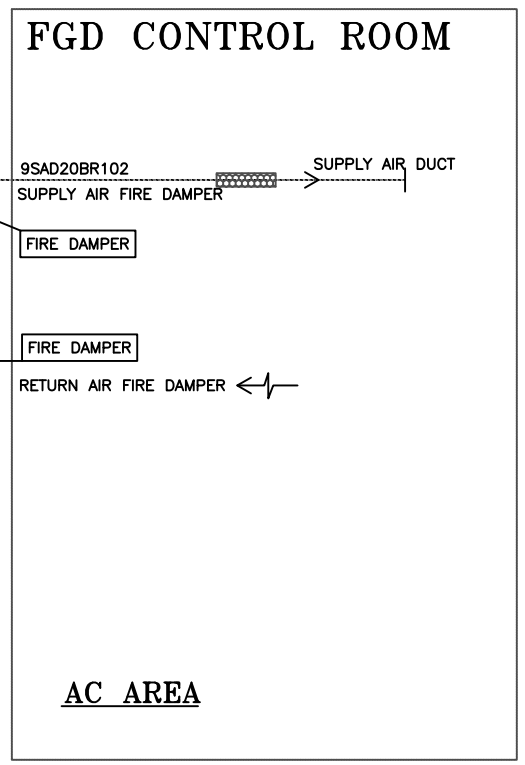

**DX AIR HANDLING UNIT**  
(1 WORKING & 1 STANDBY)

**AIR COOLED DX TYPE AC**  
**LOCATION: FGD CONTROL ROOM BUILDING**

LEGEND					
SYMBOL	DESCRIPTION	TAG	SYMBOL	DESCRIPTION	TAG
	TEMPERATURE GAUGE	TI		PRESSURE TEST POINT	PX
	PRESSURE GAUGE	PI		TEMPERATURE ELEMENT	TE
	VENT VALVE	-		HUMIDITY SENSOR	RHS
	PURGE VALVE.	MBF		NON RETURN DAMPER	NRD
	PRE FILTER	3MV		FIRE DAMPER (MOTOR OPERATED)	FD
	FINE FILTER	P		VOLUME CONTROL DAMPER.	VCD
	HEPA FILTER	-		LEVEL SWITCH (LOW/HIGH)	LS
	ELECTRICAL LINE	E		DESCALING TEE	-
	PAN HUMIDIFIER	PH		AIRSTAT	AT
	LOW LEVEL SWITCH	LLS		FIRE DAMPER (MOTOR OPERATED)	FD
	TEMP. TEST POINT	TX		FINNED TYPE STRIP HEATER	-
	DIFFERENTIAL PRESSURE SWITCH	DPS		GEYSERS THERMOSTAT	GT
	TEMPERATURE SENSOR	TS		HIGH LEVEL SWITCH	HLS
	SIGNAL TO DCS	D		AIR LINE PRESSURE SWITCH	PS
	PRESSURE TRANSMITTER	PT		HIGH LEVEL SWITCH	HLS
			SUPPLY AND RETURN AIR DUCT		

**NOTES:**

1. ALL SUPPLY & RETURN DUCT SHALL BE INSULATED AS PER SPECIFICATION.
2. ALL PIPING AND VALVES OF SIZE 50NB & BELOW SHALL BE PROVIDED AS PER SYSTEM REQUIREMENT
3. ALL PRESSURE GAUGES, PRESSURE SWITCHES, DIFFERENTIAL PRESSURE SWITCHES SHALL BE PROVIDED WITH ISOLATION VALVE / MANIFOLDS AS PER TECHNICAL SPECIFICATION.
4. TEMPERATURE SENSOR (TE) & RELATIVE HUMIDITY SENSOR (RHS) SHALL BE PROVIDED IN EACH AHU ROOM.
5. ALL INSTRUMENT AND TEST POINTS SHALL BE PROVIDED WITH ISOLATING ROOT VALVE
6. MOTORIZED VALVES, IF ANY, SHALL BE PROVIDED WITH SPECTACLE BLIND WITH COUNTER FLANGE FOR LINE ISOLATION.
7. ALL EQUIPMENT DRAIN SHALL BE CONNECTED TO NEAREST BUILDING / PLANT ROOM DRAIN.
8. ONE NO. DRY BULB & WET BULB THERMOMETER WITH PSYCHOMETRIC CHART SHALL BE PROVIDED IN EACH AIR CONDITIONED ROOM.
9. ALL VALVES SHALL BE LOCATED AT GRADE / MAN APPROACHABLE HEIGHT. METALLIC STOOL / LADDER TO BE PROVIDED BY AC SUPPLIER FOR ACCESSING VALVES / EQUIPMENTS.
10. NUMBER AND SIZE OF REFRIGERANT LINES BETWEEN INDDOR AND OUTDOOR UNIT OF AIR COOLED DX TYPE AC SHALL BE AS PER MANUFACTURER GA DRAWING.
11. EQUIPMENT / VALVES / INSTRUMENTS / LINE SIZE IN THE REFRIGERANT LINES BETWEEN INDOOR AND OUTDOOR UNIT OF AIR COOLED DX TYPE AC SHALL BE AS PER MANUFACTURER GA DRAWING.
12. INSTRUMENT MARKED WITH "\*" IS PART OF THE EQUIPMENT
13. AIR RELEASE VALVE SHALL BE PROVIDED AS PER SYSTEM REQUIREMENT AT SUITABLE LOCATION.
14. P&ID SHOWS ONLY THE BARE MINIMUM REQUIREMENT OF VALVES AND INSTRUMENTS. ANY INSTRUMENTATION, VALVE AS REQUIRED FOR THE COMPLETION OF THE SYSTEM IN LINE WITH TECHNICAL SPECIFICATION SHALL BE PROVIDED BY BIDDER DURING DETAILED ENGINEERING WITHOUT ANY COMMERCIAL IMPLICATION

CUSTOMER	NTPC		
PACKAGE	HVAC SYSTEM		
PROJECT	2X250 MW NSPCL BHILLAI FGD		
BHARAT HEAVY ELECTRICALS LTD, POWER SECTOR, PROJECT ENGINEERING MANAGEMENT, NOIDA	DATE	BY	CHECK
	DATE	BY	CHECK
TITLE: PROCESS & INSTRUMENTATION DIAGRAM FOR AC SYSTEM AIR COOLED DX TYPE AC FOR FGD CONTROL BUILDING			
NO.	DATE	BY	CHECK
NO.	DATE	BY	CHECK
DRAWING No. PE-DG-468-(571-13000A)-A101		SHEET 01 OF 01	





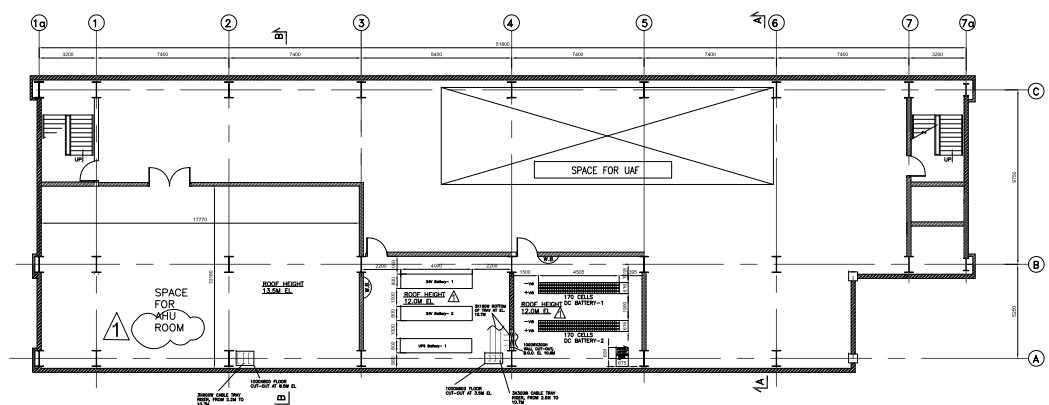

PLAN AT 8.5M

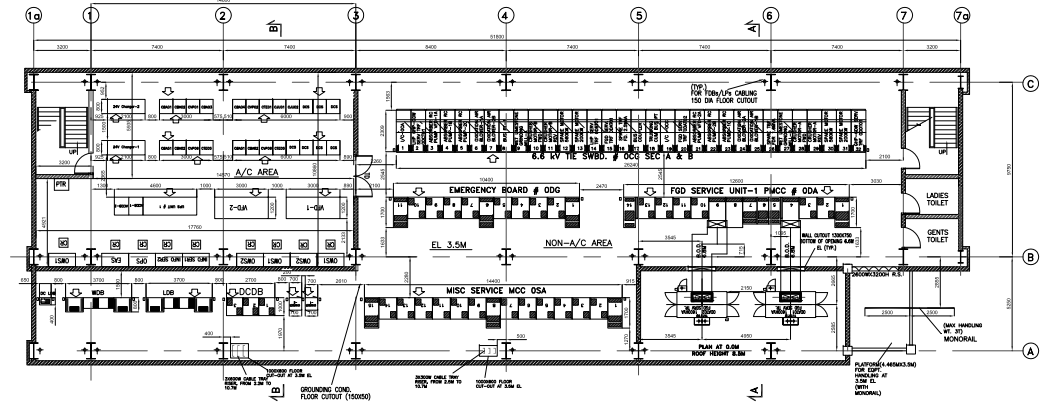

PLAN AT 3.5M

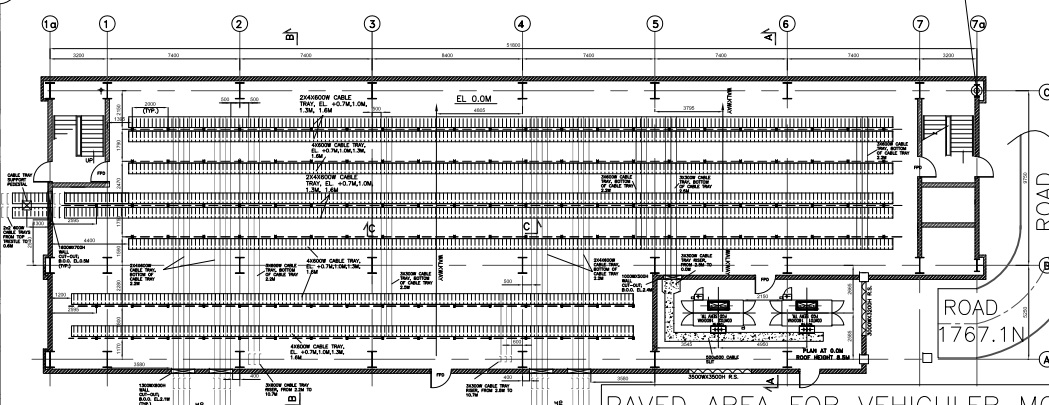

PLAN AT 0.0M

LEGEND

- OPERATING FRONT OF THE PANEL
- BRICK WALL
- CABLE TRAYS
- DOUBLE LEAF DOOR
- SINGLE LEAF DOOR
- DOUBLE LEAF FIRE PROOF DOOR
- DOUBLE LEAF DOOR WITH TRANSOM ARRANGEMENT

REFERENCE DRAWINGS :

S. NO.	TITLE	DRAWING NO.	SOURCE AGENCY
1.	LAYOUT OF FGD SYSTEM	9993-109-PVM-F-020	BHEL-RANIPET
2.	ELECTRICAL SINGLE LINE DIAGRAM	9993-109-PVE-W-302	PEM/ ELECT
3.	OGA OF 2500KVA TRANSFORMER	XXXXXXXXXX	BHEL/ JHANSI
4.	FOUNDATION PLAN OF 2500KVA TRANSFORMER	XXXXXXXXXX	BHEL/ JHANSI
5.	OGA OF 1600KVA TRANSFORMER	XXXXXXXXXX	BHEL/ JHANSI
6.	FOUNDATION PLAN OF 1600KVA TRANSFORMER	XXXXXXXXXX	BHEL/ JHANSI
7.	LAYOUT & KEY DIAGRAM FOR 6.6KV OCG BOARD	9993-109-PVM-B-329	BHEL/ BHOPAL
8.	LAYOUT & KEY DIAGRAM FOR FGD PMCC ODA	XXXXXXXXXX	BHEL/ EPD
9.	LAYOUT & KEY DIAGRAM FOR EMERGENCY MCC OGD	XXXXXXXXXX	BHEL/ EPD
10.	LAYOUT & KEY DIAGRAM FOR MISC SERV MCC OSA	XXXXXXXXXX	BHEL/ EPD
11.	GA OF DC LDB	XXXXXXXXXX	XXXXXX
12.	GA OF 50KVA AC LDB	XXXXXXXXXX	XXXXXX
13.	GA OF 100KVA AC LDB	XXXXXXXXXX	XXXXXX
14.	GA OF 220V CHARGER	XXXXXXXXXX	XXXXXX
15.	GA OF 220V BATTERY	XXXXXXXXXX	XXXXXX
16.	GA OF 24V BATTERY	XXXXXXXXXX	XXXXXX

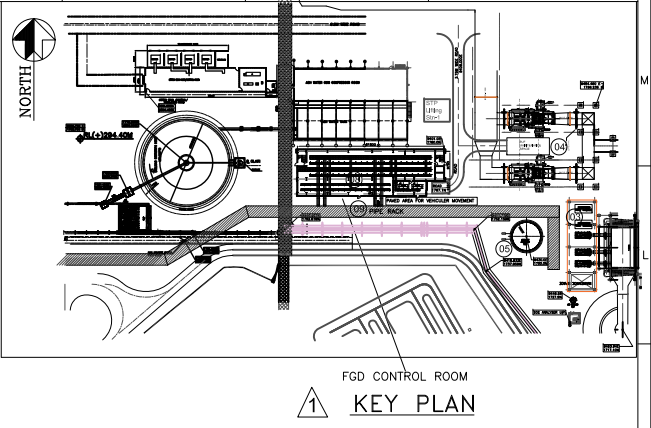

KEY PLAN

NOTES :

1. ALL ELEVATIONS ARE WITH RESPECT TO MAIN POWER HOUSE BUILDING GROUND FLOOR LEVEL AS EL.(±)0.00 M. WHICH CORRESPONDS TO R.L. +294.4M.
2. ALL DIMENSIONS ARE IN MM AND ELEVATIONS IN METRES UNLESS STATED OTHERWISE.
3. THE LT PANEL DIMENSIONS INDICATED IN DRAWING ARE TENTATIVE AND ARE SHOWN FOR DEVELOPING CONCEPTUAL LAYOUT.
4. THIS DRAWING IS TO BE REFERRED FOR DETAILS OF ELECTRICAL EQUIPMENT AND CABLING LAYOUT ONLY. LAYOUT SHOWN FOR FACILITIES SUCH AS AC & VENTILATION SYSTEM IS INDICATIVE & FOR INTERFACE PURPOSE. FOR EXACT LAYOUT OF OTHER SYSTEMS, RELEVANT DISCIPLINE DRAWINGS SHALL BE REFERRED.
5. ALL AREAS SHOWN IN THIS DRAWING ARE NON A/C UNLESS STATED OTHERWISE.
6. BOTTOM MOST/OUTERMOST TRAY MARKED WITH \* \* \* OF SHALL BE PERFORATED TYPE.
7. BOTH SWITCHGEAR ROOM & CABLE VAULT ROOM SHALL BE VENTILATED.
8. DOORS IN CABLE VAULT SHALL BE FIRE PROOF.
9. SUITABLE GRADE FLOOR MATTING FOR PREVENTION OF SHOCKS SHALL BE PROVIDED IN THE SWITCHGEAR ROOM.

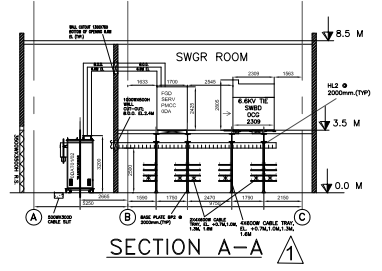

SECTION A-A

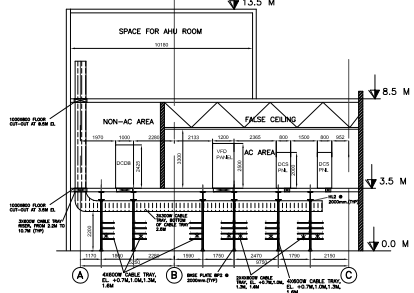

SECTION B-B

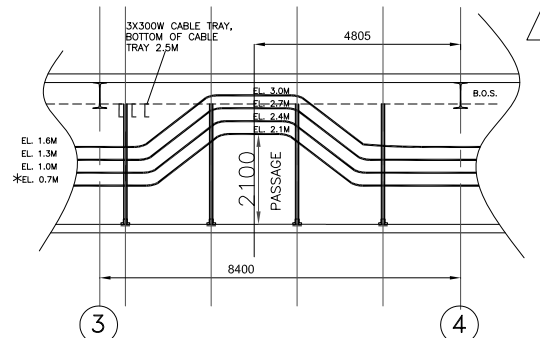

SECTION C-C

TABLE-1 : AUXILIARY SERVICE TRANSFORMERS

S.NO.	TRANSFORMER ID	SERVICE	RATING/ PARAMETERS	LOCATION OF TRANSFORMER
1	ODAT01, ODAT02	FGD SERVICE TRANSFORMER	1.6 MVA, 6.6/0.433 KV, AN, Dyn1, 2+12%, OCTC, +/- 5% IN STEPS OF 2.5%	FGD CONTROL ROOM
2	ODBT01	LHP SERVICE TRANSFORMER	2.5 MVA, 6.6/0.433 KV, AN, Dyn1, 2+12%, OCTC, +/- 5% IN STEPS OF 2.5%	LHP/GHP-GDW SWGR ROOM
3	ODCT01	LHP-GHP-GDW SERVICE TRANSFORMER	2.5 MVA, 6.6/0.433 KV, AN, Dyn1, 2+12%, OCTC, +/- 5% IN STEPS OF 2.5%	LHP/GHP-GDW SWGR ROOM
4	ODDT01	GHP-GDW SERV. TRANSFORMER	2.5 MVA, 6.6/0.433 KV, AN, Dyn1, 2+12%, OCTC, +/- 5% IN STEPS OF 2.5%	LHP/GHP-GDW SWGR ROOM

TABLE-2 : SWITCHBOARDS

S.NO.	SWITCHBOARD ID	SERVICE	RATING/ PARAMETERS	LOCATION OF SWITCHBOARD
1	ODS MECA OGD SER-V	6.6KV TR SWRCHGEAR	6.6KV, 3000 A	FGD CONTROL ROOM
2	ODS	415V FGD SERV U 1 PMCC	415V, 280A	FGD CONTROL ROOM
3	ODS	415V MISC SERV VACC	415 V, 600 A	FGD CONTROL ROOM
4	ODS	415V FGD EMERGENCY MCC	415V	FGD CONTROL ROOM
5	ODS	220V COMMON DCDB	220V	FGD CONTROL ROOM
6	ODS	415V LHP PMCC	4000A	LHP/GHP-GDW SWGR ROOM
7	ODS	415V GHP-GDW AREA PMCC	4000A	LHP/GHP-GDW SWGR ROOM
8	ODS	415V FGD SERV U 2 PMCC	600A	LHP/GHP-GDW SWGR ROOM
9	ODS	415V GDW AREA AC VENT ACDB	400A	LHP/GHP-GDW SWGR ROOM

DETAILS OF PANEL FIXING & CABLE CUTOUT FOR 6.6KV SWGR

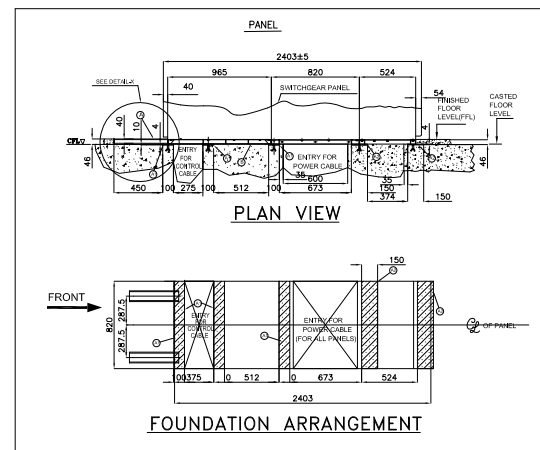

FOUNDATION ARRANGEMENT

PANEL SUPPORTING STRUCTURE AT EVERY SHIPPING SECTION TO BE SUPPLIED BY CIVIL

LT SWGR PANEL WIDTH

CUTOUT

DETAILS OF PANEL FIXING & CABLE CUTOUT FOR 415V LT SWGR

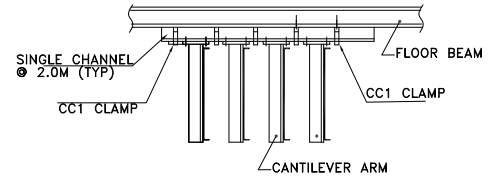

(TYPICAL FIXING DETAILS FOR FIXING OF CROSS TRAYS)

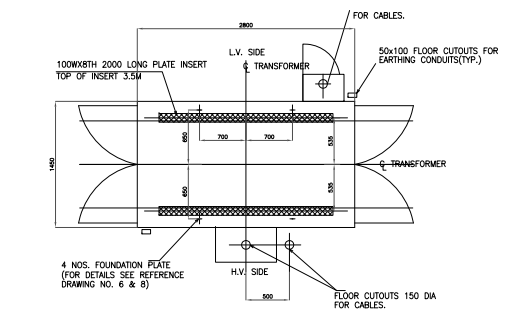

TYPICAL FOUNDATION PLAN FOR DRY TYPE TRANSFORMER

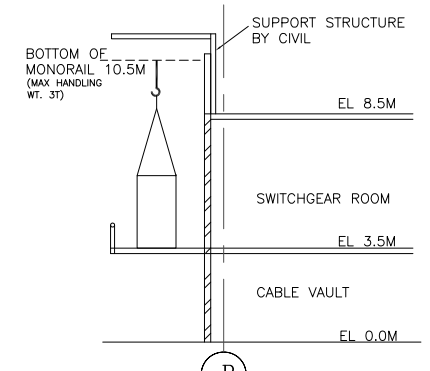

TYPICAL ARRANGEMENT OF EQUIPMENT HANDLING AT EL. 3.5M WITH MONORAIL

NTPC DRAWING No. 9993-109-PVE-B-030

JOB NO. 468  
STATUS CONTRACT  
DISTRIBUTION  
TO: [ ]  
NO. OF: [ ]  
REV. DATE: 01 28.05.2020  
ALTD: [ ]  
CHD: [ ]  
APPD: [ ]

NATIONAL THERMAL POWER CORPORATION LTD.  
2 X 250MW BHILAI THERMAL POWER PLANT  
FGD SYSTEM

BHARAT HEAVY ELECTRICALS LTD  
POWER SECTOR  
PROJECT ENGINEERING MANAGEMENT  
NOIDA

DEPT CODE	NAME	SIGN	DATE
DRN	Srm/AnA	-SD-	-SD-
DESN	Srm/AnA	-SD-	-SD-
CHD	ADA	-SD-	-SD-
APPD	SL	-SD-	-SD-

TITLE: LAYOUT FOR ELECTRICAL & CONTROL ROOM BUILDING  
DEPT. SCALE: [ ]  
SIGN: [ ]  
DATE: [ ]  
DRAWING NO. PE-DG-468-100-E001  
SHEET 1 OF 1 REV. 01

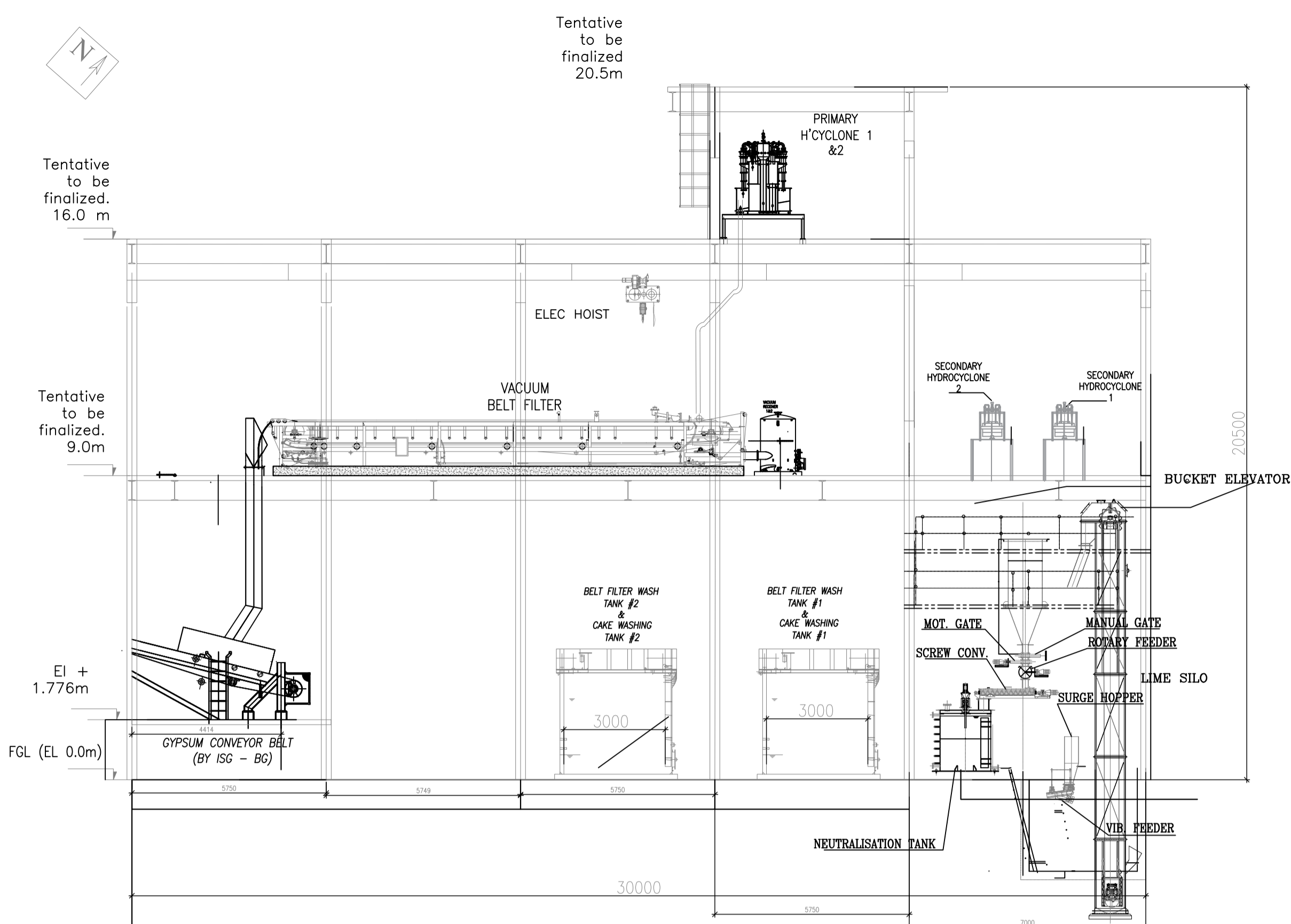

SECTION - BB

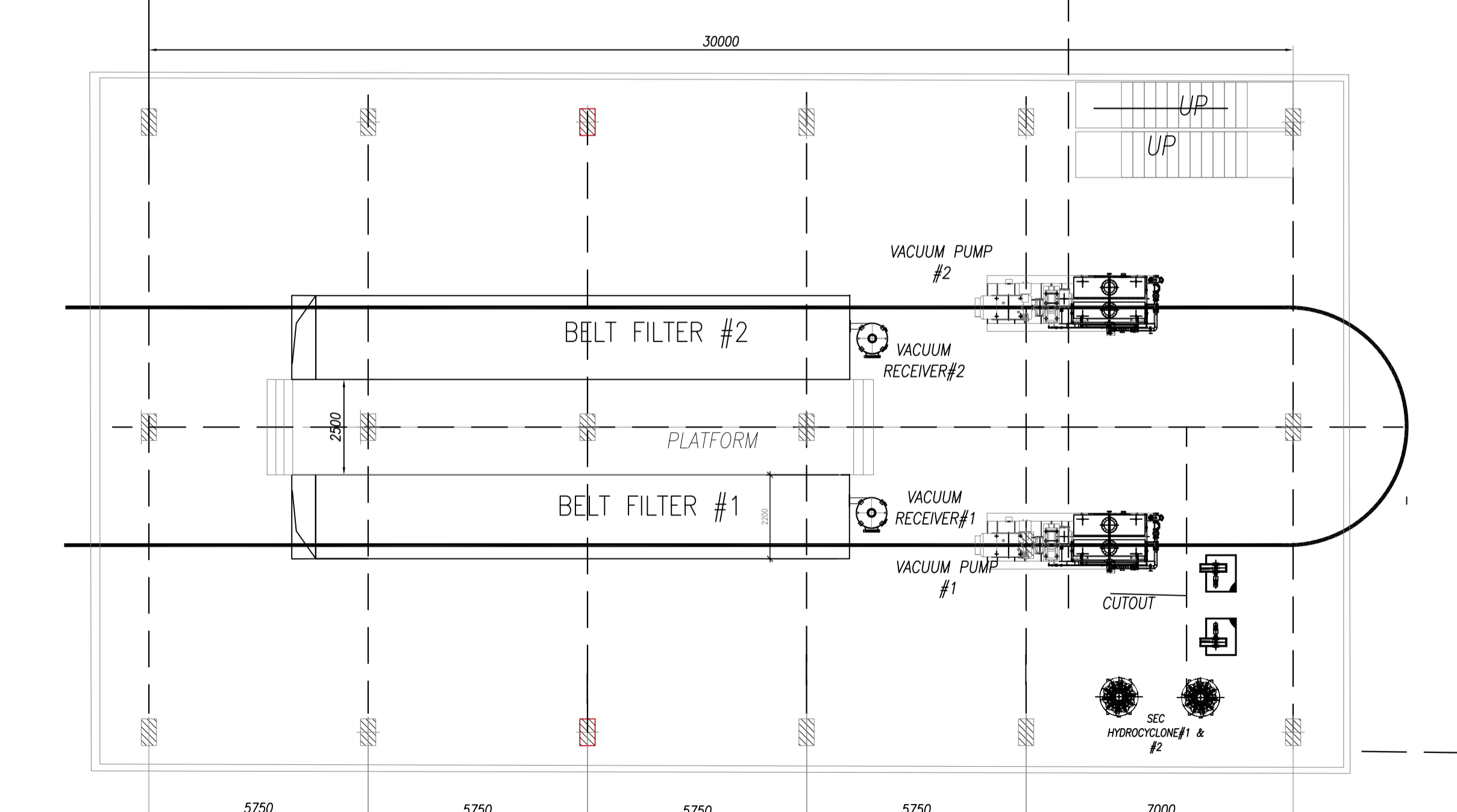

PLAN @ EL (+) 9.00M

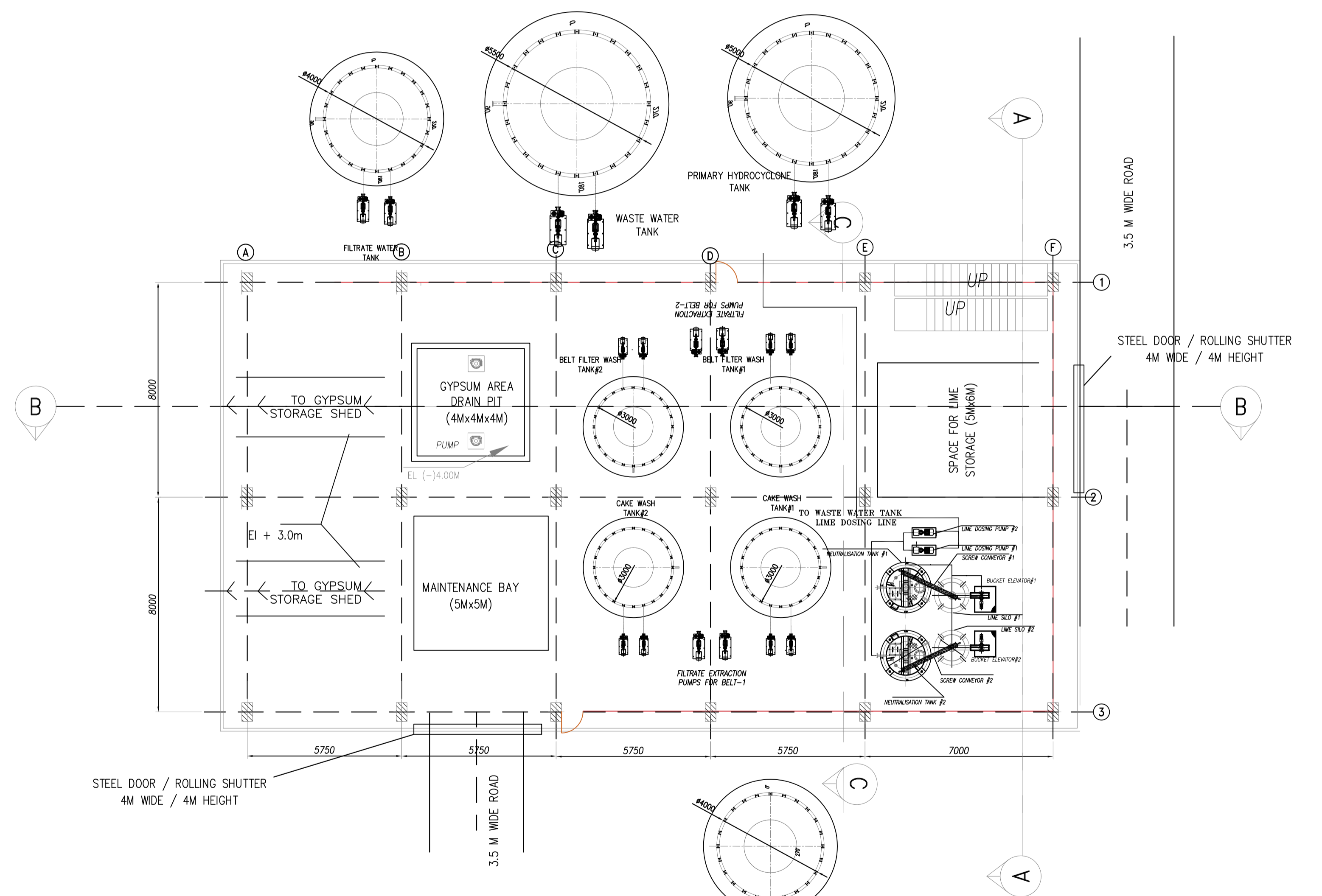

PLAN @ EL(±)0.00M

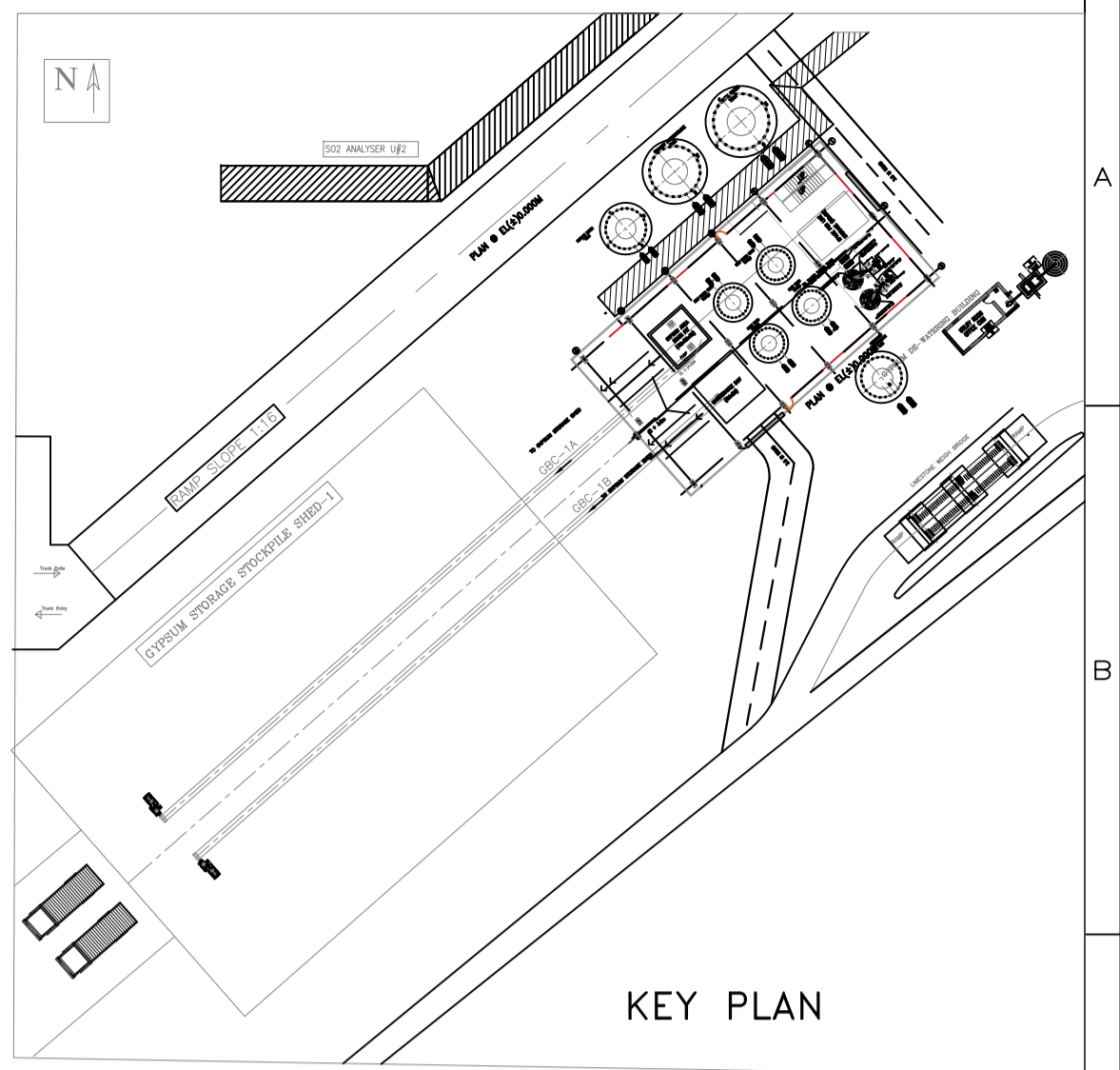

KEY PLAN

OWNER/PROJECT:				NSPCL BHILAI EXPANSION POWER PROJECT NSPCL BHILAI (2X250MW) - FGD SYSTEM PACKAGE			
PACKAGE VENDOR:		NAME	SIGN	DATE			
		DRN.	SA/RG	22-05-20			
		CHD.	RR/PK	22-05-20			
		APPD.	GB	22-05-20			
tkil DWG. NO. :				tkil REV. NO. :			
TITLE : GA OF GDW BUILDING							
STATUS OF DRG.: FOR APPROVAL				NTPC DWG. NO. : 9993-109-PVM-B-047			
SCALE : BHEL JOB NO. :		BHEL DWG. NO. :		SHEET NO. :		REV. :	
NTS		PE-DG-468-571-A001		01 OF 02		RO	

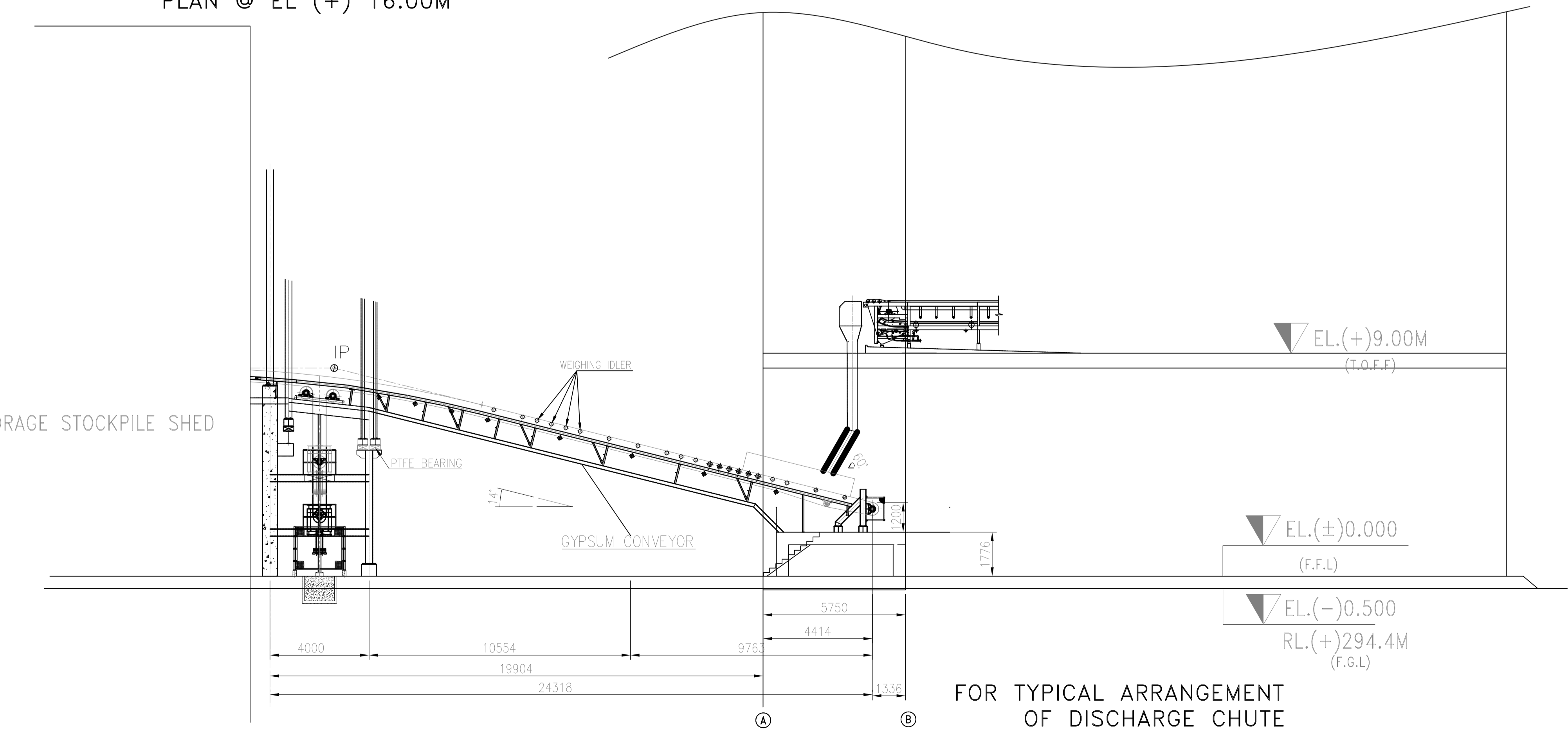
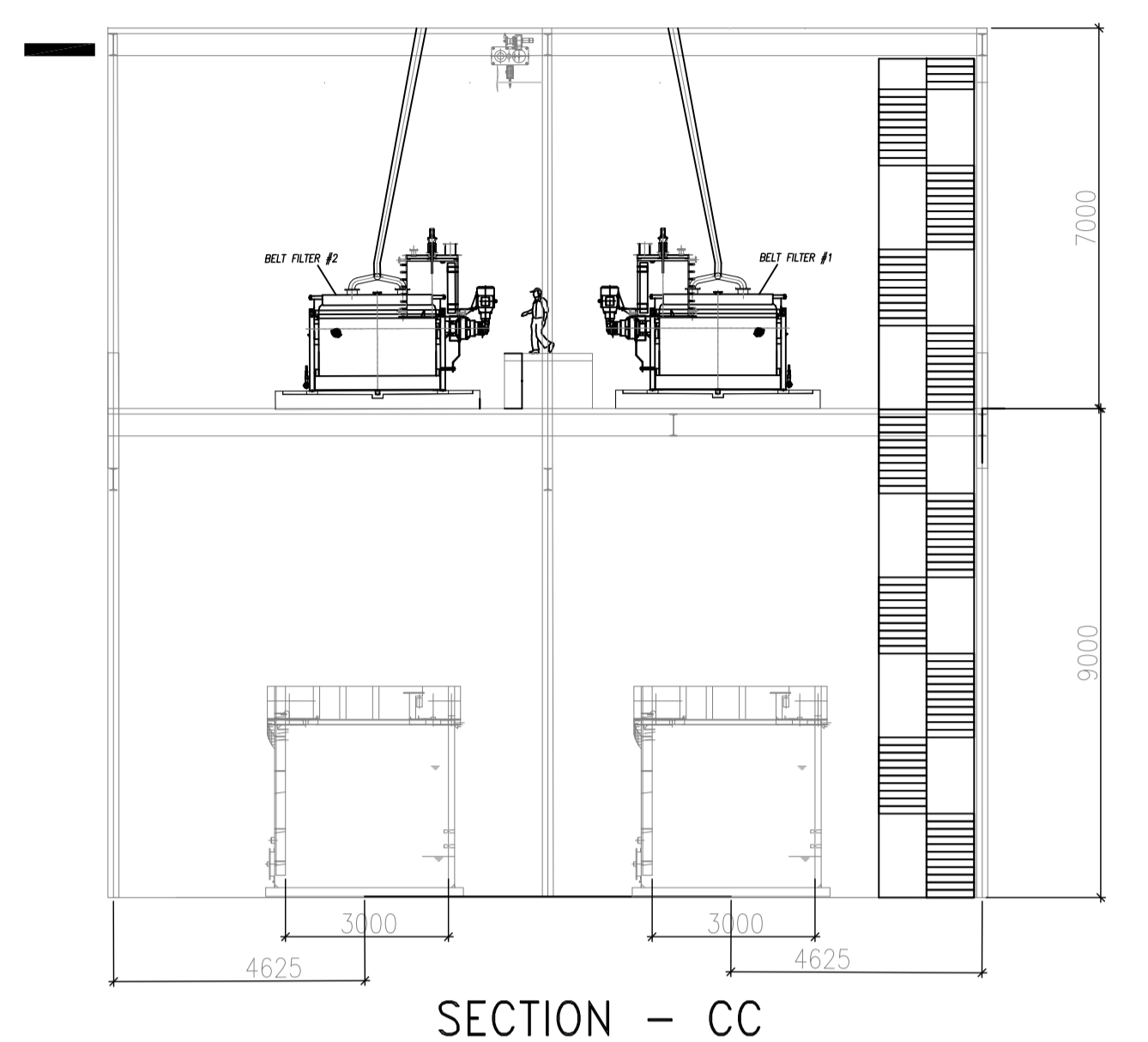
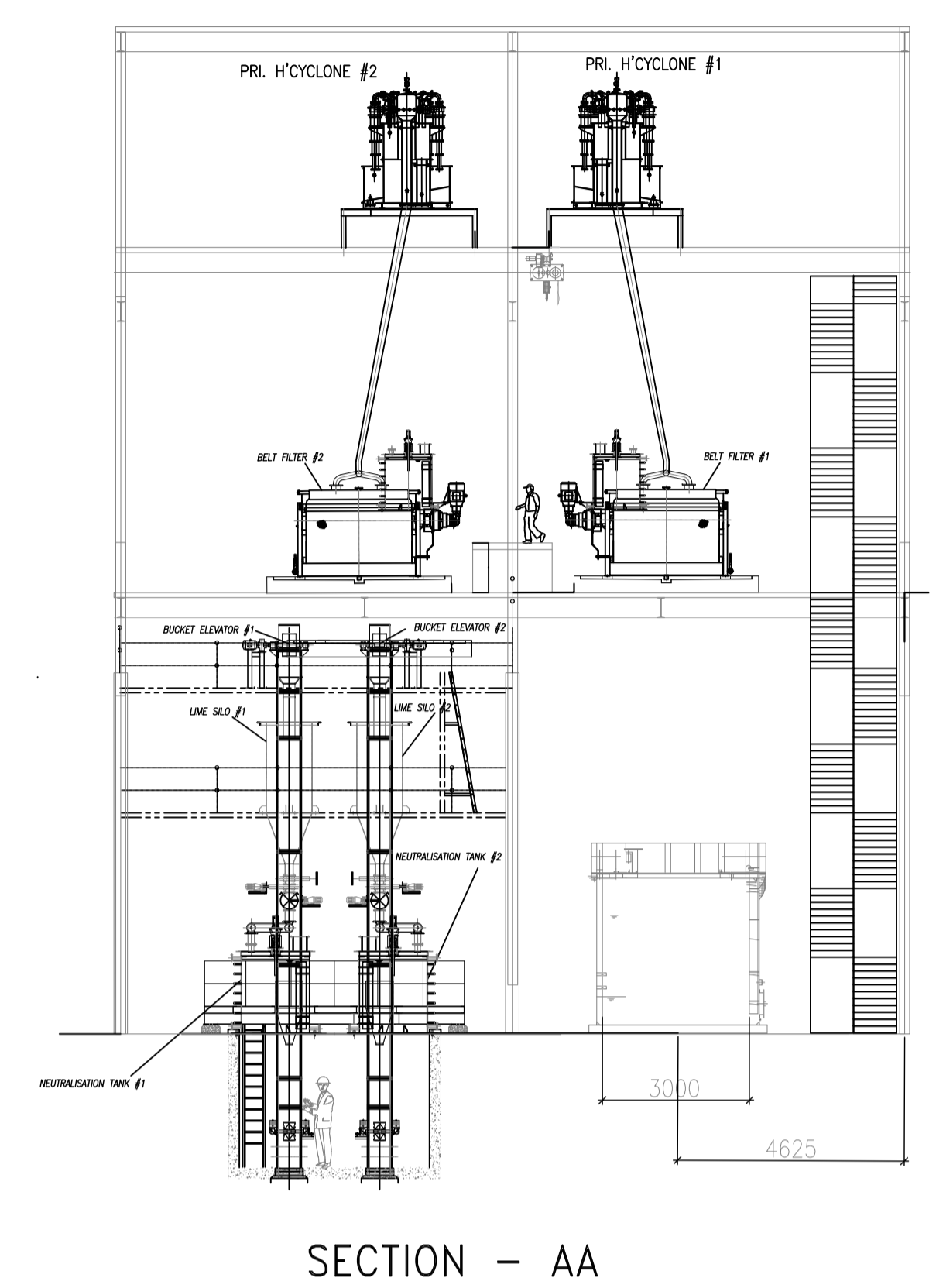
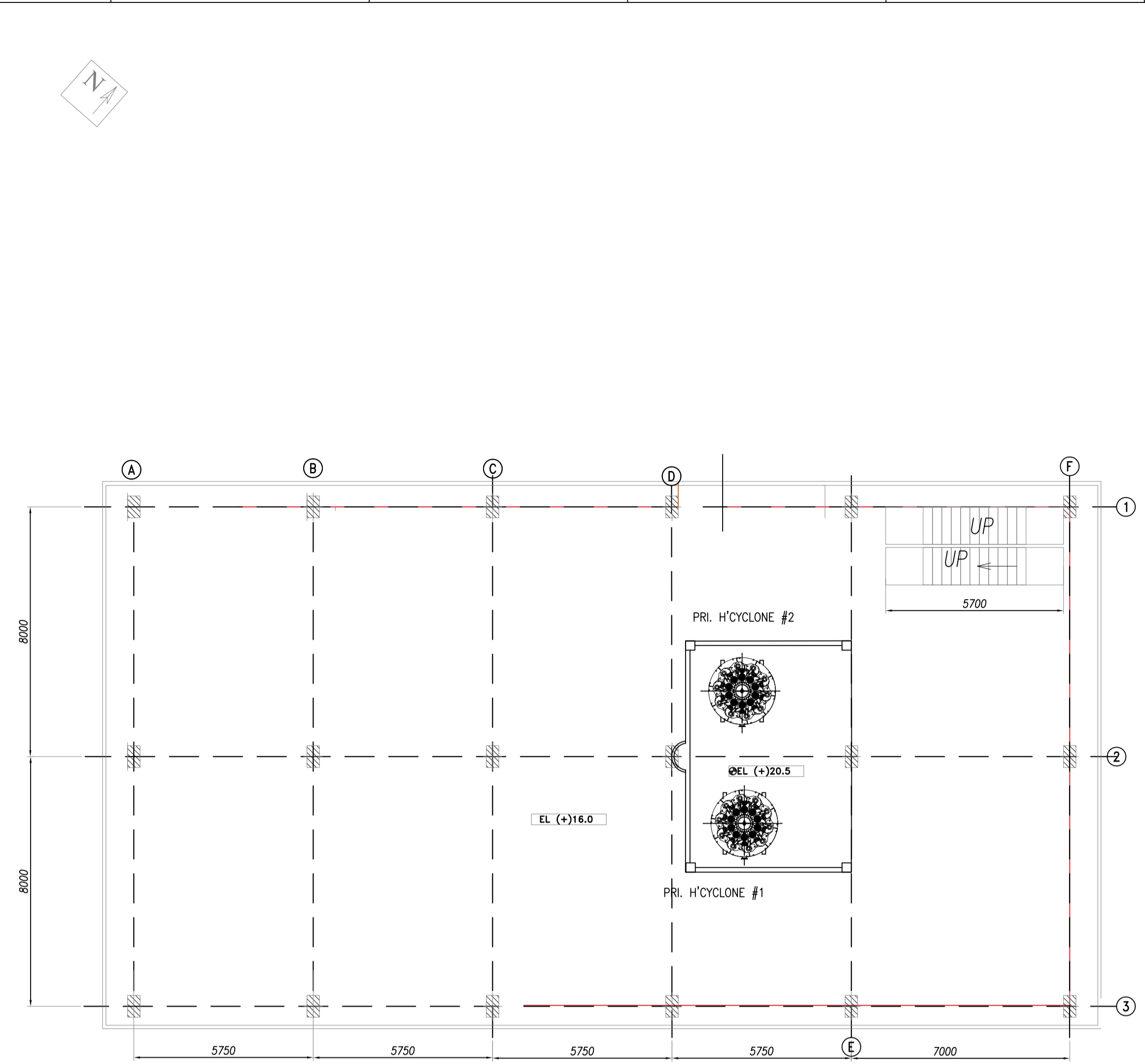

FOR TYPICAL ARRANGEMENT OF DISCHARGE CHUTE

- Notes:
- All Dimensions are in millimeters and elevations in meters.
  - EL 0.0m corresponds to RL +294.9M
  - Drawing layout Civil drawing shall be prepared based on layout on finalized with vendor.
  - Seal pit dimension (\*) shall be furnished by the bidder.
  - Bidder to confirm the capacity and layout for handling equipments.
  - This layout drawing is conceptual layout of GDW building. For scope bidder to refer technical Specification location of equipment may slightly vary as per requirement of the system and Layout shall be finalised with supplier during detailed engineering.

OWNER/PROJECT:	NSPCL BHILAI EXPANSION POWER PROJECT NSPCL BHILAI (2X250MW) - FGD SYSTEM PACKAGE		
PACKAGE VENDOR:	NAME	SIGN	DATE
	DRN.	SA/RG	22-05-20
	CHD.	RR/PK	22-05-20
	APPD.	GB	22-05-20
tkil DWG. NO. :	tkil REV. NO.:		
TITLE : GA OF GDW BUILDING			
STATUS OF DRG.:	FOR APPROVAL	NTPC DWG. NO.:	9993-109-PVM-B-047
SCALE :	BHEL JOB NO. :	BHEL DWG. NO. :	SHEET NO. : 02 OF 02
NTS	PE-DG-468-571-A001		REV. RO